



CONCESSION AGREEMENT

For

Four laning of NH-163 from Hyderabad (ORR Appa Junction) (Design Km 14.000/Existing Km 14.000) to Manneguda (Design Km 60.405/Existing Km 59.500) (Design Length = 46.405 Km) in the State of Telangana under NH(O) on Hybrid Annuity Mode

BETWEEN

NATIONAL HIGHWAYS AUTHORITY OF INDIA

G-5 & 6, Sector 10, Dwarka, New Delhi-110075

AND

M/s MEIL APPA JUNCTION MANNEGUDA ROADWAYS PRIVATE LIMITED

Unit 22, Technocrat Industrial Estate, Bala Nagär, Hyderabad, Rangareddi, Telangana, India-500033

Volume-I:

Concession Agreement (incl. Schedules)

CONTENTS

S. NO.	DESCRIPTION	PAGE NO.
1.	VOLUME I - Concession Agreement & its Schedules	01-297
2.	VOLUME II - Annexures (RFP, Corrigendum, Amendments, Documents submitted by the Selected Bidder & SPV etc.) - Technical Bid Submitted by the Bidder (Project Experience Certificates, Undertakings, Power of Attorney, Bid Security, Tender Fees etc.)	01-270 271-412
3.	VOLUME III - Drawings	01-100



CONCESSION AGREEMENT

For

Four laning of NH-163 from Hyderabad (ORR Appa Junction) (Design Km 14.000/Existing Km 14.000) to Manneguda (Design Km 60.405/Existing Km 59.500) (Design Length = 46.405 Km) in the State of Telangana under NH(O) on Hybrid Annuity Mode

BETWEEN

NATIONAL HIGHWAYS AUTHORITY OF INDIA

G-5 & 6, Sector 10, Dwarka, New Delhi-110075

AND

M/s MEIL APPA JUNCTION MANNEGUDA ROADWAYS PRIVATE LIMITED

Unit 22, Technocrat Industrial Estate, Bala Nagar, Hyderabad, Rangareddi, Telangana, India-500033

Consists:

1. **Volume-I: Concession Agreement (incl. Schedules)**
2. **Volume-II: Annexures to Concession Agreement & Technical Bid submitted by the Selected Bidder**
3. **Volume-III: Drawings**

Contents		
PART I		
Concession Agreement		01
1 Definitions and Interpretation		01
1.1	Definitions	05
1.2	Interpretation	05
1.3	Measurements and arithmetic conventions	07
1.4	Priority of agreements, clauses and schedules	07
PART II		09
The Concession		09
2 Scope of the Project		10
2.1	Scope of the Project	10
3 Grant of Concession		11
3.1	The Concession	11
4 Conditions Precedent		12
4.1	Conditions Precedent	12
4.2	Damages for delay by the Authority	13
4.3	Damages for delay by the Concessionaire	13
4.4	Commencement of Concession Period	14
4.5	Deemed termination upon delay	14
5 Obligations of the Concessionaire		15
5.1	Obligations of the Concessionaire	15
5.2	Obligations relating to Project Agreements	16
5.3	Obligations relating to Change in Ownership	17
5.4	Obligations relating to employment of foreign nationals	18
5.5	Obligations relating to employment of trained personnel	18
5.6	Facilities for differently abled and elderly persons	19
5.7	Branding of Project	19
5.8	Sole purpose of the Concessionaire	19



PUBLIC PRIVATE PARTNERSHIP IN HYBRID ANNUITY PROJECTS

5.9 Obligations relating to Local Content	19
6 Obligations of the Authority	
6.1 Obligations of the Authority	20
6.2 Maintenance obligations prior to Appointed Date	20
6.3 Obligations relating to refinancing	21
7 Representations and Warranties	23
7.1 Representations and warranties of the Concessionaire	23
7.2 Representations and warranties of the Authority	25
7.3 Disclosure	25
8 Disclaimer	
8.1 Disclaimer	26
	26
PART III	27
Development and Operations	27
9 Performance Security	
9.1 Performance Security	28
9.2 Appropriation of Performance Security	28
9.3 Release of Performance Security	28
9.4 Deleted	28
9.5 Deleted	29
9.6 Reference to Performance Security	29
9.7 Additional Performance Security	29
9.8 Appropriation and Release of Additional Performance Security	29
10 Right of Way	30
10.1 The Site	30
10.2 Licences, Access and Right of Way	30
10.3 Procurement of the Site	31
10.4 Site to be free from Encumbrances	33
10.5 Protection of Site from Encumbrances	33
10.6 Special/temporary right of way	33
10.7 Access to the Authority and Independent Engineer	33
10.8 Geological and archaeological finds	34



PUBLIC PRIVATE PARTNERSHIP IN HYBRID ANNUITY PROJECTS

10.9 Land for wayside amenities	34
11 Utilities, Associated Roads and Trees	35
11.1 Existing utilities and roads	35
11.2 Shifting of obstructing utilities	35
11.3 New utilities and roads	36
11.4 Felling of Trees	36
12 Construction of the Project	37
12.1 Obligations prior to commencement of construction	37
12.2 Drawings	37
12.3 Construction of the Project	38
12.4 Maintenance during Construction Period	39
12.5 Deleted	39
13 Monitoring of Construction	40
13.1 Monthly progress reports	40
13.2 Inspection	40
13.3 Tests	40
13.4 Delays during construction	41
13.5 Suspension of unsafe Construction Works	41
13.6 Video recording	42
14 Completion Certificate	44
14.1 Tests	44
14.2 Completion Certificate	44
14.3 Provisional Certificate	44
14.4 Completion of Punch List items	45
14.5 Withholding of Provisional or Completion Certificate	45
14.6 Rescheduling of Tests	46
15 Entry into Commercial Service	47
15.1 Commercial Operation Date (COD)	47
15.2 Damages for delay	47
16 Change of Scope	48
16.1 Change of Scope	48



PUBLIC PRIVATE PARTNERSHIP IN HYBRID ANNUITY PROJECTS

16.2	Procedure for Change of Scope	48
16.3	Payment for Change of Scope	49
16.4	Restrictions on certain works	49
16.5	Power of the Authority to undertake works	50
16.6	Reduction in Scope of the Project	50
16.7	Effect of Change in Scope on the O&M Costs.	51
17 Operation and Maintenance		52
17.1	O&M obligations of the Concessionaire	52
17.2	Maintenance Requirements	53
17.3	Maintenance Manual	53
17.4	Maintenance Program	53
17.5	Safety, breakdowns and accidents	54
17.6	De-commissioning due to Emergency	54
17.7	Project closure	54
17.8	Damages for breach of maintenance obligations	55
17.9	Authority's right to take remedial measures	55
17.10	Overriding powers of the Authority	56
17.11	Restoration of loss or damage to Project	56
17.12	Modifications to the Project	57
17.13	Excuse from performance of obligations	57
17.14	Deleted	57
17.15	Installation and operation of CCTV	57
17.16	Advertising on the site	57
18 Safety Requirements		58
18.1	Safety Requirements	58
18.2	Expenditure on Safety Requirements	58
19 Monitoring of Operation and Maintenance		59
19.1	Monthly status reports	59
19.2	Inspection	59
19.3	Tests	59
19.4	Remedial measures	59



PUBLIC PRIVATE PARTNERSHIP IN HYBRID ANNUITY PROJECTS

19.5	Reports of unusual occurrence	60
20 Regulation and Management		61
20.1	Traffic regulation by the Concessionaire	61
20.2	Police assistance	61
20.3	Buildings for Traffic Aid Posts	61
20.4	Medical Aid Posts	61
20.5	Buildings for Medical Aid Posts	61
20.6	Computer systems and network	61
20.7	Recurring expenditure on Police assistance	62
20.8	Recurring expenditure on Medical Aid Post	62
21 Independent Engineer		63
21.1	Appointment of Independent Engineer	63
21.2	Duties and functions	63
21.3	Remuneration	63
21.4	Termination of appointment	63
21.5	Authorized signatories	64
21.6	Dispute resolution	64
21.7	Interim arrangement	64
PART IV		65
Financial Covenants		65
22 Financial Close		66
22.1	Financial Close	66
22.2	Termination due to failure to achieve Financial Close	66
23 Payment of Bid Project Cost		68
23.1	Bid Project Cost	68
23.2	Adjust Bid Project Cost	68
23.3	Payment of Bid Project Cost	69
23.4	Payment during Construction Period	69
23.5	Bonus on early completion	69



PUBLIC PRIVATE PARTNERSHIP IN HYBRID ANNUITY PROJECTS

23.6 Annuity Payments during Operation Period	70
23.7 O&M Payments	72
23.8 Mobilization advance	73
23.9 Treatment of incomplete works	73
24 Article 24	75
Deleted	75
25 Escrow Account	76
25.1 Escrow Account	76
25.2 Deposits into Escrow Account	76
25.3 Withdrawals during Concession Period	76
25.4 Withdrawals upon Termination	77
26 Insurance	78
26.1 Insurance during Concession Period	78
26.2 Insurance Cover	78
26.3 Notices to the Authority	78
26.4 Evidence of insurance Cover	79
26.5 Remedy for failure to insure	79
26.6 Waiver for subrogation	79
26.7 Concessionaire's waiver	79
26.8 Application of insurance proceeds	79
26.9 Compliance with conditions of insurance policies	80
27 Account And Audit	81
27.1 Audited Accounts	81
27.2 Appointment of Auditors	81
27.3 Certification of claims by Statutory Auditors	82
27.4 Set-off	82
27.5 Dispute resolution	82
Part-V	83
Force Majeure and Termination	83
28 Force Majeure	84
28.1 Force Majeure	84



PUBLIC PRIVATE PARTNERSHIP IN HYBRID ANNUITY PROJECTS

28.2 Non-Political Event	84
28.3 Indirect Political Event	85
28.4 Political Event	85
28.5 Duty to report Force Majeure Event	86
28.6 Effect of Force Majeure Event on the Concession	86
28.7 Allocation of costs arising out of Force Majeure	87
28.8 Termination Notice for Force Majeure Event	87
28.9 Termination Payment for Force Majeure Event	88
28.10 Dispute resolution	89
28.11 Excuse from performance of obligations	90
28.12 Deleted	90
29 Compensation for Breach of Agreement	91
29.1 Compensation for default by the Concessionaire	91
29.2 Compensation for default by the Authority	91
29.3 Deleted	91
29.4 Mitigation of costs and damage	91
30 Suspension Of Concessionaire's Rights	92
30.1 Suspension upon Concessionaire Default	92
30.2 Authority to act on behalf of Concessionaire	92
30.3 Revocation of Suspension	92
30.4 Substitution of Concessionaire	93
30.5 Termination	93
31 Termination	94
31.1 Termination for Concessionaire Default	94
31.2 Termination for Authority Default	96
31.3 Termination Payment	97
31.4 Certain limitations on Termination Payment	99
31.5 Other rights and obligations of the Authority	99
31.6 Survival of rights	100
32 Divestment of Rights And Interest	101
32.1 Divestment Requirements	101



PUBLIC PRIVATE PARTNERSHIP IN HYBRID ANNUITY PROJECTS

32.2 Inspection and cure	102
32.3 Cooperation and assistance on transfer of Project	102
32.4 Vesting Certificate	102
32.5 Divestment costs etc.	103
33 Defects Liability after Termination	104
33.1 Liability for defects after Termination	104
33.2 Retention in Escrow Account	104
Part VI	105
Other Provisions	105
34 Assignment and Charges	106
34.1 Restrictions on assignment and charges	106
34.2 Permitted assignment and charges	106
34.3 Substitution Agreement	106
34.4 Assignment by the Authority	107
35 Change In Law	108
35.1 Increase in Costs	108
35.2 Reduction in costs	108
35.3 Protection of NPV	109
35.4 Restriction on cash compensation	109
35.5 Deleted	109
36 Liability And Indemnity	110
36.1 General indemnity	110
36.2 Indemnity by the Concessionaire	110
36.3 Notice and contest of claims	111
36.4 Defense of claims	111
36.5 No Consequential claims	112
36.6 Survival on Termination	112
37 Rights and Title over The Site	113
37.1 Licensee rights	113
37.2 Access rights of the Authority and others	113
37.3 Property taxes	113



PUBLIC PRIVATE PARTNERSHIP IN HYBRID ANNUITY PROJECTS

37.4 Restriction on sub-letting	113
38 Dispute Resolution	114
38.1 Dispute resolution	114
38.2 Conciliation	114
38.3 Arbitration	114
38.4 Adjudication by a Regulatory Authority, Tribunal or Commission	115
39 Disclosure	116
39.1 Disclosure of Specified Documents	116
39.2 Disclosure of Documents relating to Safety	116
39.3 Withholding of Disclosure of Protected Documents	116
40 Redressal Of Public Grievances	117
40.1 Complaints Register	117
40.2 Redressal of Complaints	117
41 Miscellaneous	118
41.1 Governing law and jurisdiction	118
41.2 Waiver of immunity	118
41.3 Depreciation	118
41.4 Delayed payments	118
41.5 Waiver	119
41.6 Liability for review of Documents and Drawings	119
41.7 Exclusion of implied warranties etc.	119
41.8 Survival	119
41.9 Entire Agreement	120
41.10 Severability	120
41.11 No partnership	120
41.12 Third parties	120
41.13 Successors and assigns	121
41.14 Notices	121
41.15 Language	121
41.16 Counterparts	122
41.17 State Support Agreement	122



PUBLIC PRIVATE PARTNERSHIP IN HYBRID ANNUITY PROJECTS

42 Definitions	123
42.1 Definitions	123
Schedules	138
A Site of the Project	139
1 The Site	139
Annex-I: Site for Project	140
B Development of the Project	168
1 Development of the Project	168
2 Four-Laning	168
Annex-I: Description of Project	169
C Project Facilities	195
1 Project Facilities	195
Annex-I: Project Facilities	196
D Specifications and Standards	207
1 Specifications and Standards for the Project	207
Annex-I: Specifications and Standards for the project	208
E Applicable Permits	217
1 Applicable Permits	217
F Performance Security	218
G Project Completion Schedule	226
1 Project Completion Schedule	226
2 Project Milestone-I	226
3 Project Milestone-II	226
4 Project Milestone-III	226
5 Scheduled Completion Date	227
6 Extension of Period	227
H Drawings	238
1 Drawings	238
2 Additional drawings	238
Annex-I: List of Drawings	239



PUBLIC PRIVATE PARTNERSHIP IN HYBRID ANNUITY PROJECTS

I Tests	240
1 Schedule for Tests	240
2 Tests	240
3 Agency for conducting Tests	240
4 Completion/Provisional Certificate	241
5 Tests during construction	241
J Completion Certificate	242
1 Completion Certificate	242
2 Provisional Certificate	243
K Maintenance Requirements	244
1 Maintenance Requirements	244
2 Repair/rectification of defects and deficiencies	244
3 Other defects and deficiencies	244
4 Extension of time limit	244
5 Emergency repairs/restoration	245
6 Daily Inspection by the Concessionaire	245
7 Divestment Requirements	245
8 Display of Schedule K	245
Annex-I: Repair/rectification of defects and deficiencies	246
L Safety Requirements	248
1 Guiding Principles	248
2 Obligations of the Concessionaire	248
3 Appointment of Safety Consultant	248
4 Safety measures during Development Period	248
5 Safety measures during Construction Period	249
6 Safety measures during Operation Period	250
7 Costs and expenses	251
M Selection of Independent Engineer	252
1 Selection of Independent Engineer	252
2 Terms of Reference	252
3 Fee and expenses	252



PUBLIC PRIVATE PARTNERSHIP IN HYBRID ANNUITY PROJECTS

	4 Selection every three year	252
	5 Appointment of government entity as Independent Engineer	253
N	Terms of Reference for Independent Engineer	254
	1 Scope	254
	2 Definitions and interpretation	254
	3 Roll and functions of Independent Engineer	254
	4 Development Period	255
	5 Construction Period	255
	6 Operation Period	257
	7 Termination	258
	8 Determination of costs and time	258
	9 Assistance in Dispute resolution	258
	10 Other duties and functions	258
	11 Miscellaneous	258
O	Escrow Agreement	261
	1 Definitions and Interpretation	262
	2 Escrow Account	263
	3 Deposits Into Escrow Account	264
	4 Withdrawals from Escrow Account	265
	5 Obligations of the Escrow Bank	267
	6 Escrow Default	268
	7 Termination of Escrow Agreement	269
	8 Supplementary Escrow Agreement	269
	9 Indemnities	270
	10 Disputes Resolution	270
	11 Miscellaneous Provisions	271
P	Panel of Chartered Accountants	275
	1 Panel of Chartered Accountants	275
	2 Invitation of empanelment	275
	3 Evaluation and selection	275



PUBLIC PRIVATE PARTNERSHIP IN HYBRID ANNUITY PROJECTS

4	Consultation with the Concessionaire	276
5	Mutually agreed panel	276
Q	Vesting Certificate	277
R	Substitution Agreement.	278
1	Definitions and interpretation	279
2	Assignment	280
3	Substitution of the Concessionaire	280
4	Project Agreements	282
5	Termination of Concession Agreement	283
6	Duration of the Agreement	283
7	Indemnity	283
8	Dispute Resolution	284
9	Miscellaneous Provisions	285
S	Procedure for Dispute Resolution Board	289
1	Annexure to Schedule S	291
	Disputes Resolution Board's Rules and Procedures	291
	BOARD MEMBER'S DECLARATION OF ACCEPTANCE	296
	Schedule of expenses and fees payable to the Member (s) of Dispute Resolution Board (DRB)	297



Public Private Partnership

In

Highway Development

CONCESSION AGREEMENT

for

**Four laning of NH-163 from Hyderabad
(ORR Appa Junction) (Design Km
14.000/Existing Km 14.000) to Manneguda
(Design Km 60.405/Existing Km 59.500)
(Design Length = 46.405 Km) in the State of
Telangana under NH(O) on Hybrid Annuity
Mode**

Government of India

April 2022





सत्यमेव जयते

INDIA NON JUDICIAL

Government of National Capital Territory of Delhi

₹200

e-Stamp

Table with 2 columns: Certificate No., Certificate Issued Date, Account Reference, Unique Doc. Reference, Purchased by, Description of Document, Property Description, Consideration Price (Rs.), First Party, Second Party, Stamp Duty Paid By, Stamp Duty Amount(Rs.).

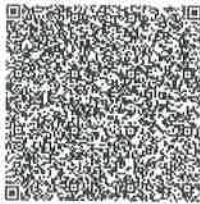

CONCESSION AGREEMENT

THIS AGREEMENT is entered into on this the 09th day of May 2022.

BETWEEN

THE NATIONAL HIGHWAYS AUTHORITY OF INDIA, established under the National Highways Authority of India Act 1988, represented by its Chairman and having its principal offices at G-5 & 6, Sector 10, Dwarka, New Delhi-110075 (hereinafter referred to as the "Authority" which expression shall, unless repugnant to the context or meaning thereof, include its administrators, successors and assigns) of One Part;

AND

MEIL Appa Junction Manneguda Roadways Pvt. Ltd., a Company incorporated under the provisions of the Companies Act, 2013 with CIN U45209TG2022PTC161837 and having its registered office at Unit 22, Technocrat Industrial Estate, Bala Nagar Hyderabad, Rangareddi, Telangana, India - 500 033, (hereinafter referred to as the "Concessionaire" which expression shall, unless repugnant to the context or meaning thereof, include its successors and permitted assigns and substitutes) of the Other Part.

Statutory Alert:

- 1. The authenticity of this Stamp certificate should be verified at 'www.shoilestamp.com' or using e-Stamp Mobile App of State Holding. Any discrepancy in the details on the e-Stamp certificate is available on the website / Mobile App renders it invalid.
2. The onus of checking the legitimacy is on the users of the certificate.
3. In case of any discrepancy please inform the Competent Authority.

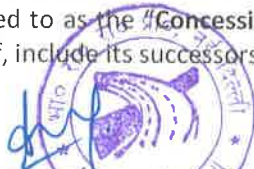

01



WHEREAS:

(A) The Government of India had entrusted to the Authority the development, maintenance and management of National Highway No. 163 including the section from km 14.000 to km. 60.405 (approx. 46.405 km). The Authority had resolved to augment the existing road from km. 14.000 to km. 60.405 (approximately 46.405 km) on the Hyderabad - Manneguda section of National Highway No. 163 (hereinafter called the "NH 163") in the State of Telangana by 4-laning Highway thereof (the "Project") on design, build, operate and transfer (the "DBOT Annuity" or "Hybrid Annuity") basis, which shall be partly financed by the Concessionaire who shall recover its investment and costs through payments to be made by the Authority, in accordance with the terms and conditions to be set forth in a concession agreement to be entered into.

(B) The Authority had adopted a single stage two envelope bidding process and accordingly invited proposals by its Request for Proposals dated 10.09.2021 (the "Request for Proposals" or "RFP") for qualification and short listing of bidders for construction, operation and maintenance of the above referred Project on Hybrid Annuity basis.

(C) The Authority had prescribed the technical and commercial terms and conditions in the RFP, and invited bids comprising technical and financial bids from the bidders for undertaking the Project.

(D) After evaluation of the bids received, the Authority had accepted the financial bid of the Selected Bidder i.e. **M/s Megha Engineering and Infrastructures Ltd.**, and issued its Letter of Award No. NHAI/Tech/AP/NH-163/Hyd-Man/2017-18/155 dated 17.03.2022 (hereinafter called the "LOA") to the selected bidder requiring, inter alia, the execution of this Concession Agreement within 45 (forty five) days of the date of issue thereof.

(E) The Selected Bidder has since promoted and incorporated the Concessionaire as a limited liability company under the Companies Act 2013, and has requested the Authority to accept the Concessionaire as the entity which shall undertake and perform the obligations and exercise the rights of the Selected Bidder under the LOA, including the obligation to enter into this Concession Agreement pursuant to the LOA for undertaking the Project.

(F) By its letter dated 25.04.2022 the Concessionaire has also joined in the said request of the selected bidder to the Authority to accept it as the entity which shall undertake and perform the obligations and exercise the rights of the selected bidder including the obligation to enter into this Concession Agreement pursuant to the LOA. The Concessionaire has further represented to the effect that it has been promoted by the selected bidder for the purposes hereof and has delivered to the Authority a legal opinion with respect to the authority of the Concessionaire to enter into this Concession Agreement and the enforceability of the provisions thereof.

(G) The Authority has agreed to the said request of the selected bidder and the Concessionaire, and has accordingly agreed to enter into this Concession Agreement with the Concessionaire for implementation of the Project on Hybrid Annuity basis, subject to and on the terms and conditions set forth hereinafter.



02





सत्यमेव जयते

INDIA NON JUDICIAL

Government of National Capital Territory of Delhi

e-Stamp

Certificate No.	: IN-DL29751767695439U
Certificate Issued Date	: 09-May-2022 01:43 PM
Account Reference	: IMPACC (IV)/ dl981903/ DELHI/ DL-DLH
Unique Doc. Reference	: SUBIN-DL98190345696668783545U
Purchased by	: MEIL APPA JUNCTION MANNEGUDA ROADWAYS PVT LTD
Description of Document	: Article 5 General Agreement
Property Description	: Not Applicable
Consideration Price (Rs.)	: 0 (Zero)
First Party	: NATIONAL HIGHWAYS AUTHORITY OF INDIA
Second Party	: MEIL APPA JUNCTION MANNEGUDA ROADWAYS PRIVATE LIMITED
Stamp Duty Paid By	: MEIL APPA JUNCTION MANNEGUDA ROADWAYS PRIVATE LIMITED
Stamp Duty Amount(Rs.)	: 200 (Two Hundred only)

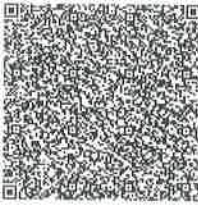

Please write or type below this line

रियायत करार

यह करार आज दिनांक ०९.०५.२०२२ को निम्नलिखित के बीच किया गया।

भारतीय राष्ट्रीय राजमार्ग प्राधिकरण अधिनियम, 1988 के अधीन स्थापित भारतीय राष्ट्रीय राजमार्ग प्राधिकरण जिसके प्रतिनिधि इसके अध्यक्ष हैं और जिसका प्रधान कार्यालय जी-5 एवं 6, सेक्टर-10, द्वारका नई दिल्ली-110075 में हैं (जिसे इसके पश्चात् "प्राधिकरण" कहा जाए और जिसकी अभिव्यक्ति में जब तक इसके संदर्भ अथवा अर्थ से असंगत न हो, इसके प्रशासक, उत्तराधिकारी और समनुदेशिती शामिल होंगे) एक पक्ष;

और

एमईआईएल अप्पा जंक्शन मन्नेगुडा रोडवेज प्राइवेट लिमिटेड, कंपनी अधिनियम, 2013 के उपबंधों के तहत संस्थापित एक कंपनी जिसका सीआईएन यू45209टीजी2022पीटीसी161837 है तथा पंजीकृत कार्यालय यूनिट 22, टेक्नोक्रेट इंडस्ट्रियल एस्टेट बाला नगर हैदराबाद, रंगारेड्डी, तेलंगाना भारत- 500033 में है, (जिसे इसमें इसके पश्चात् "रियायतग्राही" कहा जाए और जिसकी अभिव्यक्ति में जब तक इसके संदर्भ अथवा अर्थ से असंगत न हो, इसके उत्तराधिकारी और अनुमत्य तथा एवजी समनुदेशिती शामिल होंगे) दूसरा पक्ष।

Statutory Alert:

1. The authenticity of this Stamp certificate should be verified at www.shelastamp.com or using e-Stamp Mobile App at any discrepancy in the details on this Certificate available on the website / Mobile App renders it invalid.
2. The duty of checking the legitimacy is on the holder of the certificate.
3. In case of any discrepancy please inform the Competent Authority.



03



यतः

क) भारत सरकार ने 14.000 कि.मी. से 60.405 कि.मी. तक के सेक्शन सहित राष्ट्रीय राजमार्ग 163 (अनुमानित 46.405 कि.मी.) के विकास, रखरखाव और प्रबंधन का कार्य प्राधिकरण को सौंपा था। प्राधिकरण ने तेलंगाना राज्य में राष्ट्रीय राजमार्ग 163 (जिसे इसके पश्चात् "एनएच-163") के हैदराबाद-मन्नेगुडा सेक्शन के 14.000 कि.मी. से 60.405 कि.मी. (अनुमानित 46.405 कि.मी.) की वर्तमान सड़क कहा गया है) के डिजाइन निर्माण, प्रचालन और हस्तांतरण ("डीओबीटी" अथवा "हाइब्रिड वार्षिकी") आधार पर ("परियोजना") 4 लेन का राजमार्ग बनाकर संवर्धन करने का संकल्प लिया था, जिसे किए जाने वाले रियायत करार की निबंधन और शर्तों के अनुसार आंशिक तौर पर रियायतग्राही द्वारा वित्तपोषित किया जाएगा जो कि अपने निवेश और लागत को प्राधिकरण द्वारा किए गए भुगतान के माध्यम से वसूलेगा।

ख) प्राधिकरण ने एक स्तरीय दो लिफाफा बोली प्रक्रिया अपनाई थी और तदनुसार उपर्युक्त परियोजना को हाइब्रिड वार्षिकी आधार पर निर्माण, प्रचालन और रखरखाव के लिए योग्यता और बोलीकर्ताओं के चयन के लिए 10.09.2021 को प्रस्ताव के लिए अनुरोध ("प्रस्ताव के लिए अनुरोध" अथवा "आरएफपी") आमंत्रित किए थे।

ग) प्राधिकरण ने आरएफपी में तकनीकी और वाणिज्यिक निबंधन और शर्तें निर्धारित की थी और परियोजना का कार्य हाथ में लेने के लिए बोलीदाताओं से तकनीकी और वित्तीय बोलियों सहित बोलियां आमंत्रित की थी।

घ) प्राप्त बोलियों के मूल्यांकन के उपरांत, प्राधिकरण ने चयनित बोलीकर्ता मैसर्स मेघा इंजीनियरिंग एंड इनफ्रास्ट्रक्चर लिमिटेड की वित्तीय बोली को स्वीकार किया था और चयनित बोलीकर्ता को ठेका पत्र सं. एनएचएआई/टेक/एपी/एनएच-163/हैद-मन/2017-18/155 दिनांक 17.03.2022 (जिसे इसमें इसके पश्चात् "एलओए" कहा गया है) जारी किया जिसमें अन्य बातों के साथ-साथ इस पत्र के जारी होने के 45 दिन (पैंतालीस दिन) के अन्दर रियायत करार निष्पादित करने की अपेक्षा की गई थी।

ण) चयनित बोलीकर्ता ने कम्पनी अधिनियम 2013 के अधीन रियायतग्राही को सीमित देयता कम्पनी के तौर पर संप्रवर्तित और निगमित कर दिया है और प्राधिकरण को अनुरोध किया है कि रियायतग्राही को निकाय के रूप में स्वीकार किया जाए जो कि एलओए के अनुसरण में परियोजना का कार्य करने के लिए रियायत करार करने के दायित्व सहित एलओए के अंतर्गत चयनित बोलीकर्ता के अधिकारों और दायित्वों का निर्वहन और निष्पादन करेगा।

च) अपने दिनांक 25.04.2022 के पत्र द्वारा रियायतग्राही भी चयनित बोलीकर्ता के उक्त अनुरोध में शामिल हो गया है कि उसे संस्था के रूप में स्वीकार किया जाए जो कि एलओए के अनुसरण में रियायत करार करने के दायित्व सहित एलओए के अंतर्गत चयनित बोलीकर्ता के अधिकारों और दायित्वों का निर्वहन और निष्पादन करेगा। रियायतग्राही ने आगे इस हेतु अभिवेदन किया है कि उसे चयनित बोलीकर्ता द्वारा इसमें दिए गए उद्देश्यों के लिए संप्रवर्तित किया है तथा प्राधिकरण को रियायतग्राही द्वारा यह रियायत करार किए जाने और उसके प्रावधानों की प्रवर्तनीयता के प्राधिकार के बारे में कानूनी राय सौंपी है।

छ) प्राधिकरण ने चयनित बोलीकर्ता और रियायतग्राही के उक्त अनुरोध को स्वीकार कर लिया है और तदनुसार इसमें इसके पश्चात् दिए गए निबंधन और शर्तों के अधीन हाइब्रिड वार्षिकी आधार पर परियोजना के कार्यान्वयन के लिए रियायतग्राही के साथ यह रियायत करार करने की स्वीकृति दी है।



ARTICLE 1

DEFINITIONS AND INTERPRETATION

1.1 Definitions

The words and expressions beginning with capital letters and defined in this Agreement (including those in Article 42) shall, unless the context otherwise requires, have the meaning ascribed thereto herein, and the words and expressions defined in the Schedules and used therein shall have the meaning ascribed thereto in the Schedules.

1.2 Interpretation

1.2.1 In this Agreement, unless the context otherwise requires,

- (a) references to any legislation or any provision thereof shall include amendment or re-enactment or consolidation of such legislation or any provision thereof so far as such amendment or re-enactment or consolidation applies or is capable of applying to any transaction entered into hereunder;
- (b) references to laws of India or Indian law or regulation having the force of law shall include the laws, acts, ordinances, rules, regulations, bye laws or notifications which have the force of law in the territory of India and as from time to time may be amended, modified, supplemented, extended or re-enacted;
- (c) references to a "person" and words denoting a natural person shall be construed as a reference to any individual, firm, company, corporation, society, trust, government, state or agency of a state or any association or partnership (whether or not having separate legal personality) of two or more of the above and shall include successors and assigns;
- (d) the table of contents, headings or sub-headings in this Agreement are for convenience of reference only and shall not be used in, and shall not affect, the construction or interpretation of this Agreement;
- (e) the words "include" and "including" are to be construed without limitation and shall be deemed to be followed by "without limitation" or "but not limited to" whether or not they are followed by such phrases;
- (f) references to "construction" or "building" include, unless the context otherwise requires, investigation, design, engineering, procurement, delivery, transportation, installation, processing, fabrication, testing, commissioning and other activities incidental to the construction, and "construct" or "build" shall be construed accordingly;
- (g) references to "development" include, unless the context otherwise requires, construction, renovation, refurbishing, augmentation, upgradation and other activities incidental thereto, and "develop" shall be construed accordingly;

05



PUBLIC PRIVATE PARTNERSHIP IN HYBRID ANNUITY PROJECTS

- (h) any reference to any period of time shall mean a reference to that according to Indian Standard Time;
- (i) any reference to day shall mean a reference to a calendar day;
- (j) Reference to a “**business day**” shall be construed as reference to a day (other than a Sunday) on which banks in the State are generally open for business;
- (k) any reference to month shall mean a reference to a calendar month as per the Gregorian calendar;
- (l) references to any date, period or Project Milestone shall mean and include such date, period or Project Milestone as may be extended pursuant to this Agreement;
- (m) any reference to any period commencing “**from**” a specified day or date and “**till**” or “**until**” a specified day or date shall include both such days or dates; provided that if the last day of any period computed under this Agreement is not a business day, then the period shall run until the end of the next business day;
- (n) the words importing singular shall include plural and vice versa;
- (o) References to any gender shall include the other and the neutral gender;
- (p) “**lakh**” means a hundred thousand (100,000) and “**crore**” means ten million (10,000,000);
- (q) “**Indebtedness**” shall be construed so as to include any obligation (whether incurred as principal or surety) for the payment or repayment of money, whether present or future, actual or contingent;
- (r) references to the “**winding-up**”, “**dissolution**”, “**insolvency**”, or “**reorganisation**” of a company or corporation shall be construed so as to include any equivalent or analogous proceedings under the law of the jurisdiction in which such company or corporation is incorporated or any jurisdiction in which such company or corporation carries on business including the seeking of liquidation, winding-up, reorganisation, dissolution, arrangement, protection or relief of debtors;
- (s) save and except as otherwise provided in this Agreement, any reference, at any time, to any agreement, deed, instrument, license or document of any description shall be construed as reference to that agreement, deed, instrument, license or other document as amended, varied, supplemented, modified or suspended at the time of such reference; provided that this Sub-clause (s) shall not operate so as to increase liabilities or obligations of the Authority hereunder or pursuant hereto in any manner whatsoever;
- (t) any agreement, consent, approval, authorization, notice, communication, information or report required under or pursuant to this Agreement from or by any Party or the Independent Engineer shall be valid and effective only if it is **routed through NHA Data Lake (unless the law requires to send such notice,**



communication, etc, through physical/any other specified mode only) under the hand of a duly authorized representative of such Party or the Independent Engineer, as the case may be, in this behalf and not otherwise;

- (u) the Schedules and Recitals to this Agreement and the Request for Proposals (“RFP”) forms an integral part of this Agreement and will be in full force and effect as though they were expressly set out in the body of this Agreement;
- (v) references to Recitals, Articles, Clauses, Sub-clauses, Provisos or Schedules in this Agreement shall, except where the context otherwise requires, mean references to Recitals, Articles, Clauses, Sub-clauses, Provisos and Schedules of or to this Agreement; reference to an Annex shall, subject to anything to the contrary specified therein, be construed as a reference to an Annex to the Schedule in which such reference occurs; and reference to a Paragraph shall, subject to anything to the contrary specified therein, be construed as a reference to a Paragraph of the Schedule or Annex, as the case may be, in which such reference appears;
- (w) the damages payable by either Party to the other of them, as set forth in this Agreement, whether on per diem basis or otherwise, are mutually agreed genuine pre-estimated loss and damage likely to be suffered and incurred by the Party entitled to receive the same and are not by way of penalty (the “Damages”); and
- (x) Time shall be of the essence in the performance of the Parties’ respective obligations. If any time period specified herein is extended, such extended time shall also be of the essence.

1.2.2 Unless expressly provided otherwise in this Agreement, any Documentation required to be provided or furnished by the Concessionaire to the Authority and/ or the Independent Engineer shall be provided free of cost and in three copies, and if the Authority and/or the Independent Engineer is required to return any such Documentation with their comments and/or approval, they shall be entitled to retain two copies thereof.

1.2.3 The rule of construction, if any, that a contract should be interpreted against the parties responsible for the drafting and preparation thereof, shall not apply.

1.2.4 Any word or expression used in this Agreement shall, unless otherwise defined or construed in this Agreement, bear its ordinary English meaning and, for these purposes, the General Clauses Act 1897 shall not apply.

1.3 **Measurements and arithmetic conventions**

All measurements and calculations shall be in the metric system and calculations done to 2 (two) decimal places, with the third digit of 5 (five) or above being rounded up and below 5 (five) being rounded down.

1.4 **Priority of agreements, clauses and schedules**

07



PUBLIC PRIVATE PARTNERSHIP IN HYBRID ANNUITY PROJECTS

- 1.4.1 This Agreement, and all other agreements and documents forming part of or referred to in this agreement are to be taken as mutually explanatory and, unless otherwise expressly provided elsewhere in this Agreement, the priority of this Agreement and other documents and agreements forming part hereof or referred to herein shall, in the event of any conflict between them, be in the following order:
- (a) this Agreement; and
 - (b) all other agreements and documents forming part hereof or referred to herein,
- i.e. the Agreement at (a) above shall prevail over the agreements and documents at (b) above.
- 1.4.2 Subject to provisions of Clause 1.4.1, in case of ambiguities or discrepancies within this Agreement, the following shall apply:
- (a) between two or more Clauses of this Agreement, the provisions of a specific Clause relevant to the issue under consideration shall prevail over those in other Clauses;
 - (b) between the Clauses of this Agreement and the Schedules, the Clauses shall prevail and between Schedules and Annexes, the Schedules shall prevail;
 - (c) between any two Schedules, the Schedule relevant to the issue shall prevail;
 - (d) between the written description on the Drawings and the Specifications and Standards, the latter shall prevail;
 - (e) between the dimension scaled from the Drawing and its specific written dimension, the latter shall prevail; and
 - (f) between any value written in numerals and that in words, the latter shall prevail.

08



Part II

The Concession

09

Four laning of NH-163 from Hyderabad (ORR Appa Junction) (Design Km 14.000/Existing Km 14.000) to Mamteguda (Design Km 60.405/Existing Km 59.500) (Design Length = 46.405 Km) in the State of Telangana under NH(O) on Hybrid Annuity Mode



ARTICLE 2

SCOPE OF THE PROJECT

2.1 Scope of the Project

The scope of the Project (the “**Scope of the Project**”) shall mean and include, during the Concession Period:

- (a) construction of the Project on the Site set forth in Schedule-A and as specified in Schedule-B together with provision of Project Facilities as specified in Schedule-C, and in conformity with the Specifications and Standards set forth in Schedule-D;
- (b) operation and maintenance of the Project in accordance with the provisions of this Agreement; and
- (c) performance and fulfillment of all other obligations of the Concessionaire in accordance with the provisions of this Agreement and matters incidental thereto or necessary for the performance of any or all of the obligations of the Concessionaire under this Agreement



ARTICLE 3

GRANT OF CONCESSION

3.1 The Concession

3.1.1 Subject to and in accordance with the provisions of this Agreement, Applicable Laws and Applicable Permits, the Authority hereby grants to the Concessionaire the concession set forth herein including the exclusive right, license and authority to construct, operate and maintain the Project (the "Concession") during the Construction Period of 730 (Seven Hundred Thirty) days and Operation Period of 15 (Fifteen) years commencing from COD, and the Concessionaire hereby accepts the Concession and agrees to implement the Project subject to and in accordance with the terms and conditions set forth herein.

3.1.2 Subject to and in accordance with the provisions of this Agreement, the Concession hereby granted shall oblige or entitle (as the case may be) the Concessionaire to:

- (a) Right of Way, access and license to the Site for the purpose of and to the extent conferred by the provisions of this Agreement;
- (b) finance and construct the Project;
- (c) manage, operate and maintain the Project;
- (d) perform and fulfill all of the Concessionaire's obligations under and in accordance with this Agreement;
- (e) save as otherwise expressly provided in this Agreement, bear and pay all costs, expenses and charges in connection with or incidental to the performance of the obligations of the Concessionaire under this Agreement; and
- (f) neither assign, transfer or sublet or create any lien or encumbrance on this Agreement, or the Concession hereby granted or on the whole or any part of the Project nor transfer, lease or part possession thereof, save and except as expressly permitted by this Agreement or the Substitution Agreement.



ARTICLE 4

CONDITIONS PRECEDENT

4.1 Conditions Precedent

4.1.1 Save and except as expressly provided in Articles 4, 5, 6, 7, 8, 9, 10, 22, 28,38 and 41, or unless the context otherwise requires, the respective rights and obligations of the Parties under this Agreement shall be subject to the satisfaction in full of the conditions precedent specified in this Clause 4.1 (the “**Conditions Precedent**”).

4.1.2 The Concessionaire may, upon providing the Performance Security to the Authority in accordance with Article 9, at any time after 30 (thirty) days from the date of this Agreement or on an earlier day acceptable to the Authority, by notice require the Authority to satisfy all of the Conditions Precedent set forth in this Clause 4.1.2 within a period of 120 (one hundred and twenty) days thereafter. The Conditions Precedent required to be satisfied by the Authority shall be deemed to have been fulfilled when the Authority shall have:

- (a) procured for the Concessionaire the Right of Way to the Site in accordance with the provisions of Clauses 10.3.1 and 10.3.2;
- (b) procured all Applicable Permits relating to environmental protection, and conservation in respect land forming part of the Right of Way under Clause 10.3.1 and 10.3.2;
- (c) procured forest clearance for and in respect land forming part of the Right of Way under Clause 10.3.1 and 10.3.2, save and except permission for cutting trees; and
- (d) Deleted.

Provided that the Authority shall be entitled to an additional period, not exceeding 90(ninety) days beyond the period of 150 days without being liable for payment of any damages, for fulfillment of the Conditions Precedent set forth in this Clause.

4.1.3 The Conditions Precedent required to be satisfied by the Concessionaire within a period of 150 (one hundred and fifty) days from the date of this Agreement shall be deemed to have been fulfilled when the Concessionaire shall have:

- (a) provided Performance Security to the Authority along with the Additional Performance Security, if required in terms of Clause 9.1 and Clause 9.7 of this Agreement. For the avoidance of doubt, it is clarified and agreed that the Concessionaire is required to provide the Performance Security and the Additional Performance Security, if required, within 30 days of signing of this Agreement;
- (b) executed and procured execution of the Escrow Agreement;
- (c) executed and procured execution of the Substitution Agreement;
- (d) procured all the Applicable Permits specified in Part-I of Schedule-E unconditionally or if subject to conditions, then all such conditions required to



be fulfilled by the date specified therein shall have been satisfied in full and such Applicable Permits are in full force and effect;

- (e) executed the Financing Agreements and delivered to the Authority 3 (three) true copies thereof, duly attested by a Director of the Concessionaire;
- (f) delivered to the Authority 3 (three) true copies of the Financial Package and the Financial Model, duly attested by a Director of the Concessionaire, along with 3 (three) soft copies of the Financial Model in MS Excel version or any substitute thereof, which is acceptable to the Senior Lenders; and
- (g) delivered to the Authority {from the Consortium Members, their respective} confirmation of the correctness of the representations and warranties set forth in Sub-clauses (k), (l) and (m) of Clause 7.1 of this Agreement.

4.1.4 Each Party shall make all reasonable endeavours to satisfy the Conditions Precedent within the time stipulated and shall provide the other Party with such reasonable cooperation as may be required to assist that Party in satisfying the Conditions Precedent for which that Party is responsible. Subject only to payment of Damages, it is agreed between the Parties that the obligation to fulfill each parties' Conditions Precedent is an independent obligation of the respective Party.

4.1.5 The Parties shall notify each other in writing at least once a month on the progress made in satisfying the Conditions Precedent. Each Party shall promptly inform the other Party when any Condition Precedent for which it is responsible has been satisfied.

4.2 Damages for delay by the Authority

In the event that (i) the Authority does not procure fulfillment of any or all of the Conditions Precedent set forth in Clause 4.1.2 within the period specified in respect thereof, and (ii) the delay has not occurred as a result of breach of this Agreement by the Concessionaire or due to Force Majeure, the Authority shall pay to the Concessionaire Damages in an amount calculated at the rate of 0.2% (zero point two per cent) of the Performance Security for each day's delay until the fulfillment of such Conditions Precedent, **subject to the maximum limit equal to the amount of 1% of the Estimated Project Cost as mentioned in the RFP** and upon reaching such limit, the Concessionaire may, in its sole discretion terminate the Agreement. The Damages payable hereunder shall be the sole remedy available to the Concessionaire for delay by the Authority.

Provided further that in the event of delay by the Concessionaire in procuring fulfillment of the Conditions Precedent specified in Clause 4.1.3, no Damages shall be due or payable by the Authority under this Clause 4.2 until the date on which the Concessionaire shall have procured fulfillment of the Conditions Precedent specified in Clause 4.1.3.

4.3 Damages for delay by the Concessionaire

In the event that (i) the Concessionaire does not procure fulfillment of any or all of the Conditions Precedent set forth in Clause 4.1.3 within the period specified in respect



thereof, and (ii) the delay has not occurred as a result of failure to fulfill the obligations under Clause 4.1.2 or other breach of this Agreement by the Authority, or due to Force Majeure, the Concessionaire shall pay to the Authority Damages in an amount calculated at the rate of 0.3% (zero point three per cent) of the Performance Security for each day's delay until the fulfillment of such Conditions Precedent. Provided, however, that the Damages payable hereunder shall be **subject to the maximum limit equal to the amount of 1% of the Estimated Project Cost as mentioned in the RFP** and upon reaching such limit, the Authority may, in its sole discretion and subject to the provisions of Clause 9.2, terminate the Agreement. Provided further that in the event of delay by the Authority in procuring fulfillment of the Conditions Precedent specified in Clause 4.1.2, no Damages shall be due or payable by the Concessionaire under this Clause 4.3 until the date on which the Authority shall have procured fulfillment of the Conditions Precedent specified in Clause 4.1.2.

4.4 Commencement of Concession Period

The date on which Financial Close is achieved and all the Conditions Precedent specified in Clause 4.1 are satisfied shall be the Appointed Date which shall be the date of commencement of the Concession Period. For the avoidance of doubt, the Parties agree that the Concessionaire may, upon occurrence of the Appointed Date hereunder, by notice convey the particulars thereof to the Authority, and shall thereupon be entitled to commence construction on the Project.

4.5 Deemed Termination upon delay

Without prejudice to the provisions of Clauses 4.2 and 4.3, and subject to the provisions of Clause 9.2, the Parties expressly agree that in the event the Appointed Date does not occur, for any reason whatsoever, before the 1st (first) anniversary of the date of this Agreement or the extended period provided in accordance with this Agreement, all rights, privileges, claims and entitlements of the Concessionaire under or arising out of this Agreement shall be deemed to have been waived by, and to have ceased with the concurrence of the Concessionaire, and the Concession Agreement shall be deemed to have been terminated by mutual agreement of the Parties. Provided, however, that in the event the non-occurrence of the Appointed Date is for reasons attributable to the Concessionaire, the Performance Security and the Additional Performance Security, if any, of the Concessionaire shall be encashed and appropriated by the Authority as Damages thereof.



ARTICLE 5

OBLIGATIONS OF THE CONCESSIONAIRE

5.1 Obligations of the Concessionaire

- 5.1.1 Subject to and on the terms and conditions of this Agreement, the Concessionaire shall, at its own cost and expense, procure finance for and undertake the design, engineering, procurement, construction, operation and maintenance of the Project and observe, fulfill, comply with and perform all its obligations set out in this Agreement or arising hereunder.
- 5.1.2 The Concessionaire shall comply with all Applicable Laws and Applicable Permits (including renewals as required) in the performance of its obligations under this Agreement.
- 5.1.3 Save and except as otherwise provided in this Agreement or Applicable Laws, as the case may be, the Concessionaire shall, in discharge of all its obligations under this Agreement, conform with and adhere to Good Industry Practice at all times.
- 5.1.4 The Concessionaire shall, at its own cost and expense, in addition to and not in derogation of its obligations elsewhere set out in this Agreement:
- (a) make, or cause to be made, necessary applications to the relevant Government Instrumentalities with such particulars and details as may be required for obtaining Applicable Permits, other than those set forth in Clause 4.1.2, and obtain and keep in force and effect such Applicable Permits in conformity with Applicable Laws;
 - (b) procure, as required, the appropriate proprietary rights, licenses, agreements and permissions for materials, methods, processes, know-how and systems used or incorporated into the Project;
 - (c) perform and fulfill its obligations under the Financing Agreements;
 - (d) make reasonable efforts to maintain harmony and good industrial relations among the personnel employed by it or its Contractors in connection with the performance of its obligations under this Agreement;
 - (e) upon written request from the Authority, make reasonable efforts to facilitate the acquisition of land and procuring of environmental and forest clearances required for the purposes of the Agreement;
 - (f) ensure and procure that its Contractors comply with all Applicable Permits and Applicable Laws in the performance by them of any of the Concessionaire's obligations under this Agreement;
 - (g) always act in a manner consistent with the provisions of this Agreement and not cause or fail to do any act, deed or thing, whether intentionally or otherwise, which may in any manner be violative of any of the provisions of this Agreement;



- (h) support, cooperate with and facilitate the Authority in the implementation and operation of the Project in accordance with the provisions of this Agreement; and
- (i) transfer the Project to the Authority upon Termination of this Agreement, in accordance with the provisions of this Agreement.

5.2 Obligations relating to Project Agreements

- 5.2.1 It is expressly agreed that the Concessionaire shall, at all times, be responsible and liable for all its obligations under this Agreement notwithstanding anything contained in the Project Agreements or any other agreement, and no default under any Project Agreement or agreement shall excuse the Concessionaire from its obligations or liability hereunder.
- 5.2.2 The Concessionaire shall submit to the Authority the drafts of all Project Agreements, or any amendments or replacements thereto, for its review and comments, and the Authority shall have the right but not the obligation to undertake such review and provide its comments, if any, to the Concessionaire within 30 (thirty) days of the receipt of such drafts. Within 7 (seven) days of execution of any Project Agreement or amendment thereto, the Concessionaire shall submit to the Authority a true copy thereof, duly attested by a Director of the Concessionaire, for its record. For the avoidance of doubt, it is agreed that the review and comments hereunder shall be limited to ensuring compliance with the terms of this Agreement. It is further agreed that any failure or omission of the Authority to review and/ or comment hereunder shall not be construed or deemed as acceptance of any such agreement or document by the Authority. No review and/ or observation of the Authority and/ or its failure to review and/ or convey its observations on any document shall relieve the Concessionaire of its obligations and liabilities under this Agreement in any manner nor shall the Authority be liable for the same in any manner whatsoever.
- 5.2.3 The Concessionaire shall not make any addition, replacement or amendments to any of the Financing Agreements without the prior written consent of the Authority if such addition, replacement or amendment has, or may have, the effect of imposing or increasing any financial liability or obligation on the Authority, and in the event that any replacement or amendment is made without such consent, the Concessionaire shall not enforce such replacement or amendment nor permit enforcement thereof against the Authority. For the avoidance of doubt, the Authority acknowledges and agrees that it shall not unreasonably withhold its consent for restructuring or rescheduling of the debt of the Concessionaire and shall respond to the request for consent no later than 30 days from the receipt of such request from the Concessionaire.
- 5.2.4 The Concessionaire shall procure that each of the Project Agreements contains provisions that entitle the Authority and / or Lenders Representative to step into such agreement, in its sole discretion, in substitution of the Concessionaire in the event of Termination or Suspension (the "Covenant"). Further, it is clarified that in case both the Authority and Lenders' Representative decide to exercise their right to step-in, the Authority shall have the sole right to step into the Project Agreements. For the



avoidance of doubt, it is expressly agreed that in the event the Authority does not exercise such rights of substitution within a period not exceeding 90 (ninety) days from the Transfer Date, the Project Agreements shall be deemed to cease to be in force and effect on the Transfer Date without any liability whatsoever on the Authority and the Covenant shall expressly provide for such eventuality. The Concessionaire expressly agrees to include the Covenant in all its Project Agreements and undertakes that it shall, in respect of each of the Project Agreements, procure and deliver to the Authority an acknowledgment and undertaking, in a form acceptable to the Authority, from the counter party(ies) of each of the Project Agreements, where under such counter party(ies) shall acknowledge and accept the Covenant and undertake to be bound by the same and not to seek any relief or remedy whatsoever from the Authority in the event of Termination or Suspension.

- 5.2.5 Notwithstanding anything to the contrary contained in this Agreement, the Concessionaire agrees and acknowledges that selection or replacement of the EPC Contractor and an O&M Contractor and execution of the EPC Contract and O&M Contract shall be subject to the prior approval of the Authority from national security and public interest perspective, the decision of the Authority in this behalf being final, conclusive and binding on the Concessionaire, and undertakes that it shall not give effect to any such selection or contract without prior approval of the Authority. For the avoidance of doubt, it is expressly agreed that approval of the Authority hereunder shall be limited to national security and public interest perspective, and the Authority shall endeavor to convey its decision thereon expeditiously and no later than 30 days from the date of receipt of the proposal alongwith the draft agreement by the Authority. It is also agreed that the Authority shall not be liable in any manner on account of grant or otherwise of such approval and that such approval or denial thereof shall not in any manner absolve the Concessionaire or its Contractors from any liability or obligation under this Agreement.

5.3 Obligations relating to Change in Ownership

- 5.3.1 The Concessionaire shall not undertake or permit any Change in Ownership, except with the prior written approval of the Authority.
- 5.3.2 Notwithstanding anything to the contrary contained in this Agreement, the Concessionaire agrees and acknowledges that:
- (a) all acquisitions of Equity by an acquirer, either by himself or with any person acting in concert, directly or indirectly, including by transfer of the direct or indirect legal or beneficial ownership or control of any Equity, in aggregate of 25% (twenty five per cent) or more of the total Equity of the Concessionaire; or
 - (b) acquisition of any control directly or indirectly of the Board of Directors of the Concessionaire by any person either by himself or together with any person or persons acting in concert with him, shall constitute a Change in Ownership requiring prior approval of the Authority from national security and public interest perspective, the decision of the Authority in this behalf being final, conclusive and binding on the Concessionaire, and undertakes that it shall not give effect to any such acquisition of

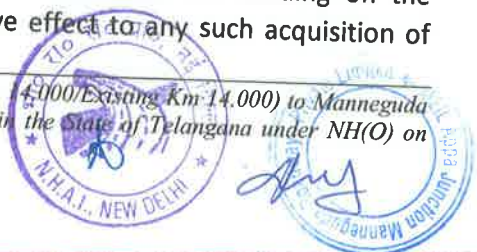

Equity or control of the Board of Directors of the Concessionaire without such prior approval of the Authority. For the avoidance of doubt, it is expressly agreed that approval of the Authority hereunder shall be limited to national security and public interest perspective, and the Authority shall endeavor to convey its decision thereon expeditiously. It is also agreed that the Authority shall not be liable in any manner on account of grant or otherwise of such approval and that such approval or denial thereof shall not in any manner absolve the Concessionaire from any liability or obligation under this Agreement.

For the purposes of this Clause 5.3.2:

- (i) the expression “acquirer”, “control” and “person acting in concert” shall have the meaning ascribed thereto in the Securities and Exchange Board of India (Substantial Acquisition of Shares and Takeover) Regulations, 2011 or any statutory re-enactment thereof as in force as on the date of acquisition of Equity, or the control of the Board of Directors, as the case may be, of the Concessionaire;
- (ii) the indirect transfer or control of legal or beneficial ownership of Equity shall mean transfer of the direct or indirect beneficial ownership or control of any company or companies whether in India or abroad which results in the acquirer acquiring control over the shares or voting rights of shares of the Concessionaire; and
- (iii) power to appoint, whether by contract or by virtue of control or acquisition of shares of any company holding directly or through one or more companies (whether situate in India or abroad) the Equity of the Concessionaire, not less than half of the directors on the Board of Directors of the Concessionaire or of any company, directly or indirectly whether situate in India or abroad, having ultimate control of 25% (twenty five per cent) or more of the Equity of the Concessionaire shall constitute acquisition of control, directly or indirectly, of the Board of Directors of the Concessionaire.

5.4 Obligations relating to employment of foreign nationals

The Concessionaire acknowledges, agrees and undertakes that employment of foreign personnel by the Concessionaire and/or its contractors and their subcontractors shall be subject to grant of requisite regulatory permits and approvals including employment/residential visas and work permits, if any required, and the obligation to apply for and obtain the same shall and will always be of the Concessionaire and, notwithstanding anything to the contrary contained in this Agreement, refusal of or inability to obtain any such permits and approvals by the Concessionaire or any of its contractors or sub-contractors shall not constitute Force Majeure Event, and shall not in any manner excuse the Concessionaire from the performance and discharge of its obligations and liabilities under this Agreement.

5.5 Obligations relating to employment of trained personnel



The Concessionaire shall ensure that the personnel engaged by it in the performance of its obligations under this Agreement are at all times properly trained for their respective function

5.6 Facilities for differently abled and elderly persons

The Concessionaire shall, in conformity with the guidelines issued from time to time by the Ministry of Social Justice and Empowerment, or a substitute thereof, procure a barrier free environment for the differently abled and for elderly persons using the Project.

5.7 Branding of Project

The Project or any part thereof shall not be branded in any manner to advertise, display or reflect the name or identity of the Concessionaire or its shareholders. The Concessionaire undertakes that it shall not, in any manner, use the name or entity of the Project to advertise or display its own identity, brand equity or business interests, including those of its shareholders, save and except as may be necessary in the normal course of business. For the avoidance of doubt, it is agreed that the Concessionaire may display its own name at a spot where other public notices are displayed for the Users. It is further agreed that the Project shall be known, promoted, displayed and advertised by the name of Hyderabad –Maneguda Project

5.8 Sole purpose of the Concessionaire

The Concessionaire having been set up for the sole purpose of exercising the rights and observing and performing its obligations and liabilities under this Agreement, the Concessionaire or any of its subsidiaries shall not, except with the previous written consent of the Authority, be or become directly or indirectly engaged, concerned or interested in any business other than as envisaged herein.

5.9 Obligations relating to Local Content

The Concessionaire [Class I Local Supplier/ Class II Local Supplier/ Non Local Supplier] undertakes to ensure minimum Local Content in the Project Highway of at least [50%/20%] duly complying with the provisions of Department for Promotion of Industry and Internal Trade, Ministry of Commerce and Industry, Government of India Order No. P-45021/2/2017-PP (BEII) dated September 16, 2020, as amended or modified till Bid Due Date and the provisions under Rule 144(xi) of GFR, 2017.



ARTICLE 6

OBLIGATIONS OF THE AUTHORITY

6.1 Obligations of the Authority

- 6.1.1 The Authority shall, at its own cost and expense undertake, comply with and perform all its obligations set out in this Agreement or arising hereunder.
- 6.1.2 The Authority agrees to provide support to the Concessionaire and undertakes to observe, comply with and perform, subject to and in accordance with the provisions of this Agreement and Applicable Laws, the following
- (a) upon written request from the Concessionaire, and subject to the Concessionaire complying with Applicable Laws, provide reasonable support and assistance to the Concessionaire in procuring Applicable Permits required from any Government Instrumentality for implementation and operation of the Project;
 - (b) upon written request from the Concessionaire, provide reasonable assistance to the Concessionaire in obtaining access to all necessary infrastructure facilities and utilities, including water and electricity at rates and on terms no less favorable to the Concessionaire than those generally available to commercial customers receiving substantially equivalent services;
 - (c) procure that no barriers are erected or placed on or about the Project by any Government Instrumentality or persons claiming through or under it, except for reasons of Emergency, national security or law and order;
 - (d) Deleted
 - (e) Subject to and in accordance with Applicable Laws, grant to the Concessionaire the authority to regulate use of the Project;
 - (f) Assist the Concessionaire in procuring police assistance for regulation of Users, removal of trespassers and security on or at the Project;
 - (g) Not do or omit to do any act, deed or thing which may in any manner is violating of any of the provisions of this Agreement;
 - (h) support, cooperate with and facilitate the Concessionaire in the implementation and operation of the Project in accordance with the provisions of this Agreement;
 - (i) upon written request from the Concessionaire and subject to the provisions of Clause 5.4, provide reasonable assistance to the Concessionaire and any expatriate personnel of the Concessionaire or its Contractors to obtain applicable visas and work permits for discharging their respective obligations under this Agreement and the Project Agreements;



- (j) undertake rehabilitation and resettlement of persons affected by construction of the Project and bear all costs and expense in respect thereof, save and except as otherwise provided in this Agreement; and
- (k) subject to the Concessionaire complying with Applicable Laws, provide reasonable support and assistance to the Concessionaire in procuring approvals, other than approval of the General Approval Drawings of the Railway authorities for construction of such road over bridges/under bridges.

6.2 Maintenance obligations prior to Appointed Date

- 6.2.1 During the Development Period, the Concessionaire shall maintain the existing Project Highway, in such a manner so as to ensure that the road is in pothole free condition and also to ensure that the quality of service and safety are maintained and in the event of any material deterioration or damage other than normal wear and tear, the Concessionaire shall undertake repair thereof. It is deemed that the Concessionaire has made necessary provisions for inclusion of costs related to maintenance during the Development Period in its Bid. Provided that in case Appointed Date is not achieved and the Concession Agreement is terminated prior to achievement of Appointed Date, the Concessionaire shall be reimbursed the cost of maintenance during Development Period by the Authority after due certification by the Authorized Representative of the Authority. For the purpose of such reimbursement, the lump sum per kilometer rate of reimbursement for a period of 1 (one) year would be Rs.3.42 lakhs (Three Lakhs and Forty Two Thousand only) and shall be paid on a pro-rata basis for the period concerned. For the avoidance of doubt, the Concessionaire would be reimbursed the cost of maintenance only in case of termination prior to Appointed Date and only if it maintains the Project as envisaged in this Clause 6.2.1.
- 6.2.2 In case of failure of the Concessionaire to undertake maintenance or repair of the Project, the Authority shall undertake maintenance or repair of the Project Highway at the cost and expense of the Concessionaire and recover the said cost as determined by the Independent Engineer from the Performance security, submitted by the Concessionaire. For the avoidance of doubt, the Concessionaire shall undertake repairs only for ensuring safe operation of the Project Highway and in the event of excessive deterioration or damage caused due to unforeseen events such as floods or torrential rain the Authority shall undertake special repairs at its own cost and expense.
- 6.2.3 During the Development Period, the Concessionaire shall protect the Project Highway from any and all occupations, encroachments or Encumbrances, and shall not place or create nor permit any Contractor or other person claiming through or under the Concessionaire to place or create any Encumbrance or security interest over all or any part of the Project Highway or under this Agreement, save and except as otherwise expressly set forth in this Agreement. Further, the Concessionaire shall perform its obligations in a manner that two existing lanes of the Project Highway or an alternative thereof are open to traffic at all times during the Development Period.

6.3 Obligations relating to refinancing



PUBLIC PRIVATE PARTNERSHIP IN HYBRID ANNUITY PROJECTS

Upon request made by the Concessionaire to this effect, the Authority shall, in conformity with any regulations or guidelines that may be notified by the Government or the Reserve Bank of India, as the case may be, permit and enable the Concessionaire to secure refinancing on such terms as may be agreed upon between the Concessionaire and the entity providing such refinancing; provided, however, that the refinancing hereunder shall always be subject to the prior consent of the Authority, which consent shall not be unreasonably withheld. The Authority shall endeavor to convey its decision on such request of the Concessionaire within 30 days of receipt of the proposal by the Authority.



ARTICLE 7

REPRESENTATIONS AND WARRANTIES

7.1 Representations and warranties of the Concessionaire

The Concessionaire represents and warrants to the Authority that:

- (a) It is duly organized and validly existing under the laws of India, and has full power and authority to execute and perform its obligations under this Agreement and to carry out the transactions contemplated hereby;
- (b) it has taken all necessary corporate and other actions under Applicable Laws to authorise the execution and delivery of this Agreement and to validly exercise its rights and perform its obligations under this Agreement;
- (c) {the selected bidder/ Consortium Members and its/their} Associates have the financial standing and resources to fund the required Equity and to raise the debt necessary for undertaking and implementing the Project in accordance with this Agreement;
- (d) this Agreement constitutes its legal, valid and binding obligation, enforceable against it in accordance with the terms hereof, and its obligations under this Agreement -will be legally valid, binding and enforceable obligations against it in accordance with the terms hereof;
- (e) it is subject to the laws of India, and hereby expressly and irrevocably waives any immunity in any jurisdiction in respect of this Agreement or matters arising hereunder including any obligation, liability or responsibility hereunder;
- (f) The information furnished in the Bid and as updated on or before the date of this Agreement is true and accurate in all respects as on the date of this Agreement;
- (g) the execution, delivery and performance of this Agreement will not conflict with, result in the breach of, constitute a default under, or accelerate performance required by any of the terms of its Memorandum and Articles of Association {or those of any member of the Consortium} or any Applicable Laws or any covenant, contract, agreement, arrangement, understanding, decree or order to which it is a party or by which it or any of its properties or assets is bound or affected;
- (h) there are no actions, suits, proceedings, or investigations pending or, to its knowledge, threatened against it at law or in equity before any court or before any other judicial, quasi-judicial or other authority, the outcome of which may result in the breach of this Agreement or which individually or in the aggregate may result in any material impairment of its ability to perform any of its obligations under this Agreement;
- (i) it has no knowledge of any violation or default with respect to any order, writ, injunction or decree of any court or Government Instrumentality which may

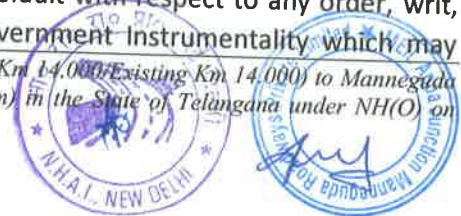

PUBLIC PRIVATE PARTNERSHIP IN HYBRID ANNUITY PROJECTS

result in any material adverse effect on its ability to perform its obligations under this Agreement and no fact or circumstance exists which may give rise to such proceedings that would adversely affect the performance of its obligations under this Agreement;

- (j) it has complied with Applicable Laws in all material respects and has not been subject to any fines, penalties, injunctive relief or any other civil or criminal liabilities which in the aggregate have or may have a material adverse effect on its ability to perform its obligations under this Agreement;
- (k) it shall at no time undertake or permit any Change in Ownership except in accordance with the provisions of Clause 5.3 and that the {selected bidder/ Consortium Members}, together with {its/ their} Associates, hold not less than 51% (fifty-one percent) of its issued and paid up Equity as on the date of this Agreement; and that each Consortium Member whose technical and financial capacity was evaluated for the purposes of pre-qualification and short-listing in response to the Request for Proposals shall hold at least 26% (twenty six per cent) of Equity during the Construction Period and six months thereafter along with its Associates;

Provided further that any such request made under Clause 7.1(k) and / or Article 42, at the option of the Authority, may be required to be accompanied by a suitable no objection letter from Senior Lenders

- (l) {the selected bidder/ each Consortium Member} is duly organized and validly existing under the laws of the jurisdiction of its incorporation or registration, as the case may be, and has requested the Authority to enter into this Agreement with {itself/the Concessionaire} pursuant to the Letter of Award, and has agreed to and unconditionally accepted the terms and conditions set forth in this Agreement;
- (m) all its rights and interests in the Project shall pass to and vest in the Authority on the Transfer Date free and clear of all liens, claims and Encumbrances, without any further act or deed on its part or that of the Authority, and that none of the Project Assets shall be acquired by it Subject to any agreement under which a security interest or other lien or Encumbrance is retained by any person, save and except as expressly provided in this Agreement;
- (n) no representation or warranty by it contained herein or in any other document furnished by it to the Authority or to any Government Instrumentality in relation to Applicable Permits contains or will contain any untrue or misleading statement of material fact or omits or will omit to state a material fact necessary to make such representation or warranty not misleading;
- (o) no sums, in cash or kind, have been paid or will be paid, by it or on its behalf, to any person by way of fees, commission or otherwise for securing the Concession or entering into this Agreement or for influencing or attempting to influence any officer or employee of the Authority in connection therewith;



- (p) all information provided by the {selected bidder/ Consortium Members} in response to the Request for Proposals or otherwise, is to the best of its knowledge and belief, true and accurate in all material respects; and
- (q) All undertakings and obligations of the Concessionaire arising from the Request for Proposals or otherwise shall be binding on the Concessionaire as if they form part of this Agreement.

7.2 Representations and warranties of the Authority

The Authority represents and warrants to the Concessionaire that:

- (a) it has full power and authority to execute, deliver and perform its obligations under this Agreement and to carry out the transactions contemplated herein and that it has taken all actions necessary to execute this Agreement, exercise its rights and perform its obligations, under this Agreement;
- (b) It has taken all necessary actions under Applicable Laws to authorize the execution, delivery and performance of this Agreement;
- (c) It has the financial standing and capacity to perform its obligations under this Agreement;
- (d) This Agreement constitutes a legal, valid and binding obligation enforceable against it in accordance with the terms hereof;
- (e) it has no knowledge of any violation or default with respect to any order, writ, injunction or any decree of any court or any legally binding order of any Government Instrumentality which may result in any material adverse effect on the Authority's ability to perform its obligations under this Agreement;
- (f) It has complied with Applicable Laws in all material respects;
- (g) It has the right, power and authority to manage and operate the Project; and
- (h) It shall procure good and valid right to the Site, and has power and authority to grant a license in respect thereto to the Concessionaire.

7.3 Disclosure

In the event that any occurrence or circumstance comes to the attention of either Party that renders any of its aforesaid representations or warranties untrue or incorrect, such Party shall immediately notify the other Party of the same. Such notification shall not have the effect of remedying any breach of the representation or warranty that has been found to be untrue or incorrect nor shall it adversely affect or waive any right, remedy or obligation of either Party under this Agreement.



ARTICLE 8

DISCLAIMER

8.1 Disclaimer

- 8.1.1 The Concessionaire acknowledges that prior to the execution of this Agreement, the Concessionaire has, after a complete and careful examination, made an independent evaluation of the Request for Proposals, Scope of the Project, Specifications and Standards, Site, existing structures, local conditions, physical qualities of ground, subsoil and geology, and all information provided by the Authority or obtained, procured or gathered otherwise, and has determined to its satisfaction the accuracy or otherwise thereof and the nature and extent of difficulties, risks and hazards as are likely to arise or may be faced by it in the course of performance of its obligations hereunder. The Authority makes no representation whatsoever, express, implicit or otherwise, regarding the accuracy, adequacy, correctness, reliability and/or completeness of any assessment, assumptions, statement or information provided by it and the Concessionaire confirms that it shall have no claim whatsoever against the Authority in this regard.
- 8.1.2 The Concessionaire acknowledges and hereby accepts the risk of inadequacy, mistake or error in or relating to any of the matters set forth in Clause 8.1.1 above and hereby acknowledges and agrees that the Authority shall not be liable for the same in any manner whatsoever to the Concessionaire, {the Consortium Members and their} Associates or any person claiming through or under any of them.
- 8.1.3 The Parties agree that any mistake or error in or relating to any of the matters set forth in Clause 8.1.1 above shall not vitiate this Agreement, or render it voidable.
- 8.1.4 In the event that either Party becomes aware of any mistake or error relating to any of the matters set forth in Clause 8.1.1 above, that Party shall immediately notify the other Party, specifying the mistake or error; provided, however, that a failure on part of the Authority to give any notice pursuant to this Clause 8.1.4 shall not prejudice the disclaimer of the Authority contained in Clause 8.1.1 and shall not in any manner shift to the Authority any risks assumed by the Concessionaire pursuant to this Agreement.
- 8.1.5 Except as otherwise provided in this Agreement, all risks relating to the Project shall be borne by the Concessionaire and the Authority shall not be liable in any manner for such risks or the consequences thereof.



Part III

Development and Operations



ARTICLE 9

PERFORMANCE SECURITY

9.1 Performance Security

- 9.1.1 The Concessionaire shall, for the performance of its obligations hereunder, provide to the Authority no later than 30(thirty) days from the date of this Agreement, an irrevocable and unconditional guarantee from a Bank for a sum equivalent to Rs. 23.55 crore (Rupees Twenty Three crore Fifty Five Lakh only)¹ in the form set forth in Schedule-F (the "Performance Security").
- 9.1.2 Notwithstanding anything to the contrary contained in this Agreement, in the event Performance Security is not provided by the Concessionaire within a period of 30(thirty) days from the date of this Agreement, the Authority may **suspend the bidder for participation in the tendering process for the work of MoRTH/NHAI/NHIDCL and work under other Centrally Sponsored Schemes for a period of One Year from the bid due date of this work**, and thereupon all rights, privileges, claims and entitlements of the Concessionaire under or arising out of this Agreement shall be deemed to have been waived by, and to have ceased with the concurrence of the Concessionaire, and this Agreement shall be deemed to have been terminated by mutual agreement of the Parties.

9.2 Appropriation of Performance Security

Upon occurrence of a Concessionaire Default or failure to meet any Condition Precedent, the Authority shall, without prejudice to its other rights and remedies hereunder or in law, be entitled to encash and appropriate from the Performance Security the amounts due to it for and in respect of such Concessionaire Default or for failure to meet any Condition Precedent. Upon such encashment and appropriation from the Performance Security, the Concessionaire shall, within 15 (fifteen) days thereof, replenish, in case of partial appropriation, to the original level of the Performance Security, and in case of appropriation of the entire Performance Security provide a fresh Performance Security, as the case may be, failing which the Authority shall be entitled to terminate this Agreement in accordance with Article 31.

Provided that upon appropriation on account of Concessionaire's Default the Concessionaire shall replenish the Performance Security and upon such replenishment or furnishing of a fresh Performance Security, as the case may be, the Concessionaire shall be entitled to an additional Cure Period of 120 (one hundred and twenty) days for remedying the Concessionaire Default, save and except as provided in Clause 4.5 of this Agreement, and in the event of the Concessionaire not curing its default within such Cure Period, the Authority shall be entitled to encash and appropriate such Performance Security as Damages, and to terminate this Agreement in accordance with Article 31.

9.3 Release of Performance Security

¹Calculated @ 3% (three per cent) of the Bid Project Cost



The Performance Security shall remain in force and effect for a period of one year from the Appointed Date, but shall be released earlier upon the Concessionaire expending on Project construction an aggregate sum that is not less than 30% (thirty per cent) of the Bid Project Cost; provided, however, that the Performance Security shall not be released and shall be kept alive by the Concessionaire if the Concessionaire is in breach of this Agreement. Upon request made by the Concessionaire for release of the Performance Security along with the particulars which establish satisfaction of the requirements specified in this Clause 9.3, the Authority shall release the Performance Security forthwith.

9.4 Deleted

9.5 Deleted

9.6 References to Performance Security

References to Performance Security occurring in this Agreement for and in respect of any period prior to the delivery of the Performance Security by the Concessionaire to the Authority, or in respect of any period subsequent to the expiry or release thereof, as the case may be, shall be construed solely for the purposes of calculating the amount of Damages payable by the Concessionaire.

9.7 Additional Performance Security

The Concessionaire shall alongwith the Performance Security provide to the Authority an irrevocable and unconditional guarantee from a Bank for a sum equivalent to Rs. ***** crore (Rupees ***** crore) in the form set forth in Schedule-F (the "Additional Performance Security"), to be modified, mutatis mutandis, for this purpose as security to the Authority if the Bid Project Cost of the Selected Bidder is lower by more than 10% with respect to the Estimated Project Cost. The requirement of submitting the Additional Performance Security shall be a Condition Precedent. Failure to maintain the Additional Performance Security shall be treated as Concessionaire Default as per Clause 31.1.1.

Provided that amount of Additional Performance Security shall not exceed the amount of Performance Security.

9.8 Appropriation and Release of Additional Performance Security

Notwithstanding anything contrary contained in this Agreement, if this Agreement is terminated, except for Authority Default or due to the Force Majeure, prior to achievement of the III (third) Project Milestone, the Authority shall have the right to encash the Additional Performance Security in addition to the Performance Security. However, the Additional Performance Security shall be released upon achievement of Project Milestone – III as defined in Schedule G and shall be released immediately and no later than 30 (thirty) days from the certification of achievement of Project Milestone-III.



ARTICLE 10

RIGHT OF WAY

10.1 The Site

The site of the Project shall comprise the real estate described in Schedule-A and in respect of which the Right of Way shall be provided and granted by the Authority to the Concessionaire as a licensee under and in accordance with this Agreement (the "Site"). For the avoidance of doubt, it is hereby acknowledged and agreed that references to the Site shall be construed as references to the real estate required for the Project as set forth in Schedule-A.

10.2 License, Access and Right of Way

- 10.2.1 The Authority hereby grants to the Concessionaire access to the Site for carrying out any surveys, investigations and soil tests that the Concessionaire may deem necessary during the Development Period, it being expressly agreed and understood that the Authority shall have no liability whatsoever in respect of survey, investigations and tests carried out or work undertaken by the Concessionaire on or about the Site pursuant hereto in the event of Termination or otherwise.
- 10.2.2 In consideration of the Project, this Agreement and the covenants and warranties on the part of the Concessionaire herein contained, the Authority, in accordance with the terms and conditions set forth herein, hereby grants to the Concessionaire, commencing from the Appointed Date, leave and license rights in respect of all the land (along with any buildings, constructions or immovable assets, if any, thereon) comprising the Site which is described, delineated and shown in Schedule-A hereto (the "Licensed Premises"), on an "as is where is" basis, free of any Encumbrances, to develop, operate and maintain the said Licensed Premises, together with all and singular rights, liberties, privileges, easements and appurtenances whatsoever to the said Licensed Premises, hereditaments or premises or any part thereof belonging to or in any way appurtenant thereto or enjoyed therewith, for the duration of the Concession Period and, for the purposes permitted under this Agreement, and for no other purpose whatsoever.
- 10.2.3 The license, access and right of way granted by this Agreement to the Concessionaire shall always be subject to existing rights of way and the Concessionaire shall perform its obligations in a manner that two existing lanes of the Project Highway or an alternative thereof are open to traffic at all times during the Construction Period.
- 10.2.4 It is expressly agreed that the license granted hereunder shall terminate automatically and forthwith, without the need for any action to be taken by the Authority to terminate the license, upon the Termination of this Agreement for any reason whatsoever. For the avoidance of doubt, the Parties expressly agree that notwithstanding any temporary or permanent structures erected on the Site by the Concessionaire or its sub-licensees, the license in respect of the Site shall automatically terminate, without any further act of the Parties, upon Termination of this Agreement.



- 10.2.5 The Concessionaire hereby irrevocably appoints the Authority (acting directly or through a nominee) to be its true and lawful attorney, to execute and sign in the name of the Concessionaire a transfer or surrender of the license granted hereunder at any time after the Concession Period has expired or has been terminated earlier in terms hereof, a sufficient proof of which will be the declaration of any duly authorized officer of the Authority, and the Concessionaire consents to it being registered for this purpose.
- 10.2.6 It is expressly agreed that trees on the Site are property of the Authority except that the Concessionaire shall be entitled to exercise usufructuary rights thereon during the Concession Period.

10.3 Procurement of the Site

- 10.3.1 Pursuant to the notice specified in Clause 4.1.2, the Authority Representative and the Concessionaire shall, on a mutually agreed date and time, inspect the Site and prepare a memorandum containing an inventory of the Site including the vacant and unencumbered land, buildings, structures, road works, trees and any other immovable property on or attached to the Site. Such memorandum shall have appended thereto an appendix (the "**Appendix**") specifying in reasonable detail those parts of the Site to which vacant access and Right of Way has not been granted to the Concessionaire. Signing of the memorandum, in 2 (two) counterparts (each of which shall constitute an original), by the authorized representatives of the Parties shall, subject to the provisions of Clause 10.2.2, be deemed to constitute a valid license and Right of Way to the Concessionaire for free and unrestricted use and development of the vacant and unencumbered Site during the Concession Period under and in accordance with the provisions of this Agreement and for no other purpose whatsoever. For the avoidance of doubt, it is agreed that valid license and Right of Way with respect to the parts of the Site as set forth in the Appendix shall be deemed to have been granted to the Concessionaire upon vacant access thereto being provided by the Authority to the Concessionaire.
- 10.3.2 Without prejudice to the provisions of Clause 10.3.1, the Parties hereto agree that on or prior to the Appointed Date, the Authority shall have granted vacant access and Right of Way such that the Appendix shall not include land which shall in any manner prevent the Concessionaire from undertaking construction of the Project to the extent of at least 80% (eighty per cent) of the length thereof, and in the event Financial Close is delayed on account of delay in grant of such vacant access and Right of Way, the Authority shall be liable to payment of Damages solely under the provisions of Clause 4.2. For the avoidance of doubt, the Authority acknowledges and agrees that the Appendix shall not include any land which may prevent the construction of any critical element of the Project without which the Completion Certificate or Provisional Certificate may not be granted. The Authority further acknowledges and agrees that prior to the Appointed Date, it shall have procured issuance of the statutory notification under Applicable Laws for vesting of all land comprising the Project in the Government and has taken possession of at least 80% (eighty per cent) of the length thereof, save and except stray plots of land which the Parties mutually agree to exclude from such vesting prior to the



PUBLIC PRIVATE PARTNERSHIP IN HYBRID ANNUITY PROJECTS

Appointed Date. The Parties also acknowledge and agree that the conditions specified in this Clause 10.3.2 shall not be modified or waived by either Party.

- 10.3.3 On and after signing the memorandum referred to in Clause 10.3.1, and until the Transfer Date, the Concessionaire shall maintain a round-the-clock vigil over the Site and shall ensure and procure that no encroachment thereon takes place, and in the event of any encroachment or occupation on any part thereof, the Concessionaire shall report such encroachment or occupation forthwith to the Authority and undertake its removal at its cost and expenses.
- 10.3.4 The Authority shall make best efforts to procure and grant, no later than 90 (ninety) days from the Appointed Date, the Right of Way to the Concessionaire in respect of all land included in the Appendix, and in the event of delay for any reason other than Force Majeure or breach of this Agreement by the Concessionaire, it shall pay to the Concessionaire Damages in a sum calculated at the rate of Re. 1 (Rupee one) per day for every 10 (ten) square meters or part thereof, commencing from the 91st (ninety first) day of the Appointed Date and until such Right of Way is procured or 180 (one hundred and eighty) days from the Appointed Date whichever is earlier. The Damages payable in terms of this clause shall be the sole remedy available to the Concessionaire and the Authority shall not be liable for any consequential loss or damage to the Concessionaire. In the event, the Authority is unable to provide the remaining Site within 180 (one hundred and eighty days) from the Appointed Date, the remaining Site of the Project Highway shall be removed from the scope of the work under the provision of Change of Scope.
- 10.3.5 Upon receiving Right of Way in respect of any land included in the Appendix, the Concessionaire shall complete the Construction Works thereon within a reasonable period to be determined by the Independent Engineer in accordance with Good Industry Practice; provided that the issue of Provisional Certificate shall not be affected or delayed on account of vacant access to any part of the Site not being granted to the Concessionaire or any construction on such part of the Site remaining incomplete on the date of Tests on account of the delay or denial of such access thereto. For the avoidance of doubt, it is expressly agreed that Construction Works on all lands for which Right of Way is granted within 146(one hundred and forty six) days of the Appointed Date shall be completed on or before the Scheduled Completion Date. It is further agreed that the obligation of the Concessionaire to complete the affected Construction Works shall subsist so long as the Authority continues to pay the Damages specified herein, and upon the Authority ceasing to pay such Damages after giving 60 (sixty) days' notice thereof to the Concessionaire, the obligation of the Concessionaire to complete such works on such part of the Site shall cease forthwith. It is also expressly agreed that completion of the respective Construction Works within the time determined by the Independent Engineer hereunder shall be deemed to be Project Milestones for the purposes of levy and recovery of Damages under and in accordance with the provisions of Clause 12.3.2.
- 10.3.6 The Authority shall procure the additional land required for construction of works specified in Change of Scope Order issued under Article 16, in accordance with the provisions of this Agreement, and upon procurement thereof, such land shall form part

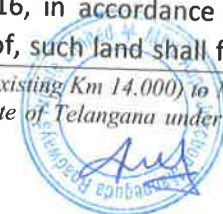

of the Site. In case of any additional land required for Toll Plazas, Traffic Aid Posts, Medical Aid Posts, under passes and over passes or for construction of works specified in Change of Scope Order issued under Article 16, in accordance with this Agreement and upon procurement, such land shall form part of the Site; provided also that the land to be acquired by the Authority hereunder as a part of the Site shall be deemed to be included in the Appendix referred to in this Clause 10.3 and dealt with in accordance with the provisions thereof. For the avoidance of doubt, it is agreed that the minimum area of land to be acquired for the Toll Plaza and approach roads thereof shall conform to the provisions of Schedule - B and Schedule - C.

10.3.7 The Parties expressly agree that the obligation to provide land for 80% (eighty per cent) of the Site shall mean and imply provision of land that shall enable the Concessionaire to undertake construction on at least 80% (eighty per cent) of the length of the Project.

10.4 Site to be free from Encumbrances

Subject to the provisions of Clause 10.3, the Site shall be made available by the Authority to the Concessionaire pursuant hereto free from all Encumbrances and occupations and without the Concessionaire being required to make any payment to the Authority on account of any costs, compensation, expenses and charges for the acquisition and use of such Site for the duration of the Concession Period, except insofar as otherwise expressly provided in this Agreement. For the avoidance of doubt, it is agreed that existing rights of way, easements, privileges, liberties and appurtenances to the Licensed Premises shall not be deemed to be Encumbrances. It is further agreed that the Concessionaire accepts and undertakes to bear any and all risks arising out of the inadequacy or physical condition of the Site.

10.5 Protection of Site from Encumbrances

During the Concession Period, the Concessionaire shall protect the Site from any and all occupations, encroachments or Encumbrances, and shall not place or create nor permit any Contractor or other person claiming through or under the Concessionaire to place or create any Encumbrance or security interest over all or any part of the Site or the Project Assets, or on any rights of the Concessionaire therein or under this Agreement, save and except as otherwise expressly set forth in this Agreement.

10.6 Special/temporary right of way

The Concessionaire shall bear all costs and charges for any special or temporary right of way required by it in connection with access to the Site. The Concessionaire shall obtain at its cost such facilities on or outside the Site as may be required by it for the purposes of the Project and the performance of its obligations under this Agreement.

10.7 Access to the Authority and Independent Engineer

The license, right of way and right to the Site granted to the Concessionaire hereunder shall always be subject to the right of access of the Authority and the Independent Engineer and their employees and agents for inspection, viewing and exercise of their rights and performance of their obligations under this Agreement.



10.8 Geological and archaeological finds

It is expressly agreed that mining, geological or archaeological rights do not form part of the license granted to the Concessionaire under this Agreement and the Concessionaire hereby acknowledges that it shall not have any mining rights or interest in the underlying minerals, fossils, antiquities, structures or other remnants or things either of particular geological or archaeological interest and that such rights, interest and property on or under the Site shall vest in and belong to the Authority or the concerned Government Instrumentality. The Concessionaire shall take all reasonable precautions to prevent its workmen or any other person from removing or damaging such interest or property and shall inform the Authority forthwith of the discovery thereof and comply with such instructions as the Authority or the concerned Government Instrumentality may reasonably give for the removal of such property. For the avoidance of doubt, it is agreed that any reasonable expenses incurred by the Concessionaire hereunder shall be reimbursed by the Authority. It is also agreed that the Authority shall procure that the instructions hereunder are issued by the concerned Government - Instrumentality within a reasonable period so as to enable the Concessionaire to continue its Construction Works with such modifications as may be deemed necessary.

10.9 Land for wayside amenities

- 10.9.1 The additional land earmarked for this purpose in Schedule-A shall be utilized by the Concessionaire for provision of wayside amenities which may include public toilets, rest areas, cafeteria, motels, medical facilities and other facilities or amenities for Users of the Project Highway.
- 10.9.2 The Concessionaire may procure additional land at its own cost and expense for construction and operation of additional facilities and the Authority shall have no obligation or liability in respect thereof. For the avoidance of doubt, the Parties agree that any land acquired by the Concessionaire under this Clause shall be retained by it after the Transfer Date and the Authority shall have no right or lien on such land at any time during or after the Concession Period. The Parties further agree that the Concessionaire shall seek prior consent of the Authority to connect any Additional Facility to the Project and such consent shall not be unreasonably withheld.

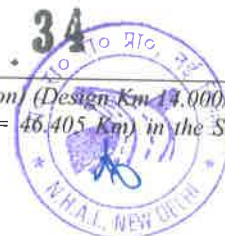

ARTICLE 11

UTILITIES, ASSOCIATED ROADS AND TREES

11.1 Existing utilities and roads

Notwithstanding anything to the contrary contained herein, the Concessionaire shall ensure that the respective entities owning the existing roads, right of way or utilities on, under or above the Site are enabled by it to keep such utilities in continuous satisfactory use, if necessary, by providing suitable temporary or permanent diversions with the authority of the controlling body of that road, right of way or utility, and the Authority shall, upon written request from the Concessionaire, initiate and undertake at the Concessionaire's cost, legal proceedings for acquisition of any right of way necessary for such diversion.

11.2 Shifting of obstructing utilities

11.2.1 The Concessionaire shall, subject to Applicable Laws and with assistance of the Authority, undertake shifting of any utility (including electric lines, water pipes and telephone cables), to an appropriate location or alignment, if such utility or obstruction adversely affects the execution of Works of maintenance of Project Highway in accordance with this Agreement, as per scope given in Schedule B and in accordance with applicable standards and specifications of concerned utility owning entity. The cost of shifting of such utility indicated in Schedule B is payable to the Concessionaire as part of Bid Project Cost. Cost of Shifting utilities not included in Schedule B, if any, shall be treated as Change of Scope. The Authority will provide assistance to the Concessionaire for obtaining the estimates for shifting of such utilities from the entity owning such electric lines, water pipes or telephone cables, as the case may be. The Concessionaire shall execute such utility shifting works under the supervision of utility owning agency and Independent Engineer (IE) in accordance with the provision of Agreement. The supervision charge only shall be paid by Authority to the Utility Owning Entity. In the event of any delay in shifting thereof, the Concessionaire shall be responsible for failure to perform any of its obligations here under if such failure is not as a direct consequence of delay on the part of entity owning such electric lines, water pipes or telephone cables as the case may be.

The dismantled material/scrap of existing Utility to be shifted/dismantled shall belong to the Concessionaire who would be free to dispose-off the dismantled material as deemed fit by them.

The work of shifting of Utilities can be taken up by the Concessionaire any time after signing of the Agreement.

11.2.2 In case Appointed Date is not achieved and the Concession Agreement is terminated prior to achievement of Appointed Date, the Concessionaire shall be reimbursed the cost of utility shifting carried out during Development Period by the Authority after due certification by the Authorised Representative of the Authority. For the purpose of such reimbursement, the rates in approved estimates by the concerned utility department shall be paid as per actual work carried out at site. For the avoidance of doubt, the Concessionaire would be reimbursed the cost of utility shifting only in case of termination prior to Appointed Date and only if it carry out the utility shifting as envisaged in clause 11.2.1



11.3 New utilities and roads

The Concessionaire shall allow, subject to such conditions as the Authority may specify, access to, and use of the Site for laying telephone lines, water pipes, electric cables or other public utilities. Where such access or use causes any financial loss to the Concessionaire, it may require the user of the Site to pay compensation or damages as per Applicable Laws. For the avoidance of doubt, it is agreed that use of the Site under this Clause 11.3 shall not in any manner relieve the Concessionaire of its obligation to maintain the Project in accordance with this Agreement and any damage caused by such use shall be restored forthwith.

11.4 Felling of trees

The Authority shall assist the Concessionaire in obtaining the Applicable Permits for felling of trees to be identified by the Authority for this purpose if and only if such trees cause a material adverse effect on the construction, operation or maintenance of the Project Highway. The cost of such felling shall be borne by the Authority, and in the event of any delay in felling thereof for reasons beyond the control of the Concessionaire, it shall be excused for failure to perform any of its obligations hereunder if such failure is a direct consequence of delay in the felling of trees. For the avoidance of doubt, the Parties hereto agree that the felled trees shall be deemed to be owned by the Authority and shall be disposed in such manner and subject to such conditions as the Authority may in its sole discretion deem appropriate.



ARTICLE 12

CONSTRUCTION OF THE PROJECT

12.1 Obligations prior to commencement of construction

In addition to its obligations of maintaining the Project Highway during the Development Period, prior to commencement of Construction Works, the Concessionaire shall:

- (a) submit to the Authority and the Independent Engineer its detailed design, construction methodology, quality assurance procedures, and the procurement, engineering and construction time schedule for completion of the Project in accordance with the Project Completion Schedule as set forth in Schedule-G;
- (b) Appoint its representative duly authorized to deal with the Authority in respect of all matters under or arising out of or relating to this Agreement;
- (c) undertake, do and perform all such acts, deeds and things as may be necessary or required before commencement of construction under and in accordance with this Agreement, Applicable Laws and Applicable Permits; and
- (d) Make its own arrangements for quarrying and procurement of materials needed for the Project under and in accordance with Applicable Laws and Applicable Permits.

12.2 Drawings

In respect of the Concessionaire's obligations relating to the Drawings of the Project as set forth in Schedule-H, the following shall apply:

- (a) The Concessionaire shall prepare and submit, with reasonable promptness and in such sequence as is consistent with the Project Completion Schedule, 3 (three) copies each of all Drawings to the Independent Engineer for review.
- (b) By submitting the Drawings for review to the Independent Engineer, the Concessionaire shall be deemed to have represented that it has determined and verified that the design and engineering, including the field construction criteria related thereto, are in conformity with the Scope of the Project, Specifications and Standards, Applicable Laws and Good Industry Practice.
- (c) Within 15 (fifteen) days of the receipt of the Drawings, the Independent Engineer shall review the same and convey its observations to the Concessionaire with particular reference to their conformity or otherwise with the Scope of the Project and the Specifications and Standards. The Concessionaire shall not be obliged to await the observations of the Independent Engineer on the Drawings submitted pursuant hereto beyond the said 15 (fifteen) days period and may begin or continue Construction Works at its own discretion and risk.
- (d) If the aforesaid observations of the Independent Engineer indicate that the Drawings are not in conformity with the Scope of the Project or the Specifications and

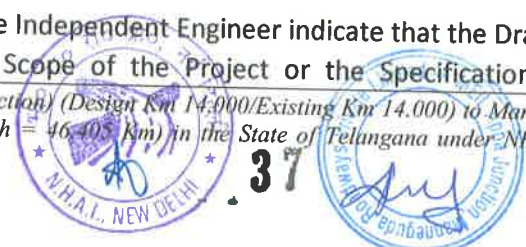

Standards, such Drawings shall be revised by the Concessionaire and resubmitted to the Independent Engineer for review. The Independent Engineer shall give its observations, if any, within 7 (seven) days of receipt of the revised Drawings.

- (e) No review and/or observation of the Independent Engineer and/or its failure to review and/or convey its observations on any Drawings shall relieve the Concessionaire of its obligations and liabilities under this Agreement in any manner nor shall the Independent Engineer or the Authority be liable for the same in any manner.
- (f) Without prejudice to the foregoing provisions of this Clause 12.2, the Concessionaire shall submit to the Authority for review and comments, its Drawings relating to alignment of the Project, finished road level and general arrangement drawings of major bridges, flyovers and grade separators, and the Authority shall have the right but not the obligation to undertake such review and provide its comments, if any, within 30 (thirty) days of the receipt of such Drawings. The provisions of this Clause 12.2 shall apply mutatis mutandis to the review and comments hereunder.
- (g) Within 90 (ninety) days of COD, the Concessionaire shall furnish to the Authority and the Independent Engineer a complete set of as-built Drawings, in 2 (two) hard copies and in its editable digital format or in such other medium or manner as may be acceptable to the Authority, reflecting the Project as actually designed, engineered and constructed, including an as-built survey illustrating the layout of the Project and setback lines, if any, of the buildings and structures forming part of Project Facilities.

12.3 Construction of the Project

- 12.3.1 On or after the Appointed Date, the Concessionaire shall undertake construction of the Project as specified in Schedule-B and Schedule-C, and in conformity with the Specifications and Standards set forth in Schedule-D. The 730th (Seven Hundred and Thirtieth) day from the Appointed Date shall be the scheduled date for completion of the Project (the "**Scheduled Completion Date**") and the Concessionaire agrees and undertakes that the Project shall be completed on or before the Scheduled Completion Date.
- 12.3.2 The Concessionaire shall construct the Project in accordance with the Project Completion Schedule set forth in Schedule-G. In the event that the Concessionaire fails to achieve any Project Milestone within a period of 90 (ninety) days from the date set forth for such Project Milestone in Schedule-G, unless such failure has occurred due to Force Majeure or for reasons attributable to the Authority, it shall pay Damages to the Authority in a sum calculated at the rate of 0.1% (zero point one per cent) of the amount of Performance Security for delay of each day until such Project Milestone is achieved; provided that if any or all Project Milestones or the Scheduled Completion Date are extended in accordance with the provisions of this Agreement, the dates set forth in Schedule-G shall be deemed to be modified accordingly and the provisions of this Agreement shall apply as if Schedule-G has been amended as above; provided further



that in the event COD is achieved on or before the Scheduled Completion Date, the Damages paid under this Clause 12.3.2 shall be refunded by the Authority to the Concessionaire, but without any interest thereon. For the avoidance of doubt, it is agreed that recovery of Damages under this Clause 12.3.2 shall be without prejudice to the rights of the Authority under this Agreement, including the right of Termination thereof.

12.3.3 In the event that the Project is not completed and COD does not occur within 270 (two hundred and seventy) days from the Scheduled Completion Date, unless the delay is on account of reasons attributable to the Authority or due to Force Majeure, the Authority shall be entitled to terminate this Agreement.

12.4 Maintenance during Construction Period

12.4.1 During the Construction Period, the Concessionaire shall maintain, at its cost, the existing Project Highway to ensure that the road is in pothole free condition is maintained, and shall undertake the necessary repair and maintenance works for this purpose; provided that the Concessionaire may, at its cost, interrupt and divert the Users and other persons if such interruption and diversion is necessary for the efficient progress of Construction Works and conforms to Good Industry Practice; provided further that such interruption and diversion shall be undertaken by the Concessionaire only with the prior written approval of the Independent Engineer which approval shall not be unreasonably withheld. **Further, in case the Scheduled Completion Date gets extended due to delay attributable solely to the Authority, the Concessionaire shall be liable to maintain the Project Highway for such extended period and shall be entitled to receive reimbursement of cost of maintenance for such extended period at the rate specified in Clause 6.2.1** For the avoidance of doubt, it is agreed that the Concessionaire shall at all times be responsible for ensuring safe operation of the Project.

12.4.2 In the event of default by the Concessionaire in discharging the obligations specified in Clause 12.4.1, the Authority may levy and recover Damages equal to 0.2% (zero point two per cent) of the Performance Security for each day of default hereunder.

12.4.3 The Parties expressly agree that pursuant to the provisions of Clause 12.4.1, the Concessionaire shall, about 7 (seven) days prior to the date of this Agreement and with prior notice to the Authority and alongwith the Authority's Representative, undertake video recording of the condition and status of the Project, which recording shall be compiled into a 3 (three)-hour digital video disc or any substitute thereof, and shall provide 3 (three) copies of such recording to the Authority within 2 (two) days of the date of this Agreement. The Authority may, in its discretion, undertake another video recording in the presence of the Concessionaire's representative, within 7 (seven) days of the date of this Agreement, and substitute its video recording for the video recording undertaken by the Concessionaire. The Parties further agree that such video recording shall constitute evidence of the status and condition of the Project as on the date of such recording.

12.5 Deleted



ARTICLE 13

MONITORING OF CONSTRUCTION

13.1 Monthly progress reports

During the Construction Period, the Concessionaire shall, no later than 7 (seven) days after the close of each month, furnish to the Authority and the Independent Engineer a monthly report on physical and financial progress of the Construction Works and shall promptly give such other relevant information as may be required by the Independent Engineer.

13.2 Inspection

During the Construction Period, the Independent Engineer shall inspect the Project at least once a month and make a report of such inspection (the "Inspection Report") stating in reasonable detail the defects or deficiencies, if any, with particular reference to the Project Completion Schedule, Scope of the Project and Specifications and Standards. It shall send a copy of the Inspection Report to the Authority and the Concessionaire within 7 (seven) days of such inspection and upon receipt thereof, the Concessionaire shall rectify and remedy the defects or deficiencies, if any, stated in the Inspection Report. Such inspection or submission of Inspection Report by the Independent Engineer shall not relieve or absolve the Concessionaire of its obligations and liabilities hereunder in any manner whatsoever.

13.3 Tests

13.3.1 For determining that the Construction Works conform to the Specifications and Standards, the Independent Engineer shall require the Concessionaire to carry out or cause to be carried out tests, at such time and frequency and in such manner as may be specified by the Independent Engineer from time to time, in accordance with Good Industry Practice for quality assurance. The size of sample for such tests shall, to the extent possible, not exceed 10% (ten per cent) of the quantity and/or number of tests required by Good Industry Practice for the construction works undertaken by the Authority through their contractors. The Concessionaire shall, with due diligence, carry out or cause to be carried out all the tests in accordance with the instructions of the Independent Engineer and furnish the results thereof to the Independent Engineer. One half of the costs incurred on such tests, and to the extent certified by the Independent Engineer as reasonable, shall be reimbursed by the Authority to the Concessionaire. Provided, however, that the Independent Engineer may, instead of carrying out the tests specified hereunder, at its option decide to witness, or participate in, any of the tests to be undertaken by the Concessionaire for its own quality assurance in accordance with Good Industry Practice, and in such an event, the Concessionaire shall cooperate with, and provide the necessary assistance to, the Independent Engineer for discharging its functions hereunder. For the avoidance of doubt, the costs to be incurred on any test which is undertaken for determining the rectification of any defect or deficiency in construction shall be borne solely by the Concessionaire.



13.3.2 In the event that results of any tests conducted under this Clause 13.3 establish any defects or deficiencies in the Construction Works, the Concessionaire shall carry out remedial measures and furnish a report to the Independent Engineer in this behalf. The Independent Engineer shall require the Concessionaire to carry out or cause to be carried out tests to determine that such remedial measures have brought the Construction Works into compliance with the Specifications and Standards, and the procedure set forth in this Clause 13.3 shall be repeated until such Construction Works conform to the Specifications and Standards. For the avoidance of doubt, it is agreed that tests pursuant to this Clause 13.3 shall be undertaken in addition to and independent of the tests that shall be carried out by the Concessionaire for its own quality assurance in accordance with Good Industry Practice. It is also agreed that a copy of the results of such tests shall be sent by the Concessionaire to the Independent Engineer forthwith.

13.4 Delays during construction

Without prejudice to the provisions of Clause 12.3.2, if the Concessionaire does not achieve any of the Project Milestones or the Independent Engineer shall have reasonably determined that the rate of progress of Construction Works is such that the Project is not likely to be completed by the Scheduled Completion Date, it shall notify the Concessionaire to this effect, and the Concessionaire shall, within 15 (fifteen) days of such notice, by a communication inform the Independent Engineer in reasonable detail about the steps it proposes to take to expedite progress and the period within which it shall achieve COD.

13.5 Suspension of unsafe Construction Works

13.5.1 Upon recommendation of the Independent Engineer to this effect, the Authority may by notice require the Concessionaire to suspend forthwith the whole or any part of the Construction Works if, in the reasonable opinion of the Authority, Such work threatens the safety of the Users and pedestrians. Provided, however, that in case of an emergency, the Authority may suo moto issue the notice referred to hereinabove.

13.5.2 The Concessionaire shall, pursuant to the notice under Clause 13.5.1, suspend the Construction Works or any part thereof for such time and in such manner as may be specified by the Authority and thereupon carry out remedial measures to secure the safety of suspended works and the Users. The Concessionaire may by notice require the Independent Engineer to inspect such remedial measures forthwith and make a report to the Authority recommending whether or not the suspension hereunder may be revoked. Upon receiving the recommendations of the Independent Engineer, the Authority shall either revoke such suspension or instruct the Concessionaire to carry out such other and further remedial measures as may be necessary in the reasonable opinion of the Authority, and the procedure set forth in this Clause 13.5 shall be repeated until the suspension hereunder is revoked.

13.5.3 Subject to the provisions of Clause 28.7, all reasonable costs incurred for maintaining and protecting the Construction Works or part thereof during the period of suspension (the "Preservation Costs") shall be borne by the Concessionaire; provided that if the



suspension has occurred as a result of any breach of this Agreement by the Authority, the Preservation Costs shall be borne by the Authority.

13.5.4 If suspension of Construction Works is for reasons not attributable to the Concessionaire, the Independent Engineer shall determine any extension of the dates set forth in the Project Completion Schedule to which the Concessionaire is reasonably entitled, and shall notify the Authority accordingly whereupon the Authority shall extend such Project Completion Schedule dates in accordance with the recommendations of the Independent Engineer.

13.6 Video recording

The Concessionaire shall during the Construction Period and Maintenance Period (every month since award of work till completion of construction and biannually during O&M period) shall carry out such drone videography in the presence of Team Leader of Independent Engineer. The video of last month and the current month running side by side shall be uploaded on Data Lake (<https://datalakeg.nhai.gov.in/nhai>) for easily capturing various developments during the month (a sample screenshot is attached herewith and also loaded on Data Lake along with a sample video for guidance) before submission of their invoice. Capturing Ortho-image for approx. 10% equivalent length of critical structures or any other specific area should be decided by the ROs/ PDs and be conveyed to the Drone Agency in the site-specific work order. Independent Engineer shall ensure that the features and quality of drone video is acceptable and video is not distorted/tampered with.

Independent Engineer shall analyse these drone videos and give their comments in its digital MPRs covering inter-alia but not limited to the encumbrances/lands not available, sites of COS demands, progress of project, mobilisation of plant & equipment, mobilisation of camp sites, progress on rectification of NCRs etc. alongwith the proposed action plan. Project Director of NHAI shall cross-check drone videos during the monthly physical inspections and notify the discrepancies noticed, if any, between drone video, on Independent Engineer comments and ground reality. The discrepancies shall be examined and addressed through joint site inspections.

As per the policy, the Network Survey Vehicle (NSV) survey needs to be carried out twice in a year on completed project. Therefore, PDs should plan biannually drone based video recording during O&M period in such a manner so that there is no overlap and digital data of O&M period is available in regular intervals (quarterly) through NSV and drone videography.

In addition, PDs/ ROs can also undertake need based drone videography as and when required. PD shall ensure development of a project specific website by the Concessionaire for all project being executed under HAM as per Clause 13.6 of the agreement, where Concessionaire needs to upload Video and time stamp pictures every week regarding progress. The website must be accessible to the public. In case of default on this account, the PD shall withhold an amount equivalent to Rs. 5 Lacs plus



PUBLIC PRIVATE PARTNERSHIP IN HYBRID ANNUITY PROJECTS

(drone rate X length of project X no. of defaulting week) from the dues to the Concessionaire.

Home / Drone Videos

Select Project: All | Select From Date: 03/11/2021 | Select To Date: 03/11/2021 | Select Month: November-2021

NOTE
 1) Above Filter is based on Duration of Drone Video Survey From Date.
 2) To Filter Data, Please select From Date and To Date or Select Month.
 3) Drone Video download will be based on your internet speed. In case of any issue, please RESUME the download from Download bar of Browser.

Video Preview	#	Status	RAMS Status	Instructions to PD	CGM	State	RO	PIU	Unique Project Code	Project Name	Duration of Drone Video Survey (From)	Duration of Drone Video Survey (To)	From Chainage	To Chainage	Drone Survey Agency	Date of forwarding letter of contractor	Letter No
	1	Submitted by Contractor			CGM-AP	Jharkhand	RO-Ranchi	Daltonganj	N0800303001/JH	4L from km 1	28/10/2021	28/10/2021	196 8700	219 6000	Other	02/11/2021	RGI-PL/20-21/NH-75/128
	2	Submitted by PIU			CGM-HR	Haryana	RO-Chandigarh (HR)	Sonapat	N0502101001/HR	Rohat-Panip	27/10/2021	27/10/2021	0	80 8380	Other	02/11/2021	445
	3	Submitted by PIU			CGM-DL	Haryana	RO-Delhi	Ghaziabad	N0100501002/HR	Eastern Perip	25/10/2021	28/10/2021	1	22	Other	01/11/2021	1250/October
	4	Submitted by PIU			CGM-HR	Haryana	RO-Chandigarh (HR)	Sonapat	N0300806003/HR	Gohana - So	25/10/2021	25/10/2021	40.8010	78 8370	Other	01/11/2021	569

Home / Drone Videos

NOTE
 1) Above Filter is based on Duration of Drone Video Survey From Date.
 2) To Filter Data, Please select From Date and To Date or Select Month.
 3) Drone Video download will be based on your internet speed. In case of any issue, please RESUME the download from Download bar of Browser.

Video Preview

AERIAL VIDEOGRAPHY OF 706-B (AKSHARPHAM TO EPE) PACKAGE-2 FROM 14+750KM TO 31+599KM

Video Preview	#	Status	RAMS Status	Instructions to PD	CGM	State	RO	PIU	Unique Project Code	Project Name	Duration of Drone Video Survey (From)	Duration of Drone Video Survey (To)	From Chainage	To Chainage	Drone Survey Agency	Date of forwarding letter of contractor	Letter No
	6	Submitted by PIU															
	7	Submitted by PIU															
	8	Submitted by PIU															
	9	Submitted by PIU															
	10	Submitted by PIU			CGM-BV	Uttar Pradesh	RO-Delhi	Ghaziabad	N040001002/UP	DUP Road	25/10/2021	28/10/2021	14.750	31.690	Other	01/11/2021	1250/October

43



Four laning of NH-10
 (Design Km 60.405/EPE)
 Hybrid Annuity Mode

NOTE
 1) Above Filter is based on Duration of Drone Video Survey From Date.
 2) To Filter Data, Please select From Date and To Date or Select Month.
 3) Drone Video download will be based on your internet speed. In case of any issue, please RESUME the download from Download bar of Browser.

ARTICLE 14
COMPLETION CERTIFICATE

14.1 Tests

14.1.1 No later than 30 (thirty) days prior to the likely completion of the Project, the Concessionaire shall notify the Independent Engineer of its intent to subject the Project to Tests. The date and time of each of the Tests shall be determined by the Independent Engineer in consultation with the Concessionaire, and notified to the Authority who may designate its representative to witness the Tests. The Concessionaire shall provide such assistance as the Independent Engineer may reasonably require for conducting the Tests. In the event of the Concessionaire and the Independent Engineer failing to mutually agree on the dates for conducting the Tests, the Concessionaire shall fix the dates by not less than 10 (ten) days' notice to the Independent Engineer, and in the event the Independent Engineer delays the Tests hereunder, the Authority shall impose exemplary penalties on the Independent Engineer and shall ensure that Tests are completed in time either by the Independent Engineer or any substitute thereof.

14.1.2 All Tests shall be conducted in accordance with Schedule-I at the cost and expense of the Concessionaire. The Independent Engineer shall observe, monitor and review the results of the Tests to determine compliance of the Project with Specifications and Standards and if it is reasonably anticipated or determined by the Independent Engineer during the course of any Test that the performance of the Project or any part thereof does not meet the Specifications and Standards, it shall have the right to suspend or delay such Test and require the Concessionaire to remedy and rectify the defects or deficiencies. Upon completion of each Test, the Independent Engineer shall provide to the Concessionaire and the Authority copies of all Test data including detailed Test results. For the avoidance of doubt, it is expressly agreed that the Independent Engineer may require the Concessionaire to carry out or cause to be carried out additional Tests, in accordance with Good Industry Practice, for determining the compliance of the Project with Specifications and Standards.

14.2 Completion Certificate

Upon completion of Construction Works and the Independent Engineer determining the Tests to be successful, it shall forthwith issue to the Concessionaire and the Authority a certificate substantially in the form set forth in Schedule-J (the "**Completion Certificate**").

14.3 Provisional Certificate

14.3.1 Subject to the provisions of Clause 14.3.2, the Independent Engineer may, at the request of the Concessionaire, issue a provisional certificate of completion substantially in the form set forth in Schedule-J (the "**Provisional Certificate**") if the Tests are successful and the Project can be safely and reliably placed in commercial operation though certain works or things forming part thereof are outstanding and not yet complete. In such an



event, the Provisional Certificate shall have appended thereto a list of outstanding items signed jointly by the Independent Engineer and the Concessionaire (the "Punch List"); provided that the Independent Engineer shall not withhold the Provisional Certificate for reason of any work remaining incomplete if the delay in completion thereof is attributable to the Authority; provided further that the Punch List shall also include the cost of completion for each of the outstanding items.

14.3.2 The Parties hereto expressly agree that a Provisional Certificate under this Clause 14.3 may, upon request of the Concessionaire to this effect, be issued for operating part of the Project, if the Concessionaire has completed construction of 100% (Hundred per cent) of the Site made available to the Concessionaire up to 146 days from the Appointed Date. Upon issue of such Provisional Certificate, the provisions of Article 15 shall apply to such completed part, and the rights and obligations of the Concessionaire for and in respect of such completed part of the Project shall be construed accordingly.

14.4 Completion of Punch List items

14.4.1 All items in the Punch List shall be completed by the Concessionaire within 90 (ninety) days of the date of issue of the Provisional Certificate and for any delay thereafter, other than for reasons solely attributable to the Authority or due to Force Majeure, the Authority shall be entitled to recover Damages from the Concessionaire to be calculated and paid for each day of delay until all items are completed, at the lower of (a) 0.1% (zero point one per cent) of the Performance Security, and (b) 0.2% (zero point two per cent) of the cost of completing such items as estimated by the Independent Engineer. Subject to payment of such Damages, the Concessionaire shall be entitled to a further period not exceeding 120 (one hundred and twenty) days for completion of the Punch List items. For the avoidance of doubt, it is agreed that if completion of any item is delayed for reasons solely attributable to the Authority or due to Force Majeure, the completion date thereof shall be determined by the Independent Engineer in accordance with Good Industry Practice, and such completion date shall be deemed to be the date of issue of the Provisional Certificate for the purposes of Damages, if any, payable for such item under this Clause 14.4.1.

14.4.2 Upon completion of all Punch List items, the Independent Engineer shall issue the Completion Certificate. Failure of the Concessionaire to complete all the Punch List items within the time set forth in Clause 14.4.1 for any reason, other than conditions constituting Force Majeure or for reasons solely attributable to the Authority, shall entitle the Authority to terminate this Agreement.

14.5 Withholding of Provisional or Completion Certificate

14.5.1 If the Independent Engineer determines that the Project or any part thereof does not conform to the provisions of this Agreement and cannot be safely and reliably placed in commercial operation, it shall forthwith make a report in this behalf and send copies thereof to the Authority and the Concessionaire. Upon receipt of such a report from the Independent Engineer and after conducting its own inspection, if the Authority is of the opinion that the Project is not fit and safe for commercial service, it shall, within 7 (seven) days of receiving the aforesaid report, notify the Concessionaire of the defects



and deficiencies in the Project and direct the Independent Engineer to withhold issuance of the Provisional Certificate or Completion Certificate, as the case may be. Upon receipt of such notice, the Concessionaire shall remedy and rectify such defects or deficiencies and thereupon Tests shall be undertaken in accordance with this Article 14. Such procedure shall be repeated as necessary until the defects or deficiencies are rectified.

14.5.2 Notwithstanding anything to the contrary contained in Clause 14.5.1, the Authority may, at any time after receiving a report from the Independent Engineer under that Clause, direct the Independent Engineer to issue a Provisional Certificate under Clause 14.3, and such direction shall be complied forthwith.

14.6 Rescheduling of Tests

If the Independent Engineer certifies to the Authority and the Concessionaire that it is unable to issue the Completion Certificate or Provisional Certificate, as the case may be, because of events or circumstances on account of which the Tests could not be held or had to be suspended, the Concessionaire shall be entitled to re-schedule the Tests and hold the same as soon as reasonably practicable.



ARTICLE 15

ENTRY INTO COMMERCIAL SERVICE

15.1 Commercial Operation Date (COD)

15.1.1 The Project shall be deemed to be complete when the Completion Certificate or the Provisional Certificate, as the case may be, is issued under the provisions of Article 14, and accordingly the commercial operation date of the Project shall be the date on which such Completion Certificate or the Provisional Certificate is issued (the "COD"). The Project shall enter into commercial service on COD whereupon the Concessionaire shall be entitled to demand and collect Annuity Payments in accordance with the provisions of this Agreement.

15.2 Damages for delay

Subject to the provisions of Clause 12.3, if COD does not occur prior to the 91st (ninety first) day after the Scheduled Completion Date, unless the delay is on account of reasons attributable to the Authority or due to Force Majeure, the Concessionaire shall pay Damages to the Authority in a sum calculated at the rate of 0.2% (zero point two per cent) of the amount of Performance Security for delay of each day until COD is achieved. Upon failure of the Concessionaire to pay the said Damages, the same shall be paid alongwith interest of Bank Rate plus 3% and shall be deducted from the 1st (first) Annuity Payment. In case the Damages and the interest thereof are more than the 1st Annuity payment then the balance Damages alongwith interest thereof shall be recovered from any further amount due and payable to the Concessionaire excluding O&M Payments but including interest to be paid on reducing balance of the Completion Cost remaining to be paid along with the 1st Annuity or from further Annuity payments.



ARTICLE 16

CHANGE OF SCOPE

16.1 Change of Scope

16.1.1 The Authority may, notwithstanding anything to the contrary contained in this Agreement, require the provision of additional works and services which are not included in the Scope of the Project as contemplated by this Agreement (the “**Change of Scope**”). Any such Change of Scope shall be made in accordance with the provisions of this Article 16 and the costs thereof shall be expended by the Concessionaire and reimbursed to it by the Authority in accordance with Clause 16.3.

16.1.2 If the Concessionaire determines at any time that a Change of Scope is necessary for providing safer and improved services to the Users, it shall by notice in writing require the Authority to consider such Change of Scope. The Authority shall, within 15 (fifteen) days of receipt of such notice, either accept such Change of Scope with modifications, if any, and initiate proceedings therefor in accordance with this Article 16 or inform the Concessionaire in writing of its reasons for not accepting such Change of Scope, which decision of the Authority shall be final and binding.

16.1.3 Any works or services which are provided under and in accordance with this Article 16 shall form part of the Project and the provisions of this Agreement shall apply mutatis mutandis to such works or services.

16.2 Procedure for Change of Scope

16.2.1 In the event of the Authority determining that a Change of Scope is necessary, it shall issue to the Concessionaire a notice specifying in reasonable detail the works and services contemplated thereunder (the “**Change of Scope Notice**”).

16.2.2 Upon receipt of a Change of Scope Notice, the Concessionaire shall, with due diligence, provide to the Authority such information as is necessary, together with preliminary Documentation in support of:

- (a) the impact, if any, which the Change of Scope is likely to have on the Project Completion Schedule if the works or services are required to be carried out during the Construction Period; and
- (b) the options for implementing the proposed Change of Scope and the effect, if any, each such option would have on the costs and time thereof, including a detailed breakdown by work classifications specifying the material and labour costs calculated in accordance with the schedule of rates applicable to the works assigned by the Authority to its contractors, along with the proposed premium/discount on such rates; provided that the cost incurred by the Concessionaire in providing such information shall be reimbursed by the Authority to the extent such cost is certified by the Independent Engineer as reasonable.



16.2.3 Upon receipt of information set forth in Clause 16.2.2, if the Authority decides to proceed with the Change of Scope, it shall convey its preferred option to the Concessionaire, and the Parties shall, with assistance of the Independent Engineer, thereupon make good faith efforts to agree upon the time and costs for implementation thereof. Upon reaching an agreement, the Authority shall issue an order (the "Change of Scope Order") requiring the Concessionaire to proceed with the performance thereof. In the event that the Parties are unable to agree, the Authority may, by issuing a Change of Scope Order, require the Concessionaire to proceed with the performance thereof pending resolution of the Dispute, or carry out the works in accordance with Clause 16.5.

16.2.4 The provisions of this Agreement, insofar as they relate to Construction Works and Tests, shall apply mutatis mutandis to the works undertaken by the Concessionaire under this Article 16.

16.3 Payment for Change of Scope

Within 7 (seven) days of issuing a Change of Scope Order, the Authority shall make an advance payment to the Concessionaire in a sum equal to 20% (twenty per cent) of the cost of Change of Scope as agreed hereunder, and in the event of a Dispute, 20% (twenty per cent) of the cost assessed by the Independent Engineer. The Concessionaire shall, after commencement of work, present to the Authority bills for payment in respect of the works in progress or completed works, as the case may be, supported by such Documentation as is reasonably sufficient for the Authority to determine the accuracy thereof. Within 30 (thirty) days of receipt of such bills, the Authority shall disburse to the Concessionaire such amounts as are certified by the Independent Engineer as reasonable and after making a proportionate deduction for the advance payment made hereunder, and in the event of any Dispute, final adjustments thereto shall be made under and in accordance with the Dispute Resolution Procedure.

16.4 Restrictions on certain works

16.4.1 Notwithstanding anything to the contrary contained in this Article 16, but subject to the provisions of Clause 16.4.2, the Authority shall not require the Concessionaire to undertake any works or services if such works or services are likely to delay completion of the Project by the Scheduled Completion Date; provided that in the event that the Authority considers such works or services to be essential, it may issue a Change of Scope Order, subject to the condition that the works forming part of or affected by such Change of Scope Order shall not be reckoned for purposes of determining completion of the Project and issuing the Provisional Certificate.

16.4.2 Notwithstanding anything to the contrary contained in this Article 16, the Concessionaire shall be entitled to nullify any Change of Scope Order if it causes the cumulative costs relating to all the Change of Scope Orders to exceed 10% (ten per cent) of the Bid Project Cost in any continuous period of 3 (three) years immediately preceding the date of such Change of Scope Order or if such cumulative costs exceed 25% (twenty five per cent) of the Bid Project Cost at any time during the Concession Period.

16.5 Power of the Authority to undertake works

16.5.1 Notwithstanding anything to the contrary contained in Clauses 16.1.1 and 16.3, the Authority may, after giving notice to the Concessionaire and considering its reply thereto, award any works or services, contemplated under Clause 16.1.1, to any person on the basis of open competitive bidding; provided that the Concessionaire shall have the option of matching the first ranked bid in terms of the selection criteria, subject to payment of 2% (two per cent) of the bid amount to the Authority, and thereupon securing the award of such works or services. For the avoidance of doubt, it is agreed that the Concessionaire shall be entitled to exercise such option only if it has participated in the bidding process and its bid does not exceed the first ranked bid by more than 10% (ten per cent) thereof. It is also agreed that the Concessionaire shall provide access, assistance and cooperation to the person who undertakes the works or services hereunder².

16.5.2 The works undertaken in accordance with this Clause 16.5 shall conform to the Specifications and Standards and shall be carried out in a manner that minimizes disruption in operation of the Project. The provisions of this Agreement, insofar as they relate to Construction Works and Tests, shall apply mutatis mutandis to the works carried out under this Clause 16.5.

16.6 Reduction in Scope of the Project

16.6.1 If the Concessionaire shall have failed to complete any Construction Works on account of Force Majeure or for reasons attributable to the Authority or under the provision of Clause 10.3.4 of this Agreement, the Authority shall follow the following process for calculation of total cost of reduced Scope

- I. On direction by the Authority, the Independent Engineer to assess the civil cost of the reduced Scope, as per the schedule of rates applicable on the Bid Due Date.
- II. The civil cost of the reduced Scope shall be multiplied by the 1.04 to arrive at the estimated cost of reduced Scope.
- III. The estimated cost of reduced Scope shall then be multiplied by the ratio of Bid Project Cost to Estimated Project Cost to arrive at the Total Cost of Reduced Scope.

On or before a Payment Milestone immediately succeeding the date of finalization of such Reduction in Scope, the Bid Project Cost shall be reduced by the Total Cost of Reduced Scope and all payments made or to be made to the Concessionaire shall be suitably adjusted and recoveries, if any, shall be made from the payment to be released on that Payment Milestone immediately succeeding the date of finalization of Reduction in Scope.



²The Authority shall transfer 75% (seventy five per cent) of the amount so received to the first ranked bidder whose bid shall have been matched by the Concessionaire.



For the avoidance of doubt, it is agreed that upon the Reduction of Scope and revision of Bid Project Cost, all references to Bid Project Cost would mean the revised Bid Project Cost and all the payments would be calculated as per the revised Bid Project Cost.

16.6.2 For determining the obligations of the Concessionaire under this Clause 16.6, the provisions of Clauses 16.1, 16.2 and 16.4 shall apply mutatis mutandis, and upon issue of Change of Scope Order by the Authority hereunder, the Concessionaire shall pay forthwith the sum specified therein.

16.7 Effect of Change in Scope on the O&M Costs

Pursuant to the provisions of this Article 16, if the Change in Scope leads to a reduction or increase in the length of the Project Highway, the O&M Payments as provided in Clause 23.7 shall be reduced or increased in proportion to the reduction or increase in the length of the Project Highway.



ARTICLE 17

OPERATION AND MAINTENANCE

17.1 O&M obligations of the Concessionaire

17.1.1 During the Operation Period, the Concessionaire shall operate and maintain the Project in accordance with this Agreement either by itself, or through the O&M Contractor and if required, modify, repair or otherwise make improvements to the Project to comply with the provisions of this Agreement, Applicable Laws and Applicable Permits, and conform to Specifications and Standards and Good Industry Practice. The obligations of the Concessionaire hereunder shall include:

- (a) Procuring and ensuring safe, smooth and uninterrupted use of the Project, including prevention of loss or damage thereto, during normal operating conditions;
- (b) Minimizing disruption in the event of accidents or other incidents affecting the safety and use of the Project by providing a rapid and effective response and maintaining liaison with emergency services of the State;
- (c) Carrying out periodic preventive maintenance of the Project;
- (d) undertaking routine maintenance including prompt repairs of potholes, cracks, joints, drains, embankments, structures, markings, lighting, signage and other control devices;
- (e) Undertaking major maintenance such as resurfacing, repairs to structures, and repairs and refurbishment of system and equipment;
- (f) Preventing, with the assistance of concerned law enforcement agencies, any unauthorized use of the Project;
- (g) Preventing, with the assistance of the concerned law enforcement agencies, any encroachments on, or unauthorized entry to the Project;
- (h) Protection of the environment and provision of equipment and materials thereof;
- (i) operation and maintenance of all communication, control and administrative systems necessary for the efficient operation of the Project and for providing safe, smooth and uninterrupted use of the Project;
- (j) Deleted
- (k) Maintaining a public relations unit to interface with and attend to suggestions from the Users, government agencies, media and other agencies; and
- (l) Complying with Safety Requirements in accordance with Article 18.

17.1.2 The Concessionaire shall remove promptly from the Project all surplus construction machinery and materials, waste materials (including hazardous materials and waste



water), rubbish and other debris (including, without limitation, accident debris) and keep the Project in a clean, tidy and orderly condition, and in conformity with Applicable Laws, Applicable Permits and Good Industry Practice. For the avoidance of doubt, it is agreed that the debris and material excavated shall be carried to and deposited at the location identified by the Authority and/or Independent Engineer.

17.1.3 The Concessionaire shall maintain, in conformity with Good Industry Practice, all stretches of approach roads.

17.2 Maintenance Requirements

The Concessionaire shall procure that at all times during the Operation Period; the Project conforms to the maintenance requirements set forth in Schedule-K (the "Maintenance Requirements").

17.3 Maintenance Manual

17.3.1 No later than 90 (ninety) days prior to the Scheduled Completion Date, the Concessionaire shall, in consultation with the Independent Engineer, evolve a repair and maintenance manual (the "Maintenance Manual") for the regular and preventive maintenance of the Project in conformity with the Specifications and Standards, Maintenance Requirements, Safety Requirements and Good Industry Practice, and shall provide 5 (five) copies thereof to the Authority and 2 (two) copies to the Independent Engineer. The Maintenance Manual shall be revised and updated once every 3 (three) years and the provisions of this Clause shall apply, mutatis mutandis, to such revision.

17.3.2 Without prejudice to the provision of Clause 17.3.1, the Maintenance Manual shall, in particular, include provisions for maintenance of Project Assets and shall provide for life cycle maintenance, routine maintenance and reactive maintenance which may be reasonably necessary for maintenance and repair of The Project Assets, including replacement thereof, such that their overall condition conforms to Good Industry Practice.

17.4 Maintenance Program

17.4.1 On or before COD and no later than 45 (forty five) days prior to the beginning of each Accounting Year during the Operation Period, as the case may be, the Concessionaire shall provide to the Authority and the Independent Engineer, its proposed annual program of preventive, urgent and other scheduled maintenance (the "Maintenance Program") to comply with the Maintenance Requirements, Maintenance Manual and Safety Requirements. Such Maintenance Program shall include:

- (a) preventive maintenance schedule;
- (b) arrangements and procedures for carrying out urgent repairs;
- (c) Criteria to be adopted for deciding maintenance needs;
- (d) Intervals and procedures for carrying out inspection of all elements of the Project;
- (e) Intervals at which the Concessionaire shall carry out periodic maintenance;



- (f) Arrangements and procedures for carrying out safety related measures; and
- (g) Intervals for major maintenance works and the scope thereof.

17.4.2 Within 15 (fifteen) days of receipt of the Maintenance Program, the Independent Engineer shall review the same and convey its comments to the Concessionaire with particular reference to its conformity with the Maintenance Requirements, Maintenance Manual and Safety Requirements.

17.4.3 The Concessionaire may modify the Maintenance Program as may be reasonable in the circumstances, and the procedure specified in Clauses 17.4.1 and 17.4.2 shall apply mutatis mutandis to such modifications.

17.5 Safety, breakdowns and accidents

17.5.1 The Concessionaire shall ensure safe conditions for the Users, and in the event of unsafe conditions, closures, diversions, breakdowns and accidents, it shall follow the relevant operating procedures including the setting up of temporary Lights and removal of obstruction and debris without delay. Such procedures shall conform to the provisions of this Agreement, Applicable Laws, Applicable Permits and Good Industry Practice.

17.5.2 The Concessionaire's responsibility for rescue operations on the Project shall be limited to an initial response to any particular incident until such time as the competent authority takes charge and shall include prompt removal of vehicles or debris or any other obstruction, which may endanger or interrupt the use of the Project. For this purpose, it shall maintain and operate a round-the-clock rescue post with equipment in accordance with Good Industry Practice.

17.6 De-commissioning due to Emergency

17.6.1 If, in the reasonable opinion of the Concessionaire, there exists an Emergency which warrants de-commissioning and closure of the whole or any part of the Project, the Concessionaire shall be entitled to de-commission and close the whole or any part of the Project for so long as such Emergency and the consequences thereof warrant; provided that such de-commissioning and particulars thereof shall be notified by the Concessionaire to the Authority Without any delay, and the Concessionaire shall diligently carry out and abide by any reasonable directions that the Authority may give for dealing with such Emergency.

17.6.2 The Concessionaire shall re-commission the Project or the affected part thereof as quickly as practicable after the circumstances leading to its de-commissioning and closure have ceased to exist or have so abated as to enable the Concessionaire to re-commission the Project and shall notify the Authority of the same without any delay.

17.6.3 Any decommissioning or closure of any part of the Project and the re-commissioning thereof shall, as soon as practicable, be brought to the notice of affected persons by means of public announcements/notice.

17.7 Project closure

17.7.1 Save and except as provided in Clause 17.6, the Concessionaire shall not close any part of the Project for undertaking maintenance or repair works not forming part of the

Maintenance Program, except with the prior written approval of the Independent Engineer. Such approval shall be sought by the Concessionaire through a written request to be made to the Independent Engineer, and a copy thereof furnished to the Authority, at least 7 (seven) days before the proposed closure and shall be accompanied by particulars thereof. Within 3 (three) days of receiving such request, the Independent Engineer shall grant permission with such modifications as it may deem reasonable and necessary in conformity with the Maintenance Manual and Maintenance Program and a copy of such permission shall be sent to the Authority.

- 17.7.2 The provisions of Clause 17.7.1 shall not apply to de-commissioning under Clause 17.6.1 or to any closure for a period not exceeding 2 (two) hours in a day at any time of the day and 6 (six) hours in a day at a time specified by the Independent Engineer as off-peak hours when usage of the Project is comparatively lower.
- 17.7.3 Upon receiving the permission pursuant to Clause 17.7.1, the Concessionaire shall be entitled to close the designated part of the Project for the period specified therein, and in the event of any delay in re-opening such part, the Concessionaire shall pay Damages to the Authority calculated at the rate of 0.5 % (zero point Five per cent) of the Performance Security, for each day of delay until that part of the Project has been re-opened for use.

17.8 Damages for breach of maintenance obligations

- 17.8.1 In the event that the Concessionaire fails to repair or rectify any defect or deficiency set forth in the Maintenance Requirements within the period specified therein, it shall be deemed to be in breach of this Agreement and the Authority shall be entitled to recover Damages, to be calculated and paid for each day of delay until the breach is cured, at the higher of (a) 2% (two per cent) of the Performance Security, and (b) 0.1% (zero point one per cent) of the cost of such repair or rectification as estimated by the Independent Engineer. Recovery of such Damages shall be without prejudice to the rights of the Authority under this Agreement, including the right of Termination thereof.
- 17.8.2 The Damages set forth in Clause 17.8.1 may be assessed and specified forthwith by the Independent Engineer; provided that the Authority may, in its discretion, demand a smaller sum as Damages, if in its opinion, the breach has been cured promptly and the Concessionaire is otherwise in compliance with its obligations hereunder. The Concessionaire shall pay such Damages forthwith and in the event that it contests such Damages, the Dispute Resolution Procedure shall apply.

17.9 Authority's right to take remedial measures

- 17.9.1 In the event the Concessionaire does not maintain and/or repair the Project or any part thereof in conformity with the Maintenance Requirements, the Maintenance Manual or the Maintenance Program, as the case may be, and fails to commence remedial works within 15 (fifteen) days of receipt of the O&M Inspection Report or a notice in this behalf from the Authority or the Independent Engineer, as the case may be, the Authority shall, without prejudice to its rights under this Agreement including Termination thereof, be entitled to undertake such remedial measures at the risk and cost of the Concessionaire, and to recover its cost from the Concessionaire. In addition to recovery of the aforesaid cost, a sum equal to 20% (twenty per cent) of such cost shall be paid by the Concessionaire to the Authority as



Damages. For the avoidance of doubt, the right of the Authority under this Clause 17.9.1 shall be without prejudice to its rights and remedies provided under Clause 17.8.

17.9.2 The Authority shall have the right, and the Concessionaire hereby expressly grants to the Authority the right, to recover the costs and Damages specified in Clause 17.9.1 directly from the Escrow Account as if such costs and Damages were O&M Expenses, and for that purpose, the Concessionaire hereby agrees to give irrevocable instructions to the Escrow Bank to make payment from the Escrow Account in accordance with the instructions of the Authority under this Clause 17.9.2 and debit the same to O&M Expenses.

17.10 Overriding powers of the Authority

17.10.1 If in the reasonable opinion of the Authority, the Concessionaire is in material breach of its obligations under this Agreement and, in particular, the Maintenance Requirements, and such breach is causing or likely to cause material hardship or danger to the Users, the Authority may, without prejudice to any of its rights under this Agreement including Termination thereof, by notice require the Concessionaire to take reasonable measures immediately for rectifying or removing such hardship or danger, as the case may be.

17.10.2 In the event that the Concessionaire, upon notice under Clause 17.10.1, fails to rectify or remove any hardship or danger within a reasonable period, the Authority may exercise overriding powers under this Clause 17.10.2 and take over the performance of any or all the obligations of the Concessionaire to the extent deemed necessary by it for rectifying or removing such hardship or danger; provided that the exercise of such overriding powers by the Authority shall be of no greater scope and of no longer duration than is reasonably required hereunder; provided further that any costs and expenses incurred by the Authority in discharge of its obligations hereunder shall be deemed to be O&M Expenses, and the Authority shall be entitled to recover them from the Concessionaire in accordance with the provisions of Clause 17.9 along with the Damages specified therein.

17.10.3 In the event of a national emergency, civil commotion or any other act specified in Clause 28.3, the Authority may take over the performance of any or all the obligations of the Concessionaire to the extent deemed necessary by it, and exercise such control over the Project or give such directions to the Concessionaire as may be deemed necessary; provided that the exercise of such overriding powers by the Authority shall be of no greater scope and of no longer duration than is reasonably required in the circumstances which caused the exercise of such overriding power by the Authority. For the avoidance of doubt, it is agreed that the consequences of such action shall be dealt in accordance with the provisions of Article 28. It is also agreed that the Concessionaire shall comply with such instructions as the Authority may issue in pursuance of the provisions of this Clause 17.10, and shall provide assistance and cooperation to the Authority, on a best effort basis, for performance of its obligations hereunder.

17.11 Restoration of loss or damage to the Project

Save and except as otherwise expressly provided in this Agreement, in the event that the Project or any part thereof suffers any loss or damage during the Concession Period from any cause whatsoever, the Concessionaire shall, at its cost and expense, rectify and



remedy such loss or damage forthwith so that the Project conforms to the provisions of this Agreement.

17.12 Modifications to the Project

The Concessionaire shall not carry out any material modifications to the Project, save and except where such modifications are necessary for the Project to operate in conformity with the Specifications and Standards, Maintenance Requirements, Good Industry Practice and Applicable Laws; provided that the Concessionaire shall notify the Independent Engineer of the proposed modifications along with particulars thereof at least 15 (fifteen) days before commencing work on such modifications and shall reasonably consider any suggestions that the Independent Engineer may make within 15 (fifteen) days of receiving the Concessionaire's proposal. For the avoidance of doubt, all modifications made hereunder shall comply with the Safety Requirements, Specifications and Standards, Applicable Laws and the provisions of this Agreement.

17.13 Excuse from performance of obligations

The Concessionaire shall not be considered in breach of its obligations under this Agreement if any part of the Project is not available to Users on account of any of the following for the duration thereof:

- (a) an event of Force Majeure;
- (b) measures taken to ensure the safe use of the Project except when unsafe conditions occurred because of failure of the Concessionaire to perform its obligations under this Agreement; or
- (c) compliance with a request from the Authority or the directions of any Government Instrumentality, the effect of which is to close all or any part of the Project:

Provided, that any such non-availability and particulars thereof shall be notified by the Concessionaire to the Authority and the Independent Engineer without any delay;

Provided further that the Concessionaire shall keep all unaffected parts of the Project open to Users, provided they can be operated safely.

17.14 Deleted

17.15 Installation and operation of CCTV

The Concessionaire shall install and operate a closed circuit television system to monitor such parts of the Project as may be necessary and expedient for a safe, secure and smooth operation thereof.

17.16 Advertising on the Site

The Concessionaire shall not undertake or permit any form of commercial advertising, display or hoarding at any place on the Site.



ARTICLE 18

SAFETY REQUIREMENTS

18.1 Safety Requirements

- 18.1.1 The Concessionaire shall comply with the provisions of this Agreement, Applicable Laws and Applicable Permits and conform to Good Industry Practice for securing the safety of the Users. In particular, the Concessionaire shall develop, implement and administer a surveillance and safety program for providing a safe environment on or about the Project, and shall comply with the safety requirements set forth in Schedule-L (the "Safety Requirements").
- 18.1.2 The Authority shall appoint an experienced and qualified firm or organization (the "Safety Consultant") for carrying out safety audit of the Project in accordance with the Safety Requirements, and shall take all other actions necessary for securing compliance with the Safety Requirements.

18.2 Expenditure on Safety Requirements

All costs and expenses arising out of or relating to Safety Requirements shall be borne by the Concessionaire to the extent such costs and expenses form part of the works and services included in the Scope of the Project, and works and services, if any, not forming part of the Scope of the Project shall be undertaken and funded in accordance with the provisions of Article 16.



ARTICLE 19

MONITORING OF OPERATION AND MAINTENANCE

19.1 Monthly status reports

19.1.1 During the Operation Period, the Concessionaire shall, no later than 7 (seven) days after the close of each month, furnish to the Authority and the Independent Engineer a monthly report stating in reasonable detail the condition of the Project including its compliance or otherwise with the Maintenance Requirements, Maintenance Manual, Maintenance Program and Safety Requirements, and shall promptly give such other relevant information as may be required by the Independent Engineer or the Authority. In particular, such report shall separately identify and state in reasonable detail the defects and deficiencies that require rectification.

19.1.2 During the Operation Period, the Concessionaire shall, no later than 10 (ten) days after the close of each month, furnish a monthly management report which shall include a summary of:

- (a) key performance indicators achieved in the month, along with an analysis of reasons for failures, if any, and proposals to remedy the same;
- (b) key operational hurdles and deliverables in the succeeding month along with strategies for addressing the same and for otherwise improving the Project's operational performance; and
- (c) key financial parameters for the month, as benchmarked against the monthly budget and the reasons for shortfall, if any, and proposals to remedy the same.

19.2 Inspection

The Independent Engineer shall inspect the Project at least once a month. It shall make a report of such inspection (the "O&M Inspection Report") stating in reasonable detail the defects or deficiencies, if any, with particular reference to the Maintenance Requirements, Maintenance Manual, the Maintenance Program and Safety Requirements, and send a copy thereof to the Authority and the Concessionaire within 7 (seven) days of such inspection.

19.3 Tests

For determining that the Project conforms to the Maintenance Requirements, the Independent Engineer shall require the Concessionaire to carry out, or cause to be carried out, tests specified by it in accordance with Good Industry Practice. The Concessionaire shall, with due diligence, carry out or cause to be carried out all such tests in accordance with the instructions of the Independent Engineer and furnish the results of such tests forthwith to the Independent Engineer. One half of the costs incurred on such tests, and to the extent certified by the Independent Engineer as reasonable, shall be reimbursed by the Authority to the Concessionaire.

19.4 Remedial measures

- 19.4.1 The Concessionaire shall repair or rectify the defects or deficiencies, if any, set forth in the O&M Inspection Report or in the test results referred to in Clause and furnish a report in respect thereof to the Independent Engineer and the Authority within 15 (fifteen) days of receiving the O&M Inspection Report or the test results, as the case may be; provided that where the remedying of such defects or deficiencies is likely to take more than 15 (fifteen) days, the Concessionaire shall submit progress reports of the repair works once every week until such works are completed in conformity with this Agreement.
- 19.4.2 The Independent Engineer shall require the Concessionaire to carry out or cause to be carried out tests, at its own cost, to determine that such remedial measures have brought the Project into compliance with the Maintenance Requirements and the procedure set forth in this Clause 19.4 shall be repeated until the Project conforms to the Maintenance Requirements. In the event that remedial measures are not completed by the Concessionaire in conformity with the provisions of this Agreement, the Authority shall be entitled to recover Damages from the Concessionaire under and in accordance with the provisions of Clause 17.8.

19.5 Reports of unusual occurrence

The Concessionaire shall, prior to the close of each day, send to the Authority and the Independent Engineer, by facsimile or e-mail, a report stating accidents and unusual occurrences on the Project relating to the safety and security of the Users and the Project. A weekly and monthly summary of such reports shall also be sent within 3 (three) days of the closing of each week and month, as the case maybe. For the purposes of this Clause 19.5, accidents and unusual occurrences on the Project shall include:

- (a) Death or injury to any person;
- (b) Damaged or dislodged fixed equipment;
- (c) Any damage or obstruction on the Project, which results in slow down of the services being provided by the Concessionaire;
- (d) Disablement of any equipment during operation;
- (e) Communication failure affecting the operation of the Project;
- (f) Smoke or fire;
- (g) Flooding of the Project; and
- (h) Such other relevant information as may be required by the Authority or the Independent Engineer.



ARTICLE 20

REGULATION AND MANAGEMENT

20.1 Traffic regulation by the Concessionaire

The Concessionaire shall regulate traffic on the Project in accordance with Applicable Laws, and subject to the supervision and control of the State authorities or a substitute thereof empowered in this behalf under Applicable Laws.

20.2 Police assistance

For regulating the use of Project in accordance with Applicable Laws and this Agreement, the Authority shall assist the Concessionaire in procuring police assistance from the State Police Department or a substitute thereof. The police assistance shall include setting up of a traffic aid post (the "Traffic Aid Post") at each of the Toll Plazas with a mobile Police squad for round-the-clock patrolling of the Project.

20.3 Buildings for Traffic Aid Posts

The Concessionaire shall, in accordance with the type designs prescribed for such police outpost buildings by the State Government or a substitute thereof, construct at its own cost and expense, buildings not exceeding 25 (twenty five) square metres of plinth area, for each of the Traffic Aid Posts, and hand them over to the Authority no later than 60 (sixty) days prior to the Scheduled Completion Date. The Traffic Aid Posts shall be deemed to be part of the Site and shall vest in the Authority.

20.4 Medical Aid Posts

For providing emergency medical aid during- the Operation Period, as set forth in this Agreement, the Concessionaire shall assist the State Government or a substitute thereof to be designated by the Authority in setting up and operating a medical aid post (the "Medical Aid Post") at the Site for victims of accidents on the Project at each of the Toll Plazas with round-the-clock ambulance services for victims of accidents on the Project Highway.

20.5 Buildings for Medical Aid Posts

The Concessionaire shall, at its cost and in accordance with the type designs prescribed for such buildings by the State Medical Department (or a substitute thereof to be designated by the Authority), construct an aid post building and 2 (two) residential quarters, and hand them over to the Authority, no later than 30 (thirty) days prior to Scheduled Completion Date. The Medical Aid Post(s) shall be deemed to be part of the Site and shall vest in the Authority.

20.6 Computer systems and network

The Concessionaire shall install, operate and maintain a computer system with round-the-clock connections to the networks of the Authority and other related entities for



exchange of data and information useful or necessary for efficient and transparent regulation and management of traffic. For this purpose, it shall follow such protocol for Electronic Data Interchange (the "EDI") as the Authority may specify.

20.7 Recurring expenditure on Police assistance

On or before the Scheduled Four-Laning Date, the Concessionaire shall provide to the State Police Department or a substitute thereof one Jeep or similar vehicle in good working condition along with chauffeurs for round-the-clock patrolling as set forth in Clause 20.2 and shall meet the operating costs of such vehicle including the salaries and allowances of the chauffeurs.

20.8 Recurring expenditure on Medical Aid Posts

On or before COD, the Concessionaire shall provide to the State Medical Department or a substitute thereof to be designated by the Authority one ambulance in good working condition along with chauffeurs for round-the-clock ambulance services as set forth in Clause 20.4 and meet the operating costs of such ambulance including the salaries and allowances of the chauffeurs. The Concessionaire shall also reimburse to the State Medical Department (or a substitute thereof to be designated by the Authority) the actual expenditure incurred by it in each Accounting Year on the medical equipment, and the pay and allowances of up to 2 (two) medical personnel deployed exclusively for the Medical Aid Posts and ambulance, and shall maintain the Medical Aid Post buildings in accordance with Good Industry Practice. For the avoidance of doubt, it is agreed that the Concessionaire shall not be liable for any other expenditure incurred by the State Medical Department or a substitute thereof to be designated by the Authority.



ARTICLE 21

INDEPENDENT ENGINEER

21.1 Appointment of Independent Engineer

The Authority shall appoint a consulting engineering firm substantially in accordance with the selection criteria set forth in Schedule-M, to be the independent consultant under this Agreement (the "Independent Engineer"). The appointment shall be made no later than 60 (sixty) days from the date of this Agreement and shall be for a period of Construction Period plus six (6) months). On expiry or termination of the aforesaid appointment, the Authority shall appoint an Independent Engineer for a further term of 3 (three) years in accordance with the provisions of Schedule-M, and such procedure shall be repeated after expiry of each appointment.

21.2 Duties and functions

21.2.1 The Independent Engineer shall discharge its duties and functions substantially in accordance with the terms of reference set forth in Schedule-N.

21.2.2 The Independent Engineer shall submit regular periodic reports (at least once every month) to the Authority in respect of its duties and functions set forth in Schedule-N.

21.2.3 A true copy of all communications sent by the Authority to the Independent Engineer and by the Independent Engineer to the Authority shall be sent forthwith by the Independent Engineer to the Concessionaire.

21.2.4 A true copy of all communications sent by the Independent Engineer to the Concessionaire and by the Concessionaire to the Independent Engineer shall be sent forthwith by the Independent Engineer to the Authority.

21.3 Remuneration

The remuneration, cost and expenses of the Independent Engineer shall be paid by the Authority and subject to the limits set forth in Schedule-M, one-half of such remuneration, cost and expenses shall be reimbursed by the Concessionaire to the Authority within 15 (fifteen) days of receiving a statement of expenditure from the Authority.

21.4 Termination of appointment

21.4.1 The Authority may, in its discretion, terminate the appointment of the Independent Engineer at any time, but only after appointment of another Independent Engineer in accordance with Clause 21.1.

21.4.2 If the Concessionaire has reason to believe that the Independent Engineer is not discharging its duties and functions in a fair, efficient and diligent manner, it may make a written representation to the Authority and seek termination of the appointment of the Independent Engineer. Upon receipt of such representation, the Authority shall hold a tripartite meeting with the Concessionaire and Independent Engineer for an amicable resolution of the Dispute, and if any difference or disagreement between the Authority



and the Concessionaire remains unresolved, the Dispute shall be settled in accordance with the Dispute Resolution Procedure. In the event that the appointment of the Independent Engineer is terminated hereunder, the Authority shall appoint forthwith another Independent Engineer in accordance with Clause 21.1.

21.5 Authorized signatories

The Authority shall require the Independent Engineer to designate and notify to the Authority and the Concessionaire up to 2 (two) persons employed in its firm to sign for and on behalf of the Independent Engineer, and any communication or document required to be signed by the Independent Engineer shall be valid and effective only if signed by any of the designated persons; provided that the Independent Engineer may, by notice in writing, substitute any of the designated persons by any of its employees.

21.6 Dispute resolution

If either Party disputes any advice, instruction, decision, direction or award of the Independent Engineer, or, as the case may be, the assertion or failure to assert jurisdiction, the Dispute shall be resolved in accordance with the Dispute Resolution Procedure.

21.7 Interim arrangement

In the event that the Authority does not appoint an Independent Engineer, or the Independent Engineer so appointed has relinquished its functions or defaulted in discharge thereof, the Authority may, in the interim, designate and authorize any person to discharge the functions of the Independent Engineer in accordance with the provisions of this Agreement, save and except that such person shall not exercise any functions relating to review, comment, approval or inspection as specified in this Agreement for and in respect of the Independent Engineer, and such functions shall be discharged as and when an Independent Engineer is appointed in accordance with the provisions of this Agreement. Provided, however, that nothing contained in this Clause 21.7 shall in any manner restrict the rights of the Authority to enforce compliance of the provisions of this Agreement.



Part IV

Financial Covenants



ARTICLE 22

FINANCIAL CLOSE

22.1 Financial Close

22.1.1 The Concessionaire hereby agrees and undertakes that it shall achieve Financial Close for an amount not lower than either:

i. Total Project Cost; or

ii. 10% less than (Estimated Project Cost minus 40% Bid Project Cost).

within 150 (one hundred and fifty) days from the date of this Agreement. In the event of delay in achieving the Financial Close, the Concessionaire shall be entitled to a further period not exceeding 120 (one hundred twenty) days, subject to payment of Damages to the Authority in a sum calculated at the rate of 0.05% (zero point zero five per cent) of the Performance Security for each day of delay, provided that the Damages specified herein shall be payable every week in advance and the period beyond the said 150 (one hundred and fifty) days shall be granted only to the extent of Damages so paid. In the event of delay in achieving the Financial Close beyond 270 (two hundred and seventy) days from the date of this Agreement, the Concessionaire shall be entitled to a further period not exceeding 95 (ninety five) days, subject to payment of Damages to the Authority in a sum calculated at the rate of 0.1% (zero point one per cent) of the Performance Security for each day of delay, provided that the Damages specified herein shall be payable every week in advance and the period beyond the said 270 (two hundred and seventy) days shall be granted only to the extent of Damages so paid; provided further that no Damages shall be payable if such delay in Financial Close has occurred due to Force Majeure. For the avoidance of doubt, the Damages payable hereunder by the Concessionaire shall be in addition to the Damages, if any, due and payable under the provisions of Clause 4.3.

22.1.2 The Concessionaire shall, upon occurrence of Financial Close, notify the Authority forthwith, and shall have provided to the Authority, at least 2 (two) days prior to the Financial Close, 3 (three) true copies of the Financial Package and the Financial Model, duly attested by a Director of the Concessionaire, along with 3 (three) soft copies of the Financial Model in MS Excel version or any substitute thereof, which is acceptable to the Senior Lenders.

22.2 Termination due to failure to achieve Financial Close

22.2.1 Notwithstanding anything to the contrary contained in this Agreement, but subject to Clause 28.6.1, in the event that Financial Close does not occur, for any reason whatsoever, within the period set forth in Clause 22.1.1 or the extended period provided thereunder, all rights, privileges, claims and entitlements of the Concessionaire under or arising out of this Agreement shall be deemed to have been waived by, and to have ceased with the concurrence of the Concessionaire, and the Concession Agreement shall be deemed to have been terminated by mutual agreement of the Parties.

22.2.2 Upon Termination under Clause 22.2.1, the Authority shall be entitled to **suspend the bidder for participation in the tendering process for the work of MoRTH/NHA/NHIDCL**

Four laning of NH-163 from Hyderabad (ORR Appa Junction) (Design Km 14.000/Existing Km 14.000) to Manneguda (Design Km 60.405/Existing Km 59.500) (Design Length = 46.405 Km) in the State of Telangana under NH(O) on Hybrid Annuity Mode

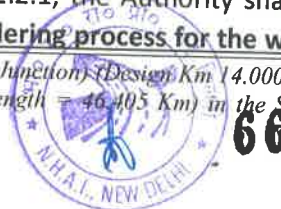

PUBLIC PRIVATE PARTNERSHIP IN HYBRID ANNUITY PROJECTS

and work under other Centrally Sponsored Schemes for a period of One Year from the bid due date of this work; provided, however, that if Financial Close has not occurred due to Force Majeure, it shall, upon Termination, not suspend the bidder for participation in the tendering process for the work of MoRTH/NHAI/NHIDCL and work under other Centrally Sponsored Schemes for a period of One Year from the bid due date of this work or release the Performance Security, as the case may be. For the avoidance of doubt, it is expressly agreed that if the **Performance Security has been submitted by the Concessionaire**, the Authority shall be entitled to encash there from an amount equal to the **1% of Estimated Project Cost mentioned in the RFP and appropriate the proceeds thereof as Damages**



ARTICLE 23

PAYMENT OF BID PROJECT COST

23.1 Bid Project Cost

The Parties expressly agree that the cost of construction of the Project, as on the Bid Date, which is due and payable by the Authority to the Concessionaire, shall be deemed to be Rs. 785 Crore (Rupees Seven Hundred Eighty Five Crores Only) (The " **Bid Project Cost** ")[£]. The Parties further agree that the Bid Project Cost specified hereinabove for payment to the Concessionaire shall be inclusive of the cost of construction, interest during construction, working capital, physical contingencies and all other costs, expenses and charges for and in respect of construction of the Project, save and except any additional costs arising on account of variation in Price Index, Change of Scope, Change in Law, Force Majeure or breach of this Agreement, which costs shall be due and payable to the Concessionaire in accordance with the provisions of the Agreement. The Bid Project Cost shall be exclusive of GST, which shall be paid to the Concessionaire by the Authority at the applicable rates. For the avoidance of doubt, the Bid Project Cost specified herein represents the amount due and payable by the Authority to the Concessionaire and may be less than, equal to, or more than the Estimated Project Cost.

23.2 Adjusted Bid Project Cost

- 23.2.1 The Bid Project Cost specified in Clause 23.1 shall be revised from time to time in accordance with the provisions of this Clause 23.2 to reflect the variation in Price Index occurring after the Reference Index Date immediately preceding the Bid Date.
- 23.2.2 The Bid Project Cost adjusted for variation between the Price Index occurring between the Reference Index Date preceding the Bid Date and the Reference Index Date immediately preceding the Appointed Date shall be deemed to be the Bid Project Cost at commencement of construction.
- 23.2.3 For every month occurring after the Appointed Date, the Authority shall compute the variation in Price Index occurring between the Reference Index Date preceding the Bid Date and the Reference Index Date preceding the date of Invoice, and shall express the latter as a multiple of the former (the " **Price Index Multiple** "). All Invoices to be submitted by the Concessionaire to the Authority for and in respect of the Construction Period shall be the product of the relevant proportion of the Bid Project Cost and the Price Index Multiple applicable on the date of Invoice. For the avoidance of doubt and by way of illustration, if (a) the Price Index on the Reference Index Date preceding the Bid Date, say January 31, 2016, is 200 (two hundred); (b) the Invoice is submitted on October 15, 2017; and (c) the Price Index as on September 30, 2017 is 210 (two hundred and ten), then the Price Index Multiple for determination of the amount due in respect of such Invoice shall be 1.05 (one point zero five).

[£]Bid Project Cost shall be the amount specified in the Bid of the selected Bidder.



23.3 Payment of Bid Project Cost

- 23.3.1 40% (forty per cent) of the Bid Project Cost , adjusted for the Price Index Multiple, shall be due and payable to the Concessionaire in 10 (ten) equal installments of 4% (four per cent) each during the Construction Period in accordance with the provisions of Clause 23.4.
- 23.3.2 The remaining Bid Project Cost, adjusted for the Price Index Multiple, shall be due and payable in 30 (thirty) biannual installments commencing from the 180th (one hundred and eightieth) day of COD in accordance with the provisions of Clause 23.6.

23.4 Payment during Construction Period

Upon receiving a report from the Independent Engineer certifying the achievement of the below mentioned Payment Milestones³, the Authority shall disburse, within 15 (fifteen) days of the receipt of each such report, an installment equal to 4% (four per cent) of the Bid Project Cost, adjusted for the Price Index Multiple as applicable on the Reference Index Date preceding the date of that report.

For the purpose of this Clause 23.4, the Payment Milestone for release of payment during Construction Period shall be as under:

- a) I (first) Payment Milestone - On achievement of 5% Physical Progress
- b) II (second) Payment Milestone - On achievement of 10% % Physical Progress
- c) III (third) Payment Milestone – On achievement of 20% Physical Progress
- d) IV (fourth) Payment Milestone - On achievement of 30% Physical Progress
- e) V (fifth) Payment Milestone – On achievement of 40% Physical Progress
- f) VI (sixth) Payment Milestone – On achievement of 50% Physical Progress
- g) VII (seventh) Payment Milestone – On achievement of 60% Physical Progress
- h) VIII (eighth) Payment Milestone – On achievement of 70% Physical Progress
- i) IX (nineth) Payment Milestone – On achievement of 80% Physical Progress
- j) X (tenth) Payment Milestone – On achievement of 90% Physical Progress

Provided that in case of Change of Scope, the Physical Progress shall be recalculated to account for the changed scope.

23.5 Bonus on early completion

In the event that the Concessionaire shall achieve COD on or more than 30 (thirty) days prior to the Scheduled Completion Date, the Authority shall pay to the Concessionaire a bonus equal to 0.5% (Zero point five per cent) of 60 % (Sixty per cent) of the Bid Project Cost for the first 30 (thirty) days by which COD shall precede the Scheduled Completion Date and thereafter the said bonus shall be calculated on the pro-rata basis for each day preceding the said 30 (thirty) days period. The Bonus shall be due and payable to the Concessionaire alongwith the 1st(first) Annuity Payment.

³ Independent Engineer, during finalization of design, shall upfront decide weightages of all the items in due consultation with the Authority responsible for making payments and recommended percentage physical progress achievements based on the above decided weightages for the entire construction period. The weightages shall be fixed as per format in Annexure – I of Schedule G of this Agreement.



23.6 Annuity Payments during Operation Period

23.6.1 The (the "Completion Cost" shall be the summation of A, B, C, D, E, F, G, H, I, J and K below:

- A. 5% of the Bid Project Cost adjusted for the Price Index Multiple as applicable on the Reference Index Date preceding the date of report confirming 5% Physical Progress.
- B. Another 5% of the Bid Project Cost adjusted for the Price Index Multiple as applicable on the Reference Index Date preceding the date of report confirming 10% Physical Progress.
- C. Another 10% of the Bid Project Cost adjusted for the Price Index Multiple as applicable on the Reference Index Date preceding the date of report confirming 20% Physical Progress.
- D. Another 10% of the Bid Project Cost adjusted for the Price Index Multiple as applicable on the Reference Index Date preceding the date of report confirming 30% Physical Progress.
- E. Another 10% of the Bid Project Cost adjusted for the Price Index Multiple as applicable on the Reference Index Date preceding the date of report confirming 40% Physical Progress.
- F. Another 10% of the Bid Project Cost adjusted for the Price Index Multiple as applicable on the Reference Index Date preceding the date of report confirming 50% Physical Progress.
- G. Another 10% of the Bid Project Cost adjusted for the Price Index Multiple as applicable on the Reference Index Date preceding the date of report confirming 60% Physical Progress.
- H. Another 10% of the Bid Project Cost adjusted for the Price Index Multiple as applicable on the Reference Index Date preceding the date of report confirming 70% Physical Progress.
- I. Another 10% of the Bid Project Cost adjusted for the Price Index Multiple as applicable on the Reference Index Date preceding the date of report confirming 80% Physical Progress.
- J. Another 10% of the Bid Project Cost adjusted for the Price Index Multiple as applicable on the Reference Index Date preceding the date of report confirming 90% Physical Progress.
- K. Another 10% of the Bid Project Cost adjusted for the Price Index Multiple as applicable on the Reference Index Date preceding the COD.

The Parties acknowledge and agree that the Authority has paid a portion of the Completion Cost as payments during Construction Period pursuant to Clause 23.4 of this Agreement. The balance Completion Cost remaining shall be due and payable during the Operation Period in accordance with the provisions of Clause 23.6.2.



PUBLIC PRIVATE PARTNERSHIP IN HYBRID ANNUITY PROJECTS

23.6.2 The Completion Cost remaining to be paid in pursuance of the provisions of Clause 23.6.1 shall be due and payable in biannual installments over a period of 15 (fifteen) years commencing from COD, (the “Annuity Payments”). The 1st (first) installment of Annuity Payments shall be due and payable within 15 (fifteen) days of the 180th(one hundred and eightieth) day of COD and the remaining installments shall be due and payable within 15 (fifteen) days of completion of each of the successive six months (“the Annuity Payment Date”). For the avoidance of doubt, the last Annuity Payment Date would be adjusted to in such a way that it falls at the end of the Operations Period.

23.6.3 Each of the Annuity Payments due and payable during the years following the COD shall be as under:

Annuity following the COD	Percentage of Completion Cost remaining to be paid on COD
1st Annuity	2.10%
2nd Annuity	2.17%
3rd Annuity	2.24%
4th Annuity	2.31%
5th Annuity	2.38%
6th Annuity	2.45%
7th Annuity	2.52%
8th Annuity	2.60%
9th Annuity	2.68%
10th Annuity	2.76%
11th Annuity	2.84%
12th Annuity	2.93%
13th Annuity	3.02%
14th Annuity	3.11%
15th Annuity	3.20%
16th Annuity	3.30%
17th Annuity	3.40%
18th Annuity	3.50%
19th Annuity	3.61%
20th Annuity	3.72%
21st Annuity	3.83%
22nd Annuity	3.94%
23rd Annuity	4.06%
24th Annuity	4.18%
25th Annuity	4.25%
26th Annuity	4.25%
27th Annuity	4.44%
28th Annuity	4.71%
29th Annuity	4.75%
30th Annuity	4.75%

Each of the biannual installments payable hereunder shall be paid along with interest as specified in Clause 23.6.4.



PUBLIC PRIVATE PARTNERSHIP IN HYBRID ANNUITY PROJECTS

23.6.4 Interest shall be due and payable on the reducing balance of Completion Cost at an interest rate equal to the **average of one year MCLR of top 5 Scheduled Commercial Banks⁴ plus 1.25%**. Such interest shall be due and payable biannually along with each installment specified in Clause 23.6.3. For the avoidance of doubt and by way of illustration, the Parties agree that interest on the Completion Cost remaining to be paid, calculated from COD and until the 180th (one hundred and eightieth) day of COD, shall be due and payable to the Concessionaire along with the first Annuity Payment and interest on ****5% (** per cent)** of the Percentage of Completion Cost remaining to be paid on COD, calculated from first Annuity payment date and until the 1st (first) anniversary of COD, shall be due and payable along with the second Annuity Payment due and payable under this Agreement. The Parties further agree that interest shall be calculated based on the number of days a particular **average of one year MCLR of top 5 Scheduled Commercial Banks** was applicable during the period of calculation. For the purpose of illustration, assuming that the balance capital cost remaining to be paid is Rs 100 crores on the 1st Annuity Payment Date, the applicable **average of one year MCLR of top 5 Scheduled Commercial Banks** for the first 75 days is 8% and thereafter it is revised to 7.5% and remains unchanged till the 2nd Annuity Payment Date, the interest would be calculated as $((100*9.25\%*75)/365)+((100*8.75\%*105)/365)$. For the avoidance of doubt⁶, the Interest would be calculated on simple interest basis and no compounding of the same would be undertaken.

23.7 O&M Payments

23.7.1 The Parties acknowledge and agree that all O&M Expenses shall be borne by the Concessionaire and in lieu thereof; a lump sum financial support in the form of biannual payments shall be due and payable by the Authority, which shall be computed on Rs. 2.00 Crore (Rupees Two Crore Only) (the "**First Year O&M Cost**")⁵, + GST at the applicable rates in accordance with the provisions of this Clause 23.7 (the "**O&M Payments**"). The Parties further acknowledge and agree that any O&M Expenses in excess of the O&M Payments shall be borne solely by the Concessionaire, save and except as expressly provided in this Agreement. For avoidance of doubt it is clarified that the O&M Payments will be subject to any Change in Scope of the Project of the Concessionaire under Article 16 of this Agreement.

23.7.2 Subject to the Provisions of Clause 23.7.3, the O&M Payments due and payable to the Concessionaire shall be paid in 2 (two) equal biannual installments and disbursed by the Authority together with the corresponding installments of Annuity Payments.

⁴ The authority shall declare the list of Top 5 Scheduled Commercial Banks on 1st September every calendar year based on the balance sheet size as declared in their annual reports. The 1 year MCLR of the top 5 scheduled commercial banks shall be taken at the start of every quarter.

⁵ To be finalized on the basis of the outstanding Completion Cost Annuity pursuant to the payment of 1st Annuity as provided in the Annuity payment schedule in Clause 23.6.3

⁶ Assuming that the total number of days between 1st Annuity payment date and 2nd Annuity date are 180. In case the number of days are different the calculation may be appropriately changed

⁵ First Year O&M Cost shall be the amount specified in the Bid of the selected Bidder.



23.7.3 Each installment of O&M Payment shall be the product of the amount determined in accordance with Clause 23.7.1 and the Price Index Multiple on the Reference Index Date preceding the due date of payment thereof. For the avoidance of doubt and by way of illustration, if (i) the First Year O&M Cost is Rs.1Cr. (Rupees one crore); (ii) the O&M Payment is to be determined for the 2nd (second) year of the Operation Period; (iii) the Price Index on the Reference Index Date preceding the Bid Date is 200 (two hundred) and the Price Index on the Reference Index Date preceding the due date of payment is 240 (two hundred forty), implying a Price Index Multiple of 1.2 (one point two), then the O&M Payment for that installment shall be the product of First Year O&M Cost and the applicable Price Index Multiple, which product shall be Rs.1.2cr. (Rupees one point two crore)

23.8 Mobilization Advance

The Authority shall, on request of the Concessionaire, make an advance payment in a sum not exceeding 10% (ten per cent) of the Bid Project Cost (the “**Mobilization Advance**”). This advance payment shall be made in two equal instalments. The Concessionaire may request the Authority for the first instalment of the advance payment at any time after the Appointed Date, along with furnishing a Bank Guarantee in a form satisfactory to the Authority. The Concessionaire may request the Authority for the second instalment of the advance payment at any time, after 60(sixty) days from the Appointed Date, along with furnishing a Bank Guarantee in a form satisfactory to the Authority. The first and second instalments of the Mobilization Advance shall be paid by the Authority within 30 (thirty) days of receipt of the respective requests in this behalf from the Concessionaire. The rate of interest on the Mobilization Advance shall be equal to the **average of one year MCLR of top 5 Scheduled Commercial Banks⁷ plus 1.25%**, compounded annually. The Mobilization Advance shall be deducted by the Authority in **8 (eight) equal instalments** from each of the payments to be made by the Authority to the Concessionaire in accordance with the provisions of Clause 23.4 and the interest thereon shall be recovered **from the 9th (fifth) and 10th (tenth) instalments**. As the Advance gets recovered from the running bills, stage payments, the BG for the amount equivalent to the amount of advance recovered may be released on the request of the Concessionaire.

The Concessionaire would be at liberty to either submit a substitute Bank Guarantee for the residual amount or multiple BGs for such residual amount in replacement of the existing BG.

23.9 Treatment of incomplete works

23.9.1 The Parties acknowledge and agree that in the event COD occurs upon issuance of a Provisional Certificate, the Annuity Payments and O&M Payments specified in this Article 23 shall be made as if all works comprising the Project have been completed. The works remaining incomplete shall be completed by the Concessionaire in accordance

⁷ The authority shall declare the list of Top 5 Scheduled Commercial Banks on 1st September every calendar year based on the balance sheet size as declared in their annual reports. The 1 year MCLR of the top 5 scheduled commercial banks shall be taken at the start of every quarter.

with the provisions of this Agreement and thereupon, the Completion Certificate shall be issued forthwith.

- 23.9.2 In the event the Authority determines that any incomplete works referred to in Clause 23.9.1 are not required to be completed for any reason, it shall modify the Scope of the Project in accordance with the provisions of Article 16 and the Completion Cost, Annuity Payments and O&M Payments shall be reduced on account of such Change of Scope as per the provisions of Article 16.



ARTICLE 24

Deleted



ARTICLE 25

ESCROW ACCOUNT

25.1 Escrow Account

- 25.1.1 The Concessionaire shall, prior to the Appointed Date, open and establish an Escrow Account with a Bank (the "Escrow Bank") in accordance with this Agreement read with the Escrow Agreement.
- 25.1.2 The nature and scope of the Escrow Account are fully described in the agreement (the "Escrow Agreement") to be entered into amongst the Concessionaire, the Authority, the Escrow Bank and the Senior Lenders through the Lenders' Representative, which shall be substantially in the form set forth in Schedule-O.

25.2 Deposits into Escrow Account

The Concessionaire shall deposit or cause to be deposited the following inflows and receipts into the Escrow Account:

- (a) All funds constituting the Financial Package;
- (b) All revenues from or in respect of the Project, including the proceeds of any rentals, deposits, capital receipts or insurance claims; and
- (c) All payments by the Authority, after deduction of any outstanding payments.

25.3 Withdrawals during Concession Period

- 25.3.1 The Concessionaire shall, at the time of opening the Escrow Account, give irrevocable instructions, by way of an Escrow Agreement, to the Escrow Bank instructing, *inter alia*, that deposits in the Escrow Account shall be appropriated in the following order every month, or at shorter intervals as necessary, and if not due in a month then appropriated proportionately in such month and retained in the Escrow Account and paid out there from in the month when due:

- (a) All taxes due and payable by the Concessionaire for and in respect of the Project;
- (b) Deleted;
- (c) All payments relating to construction of the Project, subject to and in accordance with the conditions, if any, set forth in the Financing Agreements;
- (d) O&M Expenses, subject to the ceiling, if any, set forth in the Financing Agreements;
- (e) O&M Expenses and other costs and expenses incurred by the Authority in accordance with the provisions of this Agreement, and certified by the Authority as due and payable to it;



PUBLIC PRIVATE PARTNERSHIP IN HYBRID ANNUITY PROJECTS

- (f) Any amounts due and payable to the Authority (other than under Clause 9.5);
- (g) Monthly proportionate provision of Debt Service due in an Accounting Year;
- (h) All payments and Damages certified by the Authority as due and payable to it by the Concessionaire;
- (i) Monthly proportionate provision of debt service payments due in an Accounting Year in respect of Subordinated Debt;
- (j) Any reserve requirements set forth in the Financing Agreements; and
- (k) Balance, if any, in accordance with the instructions of the Concessionaire.

25.3.2 The Concessionaire shall not in any manner modify the order of payment specified in Clause 25.3.1, except with the prior written approval of the Authority.

25.4 Withdrawals upon Termination

25.4.1 Notwithstanding anything to the contrary contained in this Agreement, all amounts standing to the credit of the Escrow Account shall, upon Termination, be appropriated in the following order:

- (a) All taxes due and payable by the Concessionaire for and in respect of the Project;
- (b) Deleted;
- (c) Percentage of Debt Due excluding Subordinated Debt if required to be as per the terms of this Agreement;
- (d) Outstanding payments due to the Authority;
- (e) All payments and Damages certified by the Authority as due and payable to it by the Concessionaire;
- (f) Retention and payments relating to the liability for defects and deficiencies set forth in Article 33;
- (g) Outstanding Debt Service including the balance of Debt Due;
- (h) Outstanding Subordinated Debt;
- (i) Incurred or accrued O&M Expenses;
- (j) Any other payments required to be made under this Agreement; and
- (k) Balance, if any, in accordance with the instructions of the Concessionaire;

Provided that no appropriations shall be made under Sub-clause (k) of this Clause 25.4.1 until a Vesting Certificate has been issued by the Authority under the provisions of Article 32.

25.4.2 The provisions of this Article 25 and the instructions contained in the Escrow Agreement shall remain in full force and effect until the obligations set forth in Clause 25.4.1 have been discharged.

ARTICLE 26

INSURANCE

26.1 Insurance during Concession Period

The Concessionaire shall effect and maintain at its own cost, during the Construction Period and the Operation Period, such insurances for such maximum sums as may be required under the Financing Agreements and Applicable Laws, and such insurances as may be necessary or prudent in accordance with Good Industry Practice. The Concessionaire shall also effect and maintain such insurances as may be necessary for mitigating the risks that may devolve on the Authority as a consequence of any act or omission of the Concessionaire during the Construction Period. The Concessionaire shall procure that in each insurance policy, the Authority shall be a co-insured and that the insurer shall pay the proceeds of insurance into the Escrow Account. For the avoidance of doubt, the level of insurance to be maintained by the Concessionaire after repayment of Senior Lenders' dues in full shall be determined on the same principles as applicable for determining the level of insurance prior to such repayment of Senior Lenders' dues.

26.2 Insurance Cover

Without prejudice to the provisions contained in Clause 26.1, the Concessionaire shall, during the Operation Period, procure and maintain Insurance Cover including but not limited to the following:

- (a) Loss, damage or destruction of the Project Assets, including assets handed over by the Authority to the Concessionaire, at replacement value;
- (b) Comprehensive third party liability insurance including injury to or death of personnel of the Authority or others caused by the Project;
- (c) The Concessionaire's general liability arising out of the Concession;
- (d) Liability to third parties for goods or property damage;
- (e) Workmen's compensation insurance; and
- (f) any other insurance that may be necessary to protect the Concessionaire and its employees, including all Force Majeure Events that are insurable at commercially reasonable premiums and not otherwise covered in items(a) to (e) above.

26.3 Notices to the Authority

No later than 45 (forty five) days prior to commencement of the Construction Period or the Operation Period, as the case may be, the Concessionaire shall by notice furnish to the Authority, in reasonable detail, information in respect of the insurances that it proposes to effect and maintain in accordance with this Article 26. Within 30 (thirty) days of receipt of such notice, the Authority may require the Concessionaire to effect and maintain such other insurances as may be necessary pursuant hereto, and in the



event of any difference or disagreement relating to any such insurance, the Dispute Resolution Procedure shall apply.

26.4 Evidence of Insurance Cover

All insurances obtained by the Concessionaire in accordance with this Article 26 shall be maintained with insurers on terms consistent with Good Industry Practice. Within 15 (fifteen) days of obtaining any insurance cover, the Concessionaire shall furnish to the Authority, notarized true copies of the certificate(s) of insurance, copies of insurance policies and premium payment receipts in respect of such insurance, and no such insurance shall be cancelled, modified, or allowed to expire or lapse until the expiration of at least 45 (forty five) days after notice of such proposed cancellation, modification or nonrenewal has been delivered by the Concessionaire to the Authority.

26.5 Remedy for failure to insure

If the Concessionaire shall fail to effect and keep in force all insurances for which it is responsible pursuant hereto, the Authority shall have the option to either keep in force any such insurances, and pay such premier and recover the costs thereof from the Concessionaire, or in the event of computation of a Termination Payment, treat an amount equal to the Insurance Cover as deemed to have been received by the Concessionaire.

26.6 Waiver of subrogation

All insurance policies in respect of the insurance obtained by the Concessionaire pursuant to this Article 26 shall include a waiver of any and all rights of subrogation or recovery of the insurers thereunder against, inter alia, the Authority, and its assigns, successors, undertakings and their subsidiaries, affiliates, employees, insurers and underwriters, and of any right of the insurers to any set-off or counterclaim or any other deduction, whether by attachment or otherwise, in respect of any liability of any such person insured under any such policy or in any way connected with any loss, liability or obligation covered by such policies of insurance.

26.7 Concessionaire's waiver

The Concessionaire hereby further releases, assigns and waives any and all rights of subrogation or recovery against, inter alia, the Authority and its assigns, undertakings and their subsidiaries, affiliates, employees, successors, insurers and underwriters, which the Concessionaire may otherwise have or acquire in or from or in any way connected with any loss, liability or obligation covered by policies of insurance maintained or required to be maintained by the Concessionaire pursuant to this Agreement (other than third party liability insurance policies) or because of deductible clauses in or inadequacy of limits of any such policies of insurance.

26.8 Application of insurance proceeds

The proceeds from all insurance claims, except life and injury, shall be paid to the Concessionaire by credit to the Escrow Account and it shall, notwithstanding anything to the contrary contained in Clause 25.3, apply such proceeds for any necessary repair,

reconstruction, reinstatement, replacement, improvement or delivery of the Project, and the balance remaining, if any, shall be applied in accordance with the provisions contained in this behalf in the Financing Agreements.

26.9 Compliance with conditions of insurance policies

The Concessionaire expressly acknowledges and undertakes to fully indemnify the Authority from and against all losses and claims arising from the Concessionaire's failure to comply with conditions imposed by the insurance policies affected in accordance with this Agreement.



ARTICLE 27

ACCOUNTS AND AUDIT

27.1 Audited accounts

27.1.1 The Concessionaire shall maintain books of accounts recording all its receipts (including all revenues derived/collected by it from or on account of the Project and/or its use), income, expenditure, payments (including payments from the Escrow Account), assets and liabilities, in accordance with this Agreement, Good Industry Practice, Applicable Laws and Applicable Permits. The Concessionaire shall provide 2 (two) copies of its Balance Sheet, Cash Flow Statement and Profit and Loss Account, along with a report thereon by its Statutory Auditors, within 180 (one hundred and eighty) days of the close of the Accounting Year to which they pertain and such audited accounts, save and except where expressly provided to the contrary, shall form the basis of payments by either Party under this Agreement. The Authority shall have the right to inspect the records of the Concessionaire during office hours and require copies of relevant extracts of books of accounts, duly certified by the Statutory Auditors, to be provided to the Authority for verification of basis of payments, and in the event of any discrepancy or error being found, the same shall be rectified and such rectified account shall form the basis of payments by either Party under this Agreement.

27.1.2 The Concessionaire shall, within 30 (thirty) days of the close of each quarter of an Accounting Year, furnish to the Authority its unaudited financial results in respect of the preceding quarter, in the manner and form prescribed by the Securities and Exchange Board of India for publication of quarterly results by the companies listed on a stock exchange.

27.1.3 On or before the thirty-first day of May each Year, the Concessionaire shall provide to the Authority, for the preceding Accounting Year, a statement duly audited by its Statutory Auditors giving summarized information on revenues derived from the Project, and such other information as the Authority may reasonably require.

27.2 Appointment of auditors

27.2.1 The Concessionaire shall appoint, and have during the subsistence of this Agreement as its Statutory Auditors, a firm chosen by it from the mutually agreed list of 5 (five) reputable firms of chartered accountants (the "**Panel of Chartered Accountants**"), such list to be prepared substantially in accordance with the criteria set forth in Schedule-P. All fees and expenses of the Statutory Auditors shall be borne by the Concessionaire.

27.2.2 The Concessionaire may terminate the appointment of its Statutory Auditors after a notice of 45 (forty five) days to the Authority, subject to the replacement Statutory Auditors being appointed from the Panel of Chartered Accountants.

27.2.3 Notwithstanding anything to the contrary contained in this Agreement, the Authority shall have the right, but not the obligation, to appoint at its cost from time to time and at any time, another firm (the "**Additional Auditors**") from the Panel of Chartered Accountants to audit and verify all those matters, expenses, costs, realizations and



things which the Statutory Auditors are required to do, undertake or certify pursuant to this Agreement.

27.3 Certification of claims by Statutory Auditors

Any claim or document provided by the Concessionaire to the Authority in connection with or relating to receipts, income, payments, costs, expenses, accounts or audit, and any matter incidental thereto shall be valid and effective only if certified by its Statutory Auditors. For the avoidance of doubt, such certification shall not be required for exchange of information in the normal course of business including the submission of any periodic information in pursuance of the provisions of this Agreement, save and except where such certification is expressly provided.

27.4 Set-off

In the event any amount is due and payable by the Authority to the Concessionaire, it may set-off any sums payable to it by the Concessionaire and pay the balance remaining. Any exercise by the Authority of its rights under this Clause 27.4 shall be without prejudice to any other rights or remedies available to it under this Agreement or otherwise.

27.5 Dispute resolution

In the event of there being any difference between the findings of the Additional Auditors or the Concurrent Auditors, as the case may be, and the certification provided by the Statutory Auditors, such Auditors shall meet to resolve the differences and if they are unable to resolve the same, such Dispute shall be resolved by the Authority by recourse to the Dispute Resolution Procedure.



Part V

Force Majeure and Termination



ARTICLE 28

FORCE MAJEURE

28.1 Force Majeure

As used in this Agreement, the expression "Force Majeure" or "Force Majeure Event" shall, save and except as expressly provided otherwise, mean occurrence in India of any or all of Non-Political Event, Indirect Political Event and Political Event, as defined in Clauses 28.2, 28.3 and 28.4 respectively, if it affects the performance by the Party claiming the benefit of Force Majeure (the "Affected Party") of its obligations under this Agreement and which act or event (a) is beyond the reasonable control of the Affected Party, and (b) the Affected Party could not have prevented or overcome by exercise of due diligence and following Good Industry Practice, and (c) has Material Adverse Effect on the Affected Party.

28.2 Non-Political Event

A Non-Political Event shall mean one or more of the following acts or events:

- (a) act of God, epidemic, extremely adverse weather conditions, lightning, earthquake, landslide, cyclone, flood, volcanic eruption, chemical or radioactive contamination or ionizing radiation, fire or explosion (to the extent of contamination or radiation or fire or explosion originating from a source external to the Site);
- (b) strikes or boycotts (other than those involving the Concessionaire, Contractors or their respective employees/representatives, or attributable to any act or omission of any of them) interrupting supplies and services to the Project for a continuous period of 24 (twenty four) hours and an aggregate period exceeding 7 (seven) days in an Accounting Year, and not being an Indirect Political Event set forth in Clause 28.3;
- (c) any failure or delay of a Contractor but only to the extent caused by another Non-Political Event and which does not result in any offsetting compensation being payable to the Concessionaire by or on behalf of such Contractor;
- (d) any judgment or order of any court of competent jurisdiction or statutory authority made against the Concessionaire in any proceedings for reasons other than (i) failure of the Concessionaire to comply with any Applicable Law or Applicable Permit, or (ii) on account of breach of any Applicable Law or Applicable Permit or of any contract, or (iii) enforcement of this Agreement, or (iv) exercise of any of its rights under this Agreement by the Authority;
- (e) The discovery of geological conditions, toxic contamination or archaeological remains on the Site that could not reasonably have been expected to be discovered through a site inspection, or
- (f) Any event or circumstances of a nature analogous to any of the foregoing.

28.3 Indirect Political Event

An Indirect Political Event shall mean one or more of the following acts or events:

- (a) An act of war (whether declared or undeclared), invasion, armed conflict or act of foreign enemy, blockade, embargo, riot, insurrection, terrorist or military action, civil commotion or politically motivated sabotage;
- (b) any political or economic upheaval, disturbance, movement, struggle or similar occurrence which could not have been anticipated or foreseen by a prudent person and which causes the construction or operation of the Project to be financially unviable or otherwise not feasible;
- (c) industry-wide or State-wide strikes or industrial action for a continuous period of 24 (twenty four) hours and exceeding an aggregate period of 7 (seven) days in an Accounting Year;
- (d) Deleted
- (e) failure of the Authority to permit the Concessionaire to continue its Construction Works, with or without modifications, in the event of stoppage of such works after discovery of any geological or archaeological finds or for any other reason;
- (f) Any failure or delay of a Contractor to the extent caused by any Indirect Political Event and which does not result in any offsetting compensation being payable to the Concessionaire by or on behalf of such Contractor;
- (g) Any Indirect Political Event that causes a Non-Political Event; or
- (h) Any event or circumstances of a nature analogous to any of the foregoing.

28.4 Political Event

A Political Event shall mean one or more of the following acts or events by or on account of any Government Instrumentality:

- (a) Change in Law, only if consequences thereof cannot be dealt with under and in accordance with the provisions of Article 35 and its effect, in financial terms, exceeds the sum specified in Clause 35.1;
- (b) Compulsory acquisition in national interest or expropriation of any Project Assets or rights of the Concessionaire or of the Contractors;
- (c) unlawful or unauthorized or without jurisdiction revocation of, or refusal to renew or grant without valid cause, any clearance, license, permit, authorization, no objection certificate, consent, approval or exemption required by the Concessionaire or any of the Contractors to perform their respective obligations under this Agreement and the Project Agreements; provided that such delay, modification, denial, refusal or revocation did not result from the Concessionaire's or any Contractor's inability or failure to comply with any

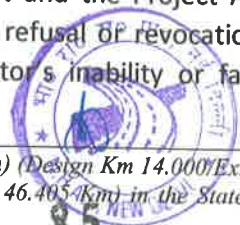

- condition relating to grant, maintenance or renewal of such clearance, license, authorization, no objection certificate, exemption, consent, approval or permit;
- (d) any failure or delay of a Contractor but only to the extent caused by another Political Event and which does not result in any offsetting compensation being payable to the Concessionaire by or on behalf of such Contractor; or
 - (e) Any event or circumstance of a nature analogous to any of the foregoing.

28.5 Duty to report Force Majeure Event

28.5.1 Upon occurrence of a Force Majeure Event, the Affected Party shall by notice report such occurrence to the other Party forthwith. Any notice pursuant hereto shall include full particulars of:

- (a) The nature and extent of each Force Majeure Event which is the subject of any claim for relief under this Article 28 with evidence in support thereof;
- (b) The estimated duration and the effect or probable effect which such Force Majeure Event is having or will have on the Affected Party's performance of its obligations under this Agreement;
- (c) the measures which the Affected Party is taking or proposes to take for alleviating the impact of such Force Majeure Event; and
- (d) Any other information relevant to the Affected Party's claim.

28.5.2 The Affected Party shall not be entitled to any relief for or in respect of a Force Majeure Event unless it shall have notified the other Party of the occurrence of the Force Majeure Event as soon as reasonably practicable, and in any event no later than 7 (seven) days after the Affected Party knew, or ought reasonably to have known, of its occurrence, and shall have given particulars of the probable material effect that the Force Majeure Event is likely to have on the performance of its obligations under this Agreement.

28.5.3 For so long as the Affected Party continues to claim to be materially affected by such Force Majeure Event, it shall provide the other Party with regular (and not less than weekly) reports containing information as required by Clause 28.5.1, and such other information as the other Party may reasonably request the Affected Party to provide.

28.6 Effect of Force Majeure Event on the Concession

28.6.1 Upon the occurrence of any Force Majeure Event prior to the Appointed Date, the period set forth in Clause 4.1 for fulfillment of Conditions Precedent and in Clause 22.1.1 for achieving Financial Close shall be extended by a period equal in length to the duration of the Force Majeure Event.

28.6.2 at any time after the Appointed Date, if any Force Majeure Event occurs:

- (a) before COD, the Construction Period and the dates set forth in the Project Completion Schedule shall be extended by a period equal in length to the duration for which such Force Majeure Event subsists; or

- (b) After COD, the Concessionaire shall be entitled to receive Annuity Payments plus interest due and payable under this Agreement.

Provided any payment to be made under this clause shall be subject to deduction of outstanding dues of the Authority, if any.

28.7 Allocation of costs arising out of Force Majeure

28.7.1 Upon occurrence of any Force Majeure Event prior to the Appointed Date, the Parties shall bear their respective costs and no Party shall be required to pay to the other Party any costs thereof.

28.7.2 Upon occurrence of a Force Majeure Event after the Appointed Date, the costs incurred and attributable to such event and directly relating to the Project (the "Force Majeure Costs") shall be allocated and paid as follows:

- (a) upon occurrence of a Non-Political Event, the Parties shall bear their respective Force Majeure Costs and neither Party shall be required to pay to the other Party any costs thereof;
- (b) upon occurrence of an Indirect Political Event, all Force Majeure Costs attributable to such Indirect Political Event, and not exceeding the Insurance Cover for such Indirect Political Event, shall be borne by the Concessionaire, and to the extent Force Majeure Costs exceed such Insurance Cover, one half of such excess amount shall be reimbursed by the Authority to the Concessionaire; and
- (c) Upon occurrence of a Political Event, all Force Majeure Costs attributable to such Political Event shall be reimbursed by the Authority to the Concessionaire.

For the avoidance of doubt, Force Majeure Costs may include interest payments on Debt Due, O&M Expenses, any increase in the cost of Construction Works on account of inflation and all other costs directly attributable to the Force Majeure Event, but shall not include any costs which are expressly covered under any provision of this Agreement or debt repayment obligations, and for determining such costs, information contained in the Financial Package may be relied upon to the extent that such information is relevant.

28.7.3 Save and except as expressly provided in this Article 28, neither Party shall be liable in any manner whatsoever to the other Party in respect of any loss, damage, cost, expense, claims, demands and proceedings relating to or arising out of occurrence or existence of any Force Majeure Event or exercise of any right pursuant hereto.

28.8 Termination Notice for Force Majeure Event

If a Force Majeure Event subsists for a period of 180 (one hundred and eighty) days or more within a continuous period of 365 (three hundred and sixty five) days, either Party may in its discretion terminate this Agreement by issuing a Termination Notice to the other Party without being liable in any manner whatsoever, save as provided in this Article 28, and upon issue of such Termination Notice, this Agreement shall, notwithstanding anything to the contrary contained herein, stand terminated forthwith; provided that before issuing such Termination Notice, the Party intending to issue the Termination Notice shall inform the other Party of such intention and grant 15 (fifteen)

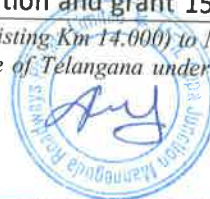

PUBLIC PRIVATE PARTNERSHIP IN HYBRID ANNUITY PROJECTS

day's time to make a representation, and may after the expiry of such 15 (fifteen) days period, whether or not it is in receipt of such representation, in its sole discretion issue the Termination Notice.

28.9 Termination Payment for Force Majeure Event

28.9.1 If Termination is on account of a Non-Political Event, the Authority shall make a Termination Payment to the Concessionaire in an amount to be calculated as under:

(i) Prior to COD:

Payment Milestone	Basis of calculation for termination payment
1st Payment Milestone	90% Debt Due or 0.68% of Bid Project Cost , whichever is lower
2nd Payment Milestone	90% Debt Due or 1.35% of Bid Project Cost , whichever is lower
3rd Payment Milestone	90% Debt Due or 5.40% of Bid Project Cost , whichever is lower
4th Payment Milestone	90% Debt Due or 9.45% of Bid Project Cost , whichever is lower
5th Payment Milestone	90% Debt Due or 13.50% of Bid Project Cost , whichever is lower
6th Payment Milestone	90% Debt Due or 17.55% of Bid Project Cost , whichever is lower
7th Payment Milestone	90% Debt Due or 21.60% of Bid Project Cost , whichever is lower
8th Payment Milestone	90% Debt Due or 25.65% of Bid Project Cost , whichever is lower
9th Payment Milestone	90% Debt Due or 29.70% of Bid Project Cost , whichever is lower
10th Payment Milestone	90% Debt Due or 33.75% of Bid Project Cost , whichever is lower

For the avoidance of doubt, it is clarified that in case of termination happening in between two Payment Milestones, for the purpose of calculation of Debt Due, the milestone achieved would only be considered; provided further the above payment so calculated above shall be reduced by Insurance Cover.

(ii) In case Termination occurs on or after COD, the Authority shall make a Termination Payment to the Concessionaire in an amount equal to 75% (seventy five percent) of Annuity Payments remaining unpaid for and in respect of the remaining Concession Period, including interest thereon up to the Transfer Date. Provided further the above payment so calculated above shall be reduced by Insurance Cover.

28.9.2 If Termination is on account of an Indirect Political Event, the Authority shall make a Termination Payment to the Concessionaire in an amount equal to:

PUBLIC PRIVATE PARTNERSHIP IN HYBRID ANNUITY PROJECTS

- (i) In case termination occurs prior to COD:
- (a) Debt Due payment calculated as per the table below less Insurance Cover; provided that if any insurance claims forming part of the Insurance Cover are not admitted and paid, then 80% (eighty per cent) of such unpaid claims shall be included in the computation of Debt Due. Further the Debt Due would be calculated as per the table provided below:

Payment Milestone	Basis of calculation for Debt Due payment
1st Payment Milestone	Debt Due or 0.75% of Bid Project Cost , whichever is lower
2nd Payment Milestone	Debt Due or 1.50% of Bid Project Cost , whichever is lower
3rd Payment Milestone	Debt Due or 6.00% of Bid Project Cost , whichever is lower
4th Payment Milestone	Debt Due or 10.50% of Bid Project Cost , whichever is lower
5th Payment Milestone	Debt Due or 15.00% of Bid Project Cost , whichever is lower
6th Payment Milestone	Debt Due or 19.50% of Bid Project Cost , whichever is lower
7th Payment Milestone	Debt Due or 24.00% of Bid Project Cost , whichever is lower
8th Payment Milestone	Debt Due or 28.50% of Bid Project Cost , whichever is lower
9th Payment Milestone	Debt Due or 33.00% of Bid Project Cost , whichever is lower
10th Payment Milestone	Debt Due or 37.50% of Bid Project Cost , whichever is lower

For the avoidance of doubt, it is clarified that in case of termination happening in between two Payment Milestones, for the purpose of calculation of Debt Due, the milestone achieved would only be considered ; and

- (b) 110% (one hundred and ten per cent) of the Adjusted Equity;
- (ii) In case Termination occurs on or after COD, the Authority shall make a Termination Payment to the Concessionaire in an amount equal to 90% (ninety percent) of Annuity Payments remaining unpaid for and in respect of the remaining Concession Period, including interest thereon up to the Transfer Date.

28.9.3 If Termination is on account of a Political Event, the Authority shall make a Termination Payment to the Concessionaire in an amount that would be payable under Clause 31.3.3 as if it were an Authority Default.

28.10 Dispute resolution

In the event that the Parties are unable to agree in good faith about the occurrence or existence of a Force Majeure Event, such Dispute shall be finally settled in accordance with the Dispute Resolution Procedure; provided that the burden of proof as to the occurrence or existence of such Force Majeure Event shall be upon the Party claiming relief and/or excuse on account of such Force Majeure Event

28.11 Excuse from performance of obligations

If the Affected Party is rendered wholly or partially unable to perform its obligations under this Agreement because of a Force Majeure Event, it shall be excused from performance of such of its obligations to the extent it is unable to perform on account of such Force Majeure Event; provided that:

- (a) The suspension of performance shall be of no greater scope and of no longer duration than is reasonably required by the Force Majeure Event;
- (b) the Affected Party shall make all reasonable efforts to mitigate or limit damage to the other Party arising out of or as a result of the existence or occurrence of such Force Majeure Event and to cure the same with due diligence; and
- (c) When the Affected Party is able to resume performance of its obligations under this Agreement, it shall give to the other Party notice to that effect and shall promptly resume performance of its obligations hereunder.

28.12 Deleted



ARTICLE 29

COMPENSATION FOR BREACH OF AGREEMENT

29.1 Compensation for default by the Concessionaire

Subject to the provisions of Clause 29.4, in the event of the Concessionaire being in material breach or default of this Agreement, it shall pay to the Authority by way of compensation, all direct costs suffered or incurred by the Authority as a consequence of such material breach or default, within 30 (thirty) days of receipt of the demand supported by necessary particulars thereof; provided that no compensation shall be payable under this Clause 29.1 for any material breach or default in respect of which Damages are expressly specified and payable under this Agreement or for any consequential losses incurred by the Authority.

29.2 Compensation for default by the Authority

Subject to the provisions of Clause 29.4, in the event of the Authority being in material breach or default of this Agreement at any time after the Appointed Date, it shall pay to the Concessionaire by way of compensation, all direct costs suffered or incurred by the Concessionaire as a consequence of such material breach or default within 30 (thirty) days of receipt of the demand supported by necessary particulars thereof; provided that no such compensation shall be payable for any material breach or default in respect of which Damages have been expressly specified in this Agreement. For the avoidance of doubt, compensation payable may include interest payments on debt, O&M Expenses, any increase in capital costs on account of inflation and all other costs directly attributable to such material breach or default but shall not include loss of Annuity Payments, debt repayment obligations or other consequential losses, loss of profit, EPC Contractors claims, and for determining such compensation, information contained in the Financial Package and the Financial Model may be relied upon to the extent it is relevant.

29.3 Deleted

29.4 Mitigation of costs and damage

The Affected Party shall make all reasonable efforts to mitigate or limit the costs and damage arising out of or as a result of breach of Agreement by the other Party.



ARTICLE 30

SUSPENSION OF CONCESSIONAIRE'S RIGHTS

30.1 Suspension upon Concessionaire Default

Upon occurrence of a Concessionaire Default, the Authority shall be entitled, without prejudice to its other rights and remedies under this Agreement including its rights of Termination hereunder, to (a) suspend all rights of the Concessionaire under this Agreement, and pursuant hereto, and (b) exercise such rights itself and perform the obligations hereunder or authorize any other person to exercise or perform the same on its behalf during such suspension (the "Suspension"). Suspension hereunder shall be effective forthwith upon issue of notice by the Authority to the Concessionaire and may extend up to a period not exceeding 180 (one hundred and eighty) days from the date of issue of such notice; provided that upon written request from the Concessionaire and the Lenders' Representative, the Authority shall extend the aforesaid period of 180 (one hundred and eighty) days by a further period not exceeding 90 (ninety) days.

30.2 Authority to act on behalf of Concessionaire

30.2.1 During the period of Suspension, the Authority shall, on behalf of the Concessionaire, collect all revenues under and in accordance with this Agreement and deposit the same in the Escrow Account. The Authority shall be entitled to make withdrawals from the Escrow Account for meeting the O&M Expenses and for meeting the costs incurred by it for remedying and rectifying the cause of Suspension, and thereafter for defraying the expenses specified in Clause 25.3.

30.2.2 During the period of Suspension hereunder, all rights and liabilities vested in the Concessionaire in accordance with the provisions of this Agreement shall continue to vest in the Concessionaire and all things done or actions taken, including expenditure incurred by the Authority for discharging the obligations of the Concessionaire under and in accordance with this Agreement and the Project Agreements, shall be deemed to have been done or taken for and on behalf of the Concessionaire and the Concessionaire undertakes to indemnify the Authority for all costs incurred- during such period. The Concessionaire hereby licenses and sub-licenses respectively, the Authority or any other person authorized by it under Clause 30.1 to use during Suspension, all Intellectual Property belonging to or licensed to the Concessionaire with respect to the Project and its design, engineering, construction, operation and maintenance, and which is used or created by the Concessionaire in performing its obligations under the Agreement.

30.3 Revocation of Suspension

30.3.1 In the event that the Authority shall have rectified or removed the cause of Suspension within a period not exceeding 90 (ninety) days from the date of Suspension, it shall revoke the Suspension forthwith and restore all rights of the Concessionaire under this Agreement. For the avoidance of doubt, the Parties expressly agree that the Authority may, in its discretion, revoke the Suspension at any time, whether or not the cause of Suspension has been rectified or removed hereunder

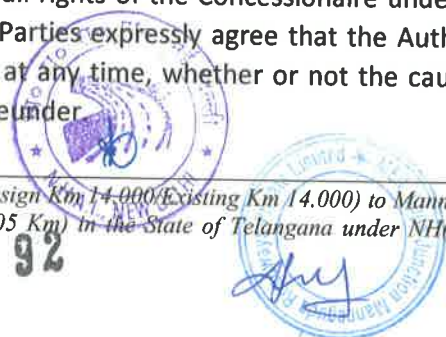

30.3.2 Upon the Concessionaire having cured the Concessionaire Default within a period not exceeding 90 (ninety) days from the date of Suspension, the Authority shall revoke the Suspension forthwith and restore all rights of the Concessionaire under this Agreement.

30.4 Substitution of Concessionaire

At any time during the period of Suspension, the Lenders' Representative, on behalf of Senior Lenders, shall be entitled to substitute the Concessionaire under and in accordance with the Substitution Agreement, and upon receipt of notice there under from the Lenders' Representative, the Authority shall withhold Termination for a period not exceeding 180 (one hundred and eighty) days from the date of Suspension, and any extension thereof under Clause 30.1, for enabling the Lenders' Representative to exercise its rights of substitution on behalf of Senior Lenders.

30.5 Termination

30.5.1 At any time during the period of Suspension under this Article 30, the Concessionaire may by notice require the Authority to revoke the Suspension and issue a Termination Notice. Subject to the rights of the Lenders' Representative to undertake substitution in accordance with the provisions of this Agreement and within the period specified in Clause 30.4, the Authority shall, within 15 (fifteen) days of receipt of such notice, terminate this Agreement under and in accordance with Article 31 as if it is a Concessionaire Default under Clause 31.1.

30.5.2 Notwithstanding anything to the contrary contained in this Agreement, in the event that Suspension is not revoked within 180 (one hundred and eighty) days from the date of Suspension hereunder or within the extended period, if any, set forth in Clause 30.1, the Concession Agreement shall, upon expiry of the aforesaid period, be deemed to have been terminated by mutual agreement of the Parties and all the provisions of this Agreement shall apply, mutatis mutandis, to such Termination as if a Termination Notice had been issued by the Authority upon occurrence of a Concessionaire Default.



ARTICLE 31

TERMINATION

31.1 Termination for Concessionaire Default

31.1.1 Save as otherwise provided in this Agreement, in the event that any of the defaults specified below shall have occurred, and the Concessionaire fails to cure the default within the Cure Period set forth below, or where no Cure Period is specified, then within a Cure Period of 60 (sixty) days, the Concessionaire shall be deemed to be in default of this Agreement (the "**Concessionaire Default**"), unless the default has occurred as a result of any breach of this Agreement by the Authority or due to Force Majeure. The defaults referred to herein shall include the following:

- (a) The Performance Security has been encashed and appropriated in accordance with Clause 9.2 and the Concessionaire fails to replenish or provide fresh Performance Security within a Cure Period of 15 (fifteen) days;
- (b) subsequent to the replenishment or furnishing of fresh Performance Security in accordance with Clause 9.2, the Concessionaire fails to meet any Condition Precedent or cure the Concessionaire Default, as the case may be, for which whole or part of the Performance Security was appropriated, within a Cure Period of 120 (one hundred and twenty) days;
- (c) the Concessionaire does not achieve the latest outstanding Project Milestone due in accordance with the provisions of Schedule-G and continues to be in default for 120 (one hundred and twenty) days;
- (d) The Concessionaire abandons or manifests intention to abandon the construction or operation of the Project without the prior written consent of the Authority;
- (e) COD does not occur within the period specified in Clause 12.3.3;
- (f) the Punch List items have not been completed within the period set forth in Clause 14.4.1;
- (g) the Concessionaire is in breach of the Maintenance Requirements or the Safety Requirements, as the case may be;
- (h) the Concessionaire has failed to make any payment to the Authority within the period specified in this Agreement;
- (i) an Escrow Default has occurred and the Concessionaire fails to cure the default within a Cure Period of 15 (fifteen) days;
- (j) upon occurrence of a Financial Default, the Lenders' Representative has by notice required the Authority to undertake Suspension or Termination, as the case may be, in accordance with the Substitution Agreement and the Concessionaire fails to cure the default within the Cure Period specified hereinabove;
- (k) a breach of any of the Project Agreements by the Concessionaire has caused a Material Adverse Effect;
- (l) the Concessionaire creates any Encumbrance in breach of this Agreement;



- (m) the Concessionaire repudiates this Agreement or otherwise takes any action or evidences or conveys an intention not to be bound by the Agreement;
- (n) a Change in Ownership has occurred in breach of the provisions of Clause 5.3;
- (o) there is a transfer, pursuant to law either of (i) the rights and/or obligations of the Concessionaire under any of the Project Agreements, or of (ii) all or part of the assets or undertaking of the Concessionaire, and such transfer causes a Material Adverse Effect;
- (p) an execution levied on any of the assets of the Concessionaire has caused a Material Adverse Effect;
- (q) the Concessionaire is adjudged bankrupt or insolvent, or if a trustee or receiver is appointed for the Concessionaire or for the whole or material part of its assets that has a material bearing on the Project;
- (r) the Concessionaire has been, or is in the process of being liquidated, dissolved, wound-up, amalgamated or reconstituted in a manner that would cause, in the reasonable opinion of the Authority, a Material Adverse Effect;
- (s) a resolution for winding up of the Concessionaire is passed, or any petition for winding up of the Concessionaire is admitted by a court of competent jurisdiction and a provisional liquidator or receiver is appointed and such order has not been set aside within 90 (ninety) days of the date thereof or the Concessionaire is ordered to be wound up by a court except for the purpose of amalgamation or reconstruction; provided that, as part of such amalgamation or reconstruction, the entire property, assets and undertaking of the Concessionaire are transferred to the amalgamated or reconstructed entity and that the amalgamated or reconstructed entity has unconditionally assumed the obligations of the Concessionaire under this Agreement and the Project Agreements; and provided that:
 - (i) the amalgamated or reconstructed entity has the capability and operating experience necessary for the performance of its obligations under this Agreement and the Project Agreements;
 - (ii) the amalgamated or reconstructed entity has the financial standing to perform its obligations under this Agreement and the Project Agreements and has a credit worthiness at least as good as that of the Concessionaire as at the Appointed Date; and
 - (iii) Each of the Project Agreements remains in full force and effect;
- (t) any representation or warranty of the Concessionaire herein contained which is, as of the date hereof, found to be materially false, incorrect or misleading or the Concessionaire is at any time hereafter found to be in breach thereof;
- (u) the Concessionaire submits to the Authority any statement, notice or other document, in written or electronic form, which has a material effect on the Authority's rights, obligations or interests and which is false in material particulars;
- (v) the Concessionaire has failed to fulfill any obligation, for which failure Termination has been specified in this Agreement;
- (w) the Concessionaire issues a Termination Notice in violation of this Agreement;
- (x) the Concessionaire commits a default in complying with any other provision of this Agreement if such default causes a Material Adverse Effect on the Authority.

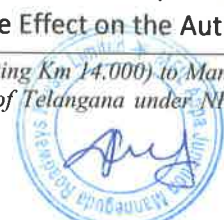

31.1.2 Without prejudice to any other rights or remedies which the Authority may have under this Agreement, upon occurrence of a Concessionaire Default, the Authority shall be entitled to terminate this Agreement by issuing a Termination Notice to the Concessionaire; provided that before issuing the Termination Notice, the Authority shall by a notice inform the Concessionaire of its intention to issue such Termination Notice and grant 15 (fifteen) days to the Concessionaire to make a representation, and may after the expiry of such 15 (fifteen) days, whether or not it is in receipt of such representation, issue the Termination Notice, subject to the provisions of Clause 31.1.3.

31.1.3 The Authority shall, if there be Senior Lenders, send a copy of its notice of intention to issue a Termination Notice referred to in Clause 31.1.2 to inform the Lenders' Representative and grant 15 (fifteen) days to the Lenders' Representative, for making a representation on behalf of the Senior Lenders stating the intention to substitute the Concessionaire in accordance with the Substitution Agreement. In the event the Authority receives such representation on behalf of Senior Lenders, it shall, in its discretion, either withhold Termination for a period not exceeding 180 (one hundred and eighty) days from the date of such representation or exercise its right of Suspension, as the case may be, for enabling the Lenders' Representative to exercise the Senior Lenders' right of substitution in accordance with the Substitution Agreement:

Provided that the Lenders' Representative may, instead of exercising the Senior Lenders' right of substitution, procure that the default specified in the notice is cured within the aforesaid period of 180 (one hundred and eighty) days, and upon such curing thereof, the Authority shall withdraw its notice referred to above and restore all the rights of the Concessionaire.

Provided further that upon written request from the Lenders' Representative and the Concessionaire, the Authority shall extend the aforesaid period of 180 (one hundred and eighty) days by such further period not exceeding 90 (ninety) days, as the Authority may deem appropriate.

31.2 Termination for Authority Default

31.2.1 In the event that any of the defaults specified below shall have occurred, and the Authority fails to cure such default within a Cure Period of 90 (ninety) days or such longer period as has been expressly provided in this Agreement, the Authority shall be deemed to be in default of this Agreement (the "**Authority Default**") unless the default has occurred as a result of any breach of this Agreement by the Concessionaire or due to Force Majeure. The defaults referred to herein shall include the following:

- (a) The Authority commits a material default in complying with any of the provisions of this Agreement and such default has a Material Adverse Effect on the Concessionaire;
- (b) The Authority has failed to make any payment to the Concessionaire within the period specified in this Agreement;



- (c) The Authority fails to provide, within a period of 180 (one hundred and eighty days) from the Appointed Date, statutory clearances required for construction of the Project; or
- (d) The Authority repudiates this Agreement or otherwise takes any action that amounts to or manifests an irrevocable intention not to be bound by this Agreement.

31.2.2 Without prejudice to any other right or remedy which the Concessionaire may have under this Agreement, upon occurrence of an Authority Default, the Concessionaire shall, subject to the provisions of the Substitution Agreement, be entitled to terminate this Agreement by issuing a Termination Notice to the Authority; provided that before issuing the Termination Notice, the Concessionaire shall by a notice inform the Authority of its intention to issue the Termination Notice and grant 15 (fifteen) days to the Authority to make a representation, and may after the expiry of such 15 (fifteen) days, whether or not it is in receipt of such representation, issue the Termination Notice.

31.3 Termination Payment

31.3.1 Upon Termination on account of a Concessionaire Default during the Operation Period, the Authority shall pay to the Concessionaire, by way of Termination Payment, an amount equal to 65% (sixty five percent) of the sum of Annuity Payments remaining unpaid for and in respect of the Concession Period, including interest thereon up to the Transfer Date.

31.3.2 Notwithstanding to the provisions of Clause 31.3.1 upon Termination on account of Concessionaire Default during the Construction Period, the Termination Payment shall be based on the Payment Milestone achieved which is in terms of the Physical Progress made by the Concessionaire in the Project and the Termination Payment corresponding to the achieved Payment Milestone shall be as follows:

Payment Milestone	Termination Payment
1st Payment Milestone	NIL
2nd Payment Milestone	NIL
3rd Payment Milestone	50% of Debt Due or 3.00% of Bid Project Cost , whichever is lower
4th Payment Milestone	55% of Debt Due or 5.78% of Bid Project Cost , whichever is lower
5th Payment Milestone	60% of Debt Due or 9.00% of Bid Project Cost , whichever is lower
6th Payment Milestone	65% of Debt Due or 12.68% of Bid Project Cost , whichever is lower
7th Payment Milestone	70% of Debt Due or 16.80% of Bid Project Cost , whichever is lower
8th Payment Milestone	75% of Debt Due or 21.38% of Bid Project Cost , whichever is lower
9th Payment Milestone	80% of Debt Due or 26.40% of Bid Project Cost , whichever is lower



PUBLIC PRIVATE PARTNERSHIP IN HYBRID ANNUITY PROJECTS

10th Payment Milestone	85% of Debt Due or 31.88% of Bid Project Cost , whichever is lower
------------------------	--

For the avoidance of doubt, it is clarified that in case of termination happening in between two Payment Milestones, for the purpose of calculation of Termination Payment, the milestone achieved would only be considered.

31.3.3 Upon Termination on account of an Authority Default, the Authority shall pay to the Concessionaire, by way of Termination Payment, an amount equal to:

- (i) In case the termination occurs prior to COD
- (a) Debt Due payment calculated as per the table below less Insurance Cover; provided that if any insurance claims forming part of the Insurance Cover are not admitted and paid, then 80% (eighty per cent) of such unpaid claims shall be included in the computation of Debt Due. Further the Debt Due would be calculated as per the table provided below:

Payment Milestone	Basis of calculation for Debt Due payment
1st Payment Milestone	Debt Due or 0.75% of Bid Project Cost , whichever is lower
2nd Payment Milestone	Debt Due or 1.50% of Bid Project Cost , whichever is lower
3rd Payment Milestone	Debt Due or 6.00% of Bid Project Cost , whichever is lower
4th Payment Milestone	Debt Due or 10.50% of Bid Project Cost , whichever is lower
5th Payment Milestone	Debt Due or 15.00% of Bid Project Cost , whichever is lower
6th Payment Milestone	Debt Due or 19.50% of Bid Project Cost , whichever is lower
7th Payment Milestone	Debt Due or 24.00% of Bid Project Cost , whichever is lower
8th Payment Milestone	Debt Due or 28.50% of Bid Project Cost , whichever is lower
9th Payment Milestone	Debt Due or 33.00% of Bid Project Cost , whichever is lower
10th Payment Milestone	Debt Due or 37.50% of Bid Project Cost , whichever is lower

For the avoidance of doubt, it is clarified that in case of termination happening in between two Payment Milestones, for the purpose of calculation of Debt Due, the milestone achieved would only be considered; and

- (b) 150% (one hundred and fifty per cent) of the Adjusted Equity;
- (ii) In case the termination occurs on or after COD, the Authority shall pay to the Concessionaire, by way of Termination Payment, an amount equal to sum of

Annuity Payments remaining unpaid for and in respect of the Concession Period, including interest thereon up to the Transfer Date.

31.3.4 Termination Payment shall become due and payable to the Concessionaire within 15 (fifteen) days of a demand being made by the Concessionaire to the Authority with the necessary particulars, and in the event of any delay, the Authority shall pay interest at a rate equal to 3% (three per cent) above the daily average Bank Rate on the amount of Termination Payment remaining unpaid; provided that such delay shall not exceed 90 (ninety) days. For the avoidance of doubt, it is expressly agreed that Termination Payment shall constitute full discharge by the Authority of its payment obligations in respect thereof hereunder.

31.3.5 The Concessionaire expressly agrees that Termination Payment under this Article 31 shall constitute a full and final settlement of all claims of the Concessionaire on account of Termination of this Agreement for any reason whatsoever and that the Concessionaire or any shareholder thereof shall not have any further right or claim under any law, treaty, convention, contract or otherwise.

31.4 Certain limitations on Termination Payment

31.4.1 During the Construction Period, Termination Payment due and payable under this Agreement shall be computed with reference to the Debt Due in accordance with the provisions of this Agreement. The Parties also agree that for the purposes of computing Termination Payment, the Debt Due shall at no time exceed 85% (eighty five per cent) of the Total Project Cost.

31.4.2 The amount payable in respect of any Debt Due expressed in foreign currency shall be computed at the Reference Exchange Rate for conversion into the relevant foreign currency as on the date of Termination Payment. Provided further that all borrowings in foreign currency shall be restricted to the financing of Total Project Cost and any borrowings in excess thereof shall not qualify for computation of Termination Payment. It is clarified that the rate of conversion of such foreign currency shall be calculated on the date on which the Agreement is terminated.

31.5 Other rights and obligations of the Authority

Upon Termination for any reason whatsoever, the Authority shall:

- (a) Be deemed to have taken possession and control of the Project forthwith;
- (b) Take possession and control of all materials, stores, implements, construction plants and equipment on or about the Site;
- (c) Be entitled to restrain the Concessionaire and any person claiming through or under the Concessionaire from entering upon the Site or any part of the Project;
- (d) Require the Concessionaire to comply with the Divestment Requirements set forth in Clause 32.1; and
- (e) succeed upon election by the Authority, without the necessity of any further action by the Concessionaire, to the interests of the Concessionaire under such



of the Project Agreements as the Authority may in its discretion deem appropriate, and shall upon such election be liable to the Contractors only for compensation accruing and becoming due and payable to them under the terms of their respective Project Agreements from and after the date the Authority elects to succeed to the interests of the Concessionaire. For the avoidance of doubt, the Concessionaire acknowledges and agrees that all sums claimed by such Contractors as being -due and owing for works and services performed or accruing on account of any act, omission or event prior to such date shall constitute debt between the Concessionaire and such Contractors, and the Authority shall not in any manner be liable for such sums. It is further agreed that in the event the Authority elects to cure any outstanding defaults under such Project Agreements, the amount expended by the Authority for this purpose shall be deducted from the Termination Payment.

31.6 Survival of rights

Notwithstanding anything to the contrary contained in this Agreement, but subject to the provisions of Clause 31.3.5, any Termination pursuant to the provisions of this Agreement shall be without prejudice to the accrued rights of either Party including its right to claim and recover money damages, insurance proceeds, security deposits, and other rights and remedies, which it may have in law or contract. All rights and obligations of either Party under this Agreement, including Termination Payments and Divestment Requirements, shall survive the Termination to the extent such survival is necessary for giving effect to such rights and obligations.



ARTICLE 32

DIVESTMENT OF RIGHTS AND INTEREST

32.1 Divestment Requirements

32.1.1 Upon Termination, the Concessionaire shall comply with and conform to the following Divestment Requirements:

- (a) Notify to the Authority forthwith the location and particulars of all Project Assets;
- (b) deliver forthwith the actual or constructive possession of the Project, free and clear of all Encumbrances, save and except to the extent set forth in the Substitution Agreement;
- (c) cure all Project Assets, including the road, bridges, structures and equipment, of all defects and deficiencies so that the Project is compliant with the Maintenance Requirements; provided that in the event of Termination during the Construction Period, all Project Assets shall be handed over on 'as is where is' basis after bringing them to a safe condition;
- (d) deliver and transfer relevant records, reports, Intellectual Property and other licenses pertaining to the Project and its design, engineering, construction, operation and maintenance, including all programmers and manuals pertaining thereto, and complete 'as built' Drawings as on the Transfer Date. For the avoidance of doubt, the Concessionaire represents and warrants that the Intellectual Property delivered hereunder shall be adequate and complete for the design, engineering, construction, operation and maintenance of the Project and shall be assigned to the Authority free of any Encumbrance;
- (e) Transfer and/or deliver all Applicable Permits to the extent permissible under Applicable Laws;
- (f) execute such deeds of conveyance, documents and other writings as the Authority may reasonably require for conveying, divesting and assigning all the rights, title and interest of the Concessionaire in the Project Assets, including manufacturers' warranties in respect of any plant or equipment and the right to receive outstanding insurance claims to the extent due and payable to the Authority, absolutely unto the Authority or its nominee; and
- (g) Comply with all other requirements as may be prescribed or required under Applicable Laws for completing the divestment and assignment of all rights, title and interest of the Concessionaire in the Project, free from all Encumbrances, absolutely unto the Authority or to its nominee.

32.1.2 Subject to the exercise by the Authority of its rights under this Agreement or under any of the Project Agreements to perform or procure the performance by a third party of any of the obligations of the Concessionaire, the Parties shall continue to perform their obligations under this Agreement, notwithstanding the issuance of any Termination



Notice, until the Termination of this Agreement becomes effective in accordance with its terms.

32.2 Inspection and cure

Not earlier than 90 (ninety) days prior to Termination but not later than 15 (fifteen) days prior to the effective date of such Termination, the Independent Engineer shall verify, after giving due notice to the Concessionaire specifying the time, date and place of such verification and/or inspection, compliance by the Concessionaire with the Maintenance Requirements, and if required, cause appropriate tests to be carried out at the Concessionaire's cost for this purpose. Defaults, if any, in the Maintenance Requirements shall be cured by the Concessionaire at its cost and the provisions of Article 33 shall apply, mutatis mutandis, in relation to curing of defects or deficiencies under this Article 32.

32.3 Cooperation and assistance on transfer of Project

32.3.1 The Parties shall cooperate on a best effort basis and take all necessary measures, in good faith, to achieve a smooth transfer of the Project in accordance with the provisions of this Agreement so as to protect the safety of and avoid undue delay or inconvenience to the Users, other members of the public or the lawful occupiers of any part of the Site.

32.3.2 The Parties shall provide to each other, 9 (nine) months prior to the Transfer Date in the event of Termination by efflux of time and immediately in the event of either Party conveying to the other Party its intent to issue a Termination Notice, as the case may be, as much information and advice as is reasonably practicable regarding the proposed arrangements for operation of the Project following the Transfer Date. The Concessionaire shall further provide such reasonable advice and assistance as the Authority, its concessionaire or agent may reasonably require for operation of the Project until the expiry of 6 (six) months after the Transfer Date.

32.3.3 The Authority shall have the option to purchase or hire from the Concessionaire at a fair market value and free from any encumbrance all or any part of the plant and machinery used in connection with the Project but which does not form part of the assets specified in Clause 32.1.1 and is reasonably required in connection with operation of the Project. For the avoidance of doubt, in the event of dispute or difference relating to fair market value, the Dispute Resolution Procedure shall apply.

32.4 Vesting Certificate

The divestment of all rights, title and interest in the Project shall be deemed to be complete on the date when all of the Divestment Requirements have been fulfilled, and the Authority shall, without unreasonable delay, thereupon issue a certificate substantially in the form set forth in Schedule-Q (the "Vesting Certificate"), which will have the effect of constituting evidence of divestment by the Concessionaire of all of its rights, title and interest in the Project, and their vesting in the Authority pursuant hereto. It is expressly agreed that any defect or deficiency in the Divestment Requirements shall not in any manner be construed or interpreted as restricting the exercise of any rights by the Authority or its nominee on, or in respect of, the Project on



the footing that all Divestment Requirements have been complied with by the Concessionaire.

32.5 Divestment costs etc.

32.5.1 The Concessionaire shall bear and pay all costs incidental to divestment of all of the rights, title and interest of the Concessionaire in the Project Assets in favor of the Authority upon Termination, save and except that all stamp duties payable on any deeds or Documents executed by the Concessionaire in connection with such Divestment shall be borne by the Authority.

32.5.2 In the event of any Dispute relating to matters covered by and under this Article 32, the Dispute Resolution Procedure shall apply.



ARTICLE 33

DEFECTS LIABILITY AFTER TERMINATION

33.1 Liability for defects after Termination

The Concessionaire shall be responsible for all defects and deficiencies in the Project for a period of 120 (one hundred and twenty) days after Termination, and it shall have the obligation to repair or rectify, at its own cost, all defects and deficiencies observed by the Independent Engineer in the Project during the aforesaid period. In the event that the Concessionaire fails to repair or rectify such defect or deficiency within a period of 15 (fifteen) days from the date of notice issued by the Authority in this behalf, the Authority shall be entitled to get the same repaired or rectified at the Concessionaire's risk and cost so as to make the Project conform to the Maintenance Requirements. All costs incurred by the Authority hereunder shall be reimbursed by the Concessionaire to the Authority within 15 (fifteen) days of receipt of demand thereof, and in the event of default in reimbursing such costs, the Authority shall be entitled to recover the same from the funds retained in the Escrow Account under the provisions of Clause 33.2 or from the Performance Guarantee provided thereunder. For the avoidance of doubt, the provisions of this Article 33 shall not apply if Termination occurs prior to COD.

33.2 Retention in Escrow Account

33.2.1 Notwithstanding anything to the contrary contained in this Agreement, but subject to the provisions of Clause 33.2.3, a sum equal to 15% (fifteen per cent) of the Annuity Payment due and payable immediately preceding the Transfer Date shall be retained in the Escrow Account for a period of 120 (one hundred and twenty) days after Termination for meeting the liabilities, if any, arising out of or in connection with the provisions of Clause 33.1.

33.2.2 Without prejudice to the provisions of Clause 33.2.1, the Independent Engineer shall carry out an inspection of the Project at any time between 210 (two hundred and ten) and 180 (one hundred and eighty) days prior to the Termination and if it recommends that the status of the Project is such that a sum larger than the amount stipulated in Clause 33.2.1 should be retained in the Escrow Account and for a period longer than the aforesaid 120 (one hundred and twenty) days, the amount recommended by the Independent Engineer shall be retained in the Escrow Account for the period specified by it.

33.2.3 The Concessionaire may, for the performance of its obligations under this Article 33, provide to the Authority a guarantee from a Bank for a sum equivalent to the amount determined under Clause 33.2.1 or 33.2.2, as the case may be, and for the period specified therein, substantially in the form set forth in Schedule-F (the "Performance Guarantee"), to be modified, mutatis mutandis, for this purpose, and the Authority shall, without prejudice to its other rights and remedies hereunder or in law, be entitled to encash and appropriate the required amounts from the Performance Guarantee for undertaking the repairs or rectification at the Concessionaire's risk and cost in accordance with the provisions of this Article 33. Upon furnishing of a Performance Guarantee under this Clause 33.2.3, the retention of funds in the Escrow Account in terms of Clause 33.2.1 or 33.2.2, as the case may be, shall be dispensed with.

Part VI

Other Provisions

Four laning of NH-163 from Hyderabad (ORR Appa Junction) (Design Km 14.000/Existing Km 14.000) to Manneguda (Design Km 60.405/Existing Km 59.500) (Design Length = 46.405 Km) in the State of Telangana under NH(O) on Hybrid Annuity Mode Page 117



ARTICLE 34

ASSIGNMENT AND CHARGES

34.1 Restrictions on assignment and charges

34.1.1 Subject to Clauses 34.2 and 34.3, this Agreement shall not be assigned by the Concessionaire to any person, save and except with the prior consent in writing of the Authority, which consent the Authority shall be entitled to decline without assigning any reason.

34.1.2 Subject to the provisions of Clause 34.2, the Concessionaire shall not create nor permit to subsist any Encumbrance, or otherwise transfer or dispose of all or any of its rights and benefits under this Agreement or any Project Agreement to which the Concessionaire is a party, except with prior consent in writing of the Authority, which consent the Authority shall be entitled to decline without assigning any reason.

34.2 Permitted assignment and charges

The restraints set forth in Clause 34.1 shall not apply to:

- (a) liens arising by operation of law (or by an agreement evidencing the same) in the ordinary course of business of the Project;
- (b) mortgages/pledges/hypothecation of goods/assets other than Project Assets and their related documents of title, arising or created in the ordinary course of business of the Project, and as security only for indebtedness to the Senior Lenders under the Financing Agreements and/or for working capital arrangements for the Project. For the avoidance of doubt, the Senior Lenders would be entitled to create a lien on the Escrow Account, subject to and without prejudice to the rights of the Authority under this Agreement;
- (c) assignment of rights, interest and obligations of the Concessionaire to or in favor of the Lenders' Representative as nominee and for the benefit of the Senior Lenders, to the extent covered by and in accordance with the Substitution Agreement as security for financing provided by Senior Lenders under the Financing Agreements; and
- (d) Liens or encumbrances required by any Applicable Law.

34.3 Substitution Agreement

34.3.1 The Lenders' Representative, on behalf of Senior Lenders, may exercise the right to substitute the Concessionaire pursuant to the agreement for substitution of the Concessionaire (the "Substitution Agreement") to be entered into amongst the Concessionaire, the Authority and the Lenders' Representative, on behalf of Senior Lenders, substantially in the form set forth in Schedule-R.

34.3.2 Upon substitution of the Concessionaire under and in accordance with the Substitution Agreement, the Nominated Company substituting the Concessionaire shall be deemed to be the Concessionaire under this Agreement and shall enjoy all rights and be responsible for all obligations of the Concessionaire under this Agreement as if it were



the Concessionaire; provided that where the Concessionaire is in breach of this Agreement on the date of such substitution, the Authority shall by notice grant a Cure Period of 120 (one hundred and twenty) days to the Concessionaire for curing such breach.

34.4 Assignment by the Authority

Notwithstanding anything to the contrary contained in this Agreement, the Authority may, after giving 60 (sixty) days' notice to the Concessionaire, assign and/ or transfer any of its rights and benefits and/or obligations under this Agreement to an assignee who is, in the reasonable opinion of the Authority, capable of fulfilling all of the Authority's then outstanding obligations under this Agreement.



ARTICLE 35
CHANGE IN LAW

35.1 Increase in costs

If as a result of Change in Law, the Concessionaire suffers an increase in costs or reduction in net after-tax return or other financial burden, the aggregate financial effect of which exceeds the higher of Rs. 1.51 crore (Rupees One Crore and Fifty One lakh only) or 2% (two per cent) of the total Annuity Payments in any Accounting Year, the Concessionaire may so notify the Authority and propose amendments to this Agreement so as to place the Concessionaire in the same financial position as it would have enjoyed had there been no such Change in Law resulting in increased costs, reduction in return or other financial burden as aforesaid. Upon notice by the Concessionaire, the Parties shall meet, as soon as reasonably practicable as but no later than 30 (thirty) days from the date of notice and either agree on amendments to this Agreement or on any other mutually agreed arrangement:

Provided that if no agreement is reached within 90 (ninety) days of the aforesaid notice, the Concessionaire may by notice require the Authority to pay an amount that would place the Concessionaire in the same financial position that it would have enjoyed had there been no such Change in Law, and within 15 (fifteen) days of receipt of such notice, along with particulars thereof, the Authority shall pay the amount specified therein; provided that if the Authority shall dispute such claim of the Concessionaire, the same shall be settled in accordance with the Dispute Resolution Procedure. For the avoidance of doubt, it is agreed that this Clause 35.1 shall be restricted to changes in law directly affecting the Concessionaire's costs of performing its obligations under this Agreement.

35.2 Reduction in costs

If as a result of Change in Law, the Concessionaire benefits from a reduction in costs or increase in net after-tax return or other financial gains, the aggregate financial effect of which exceeds the higher of Rs. 1.51 crore (Rupees One Crore and Fifty One lakh only) or 2% (two per cent) of the total Annuity Payments in any Accounting Year, the Authority may so notify the Concessionaire and propose amendments to this Agreement so as to place the Concessionaire in the same financial position as it would have enjoyed had there been no such Change in Law resulting in decreased costs, increase in return or other financial gains as aforesaid. Upon notice by the Authority, the Parties shall meet, as soon as reasonably practicable as but no later than 30 (thirty) days from the date of notice and either agree on such amendments to this Agreement or on any other mutually agreed arrangement:

Provided that if no agreement is reached within 90 (ninety) days of the aforesaid notice, the Authority may by notice require the Concessionaire to pay an amount that would place the Concessionaire in the same financial position that it would have enjoyed had there been no such Change in Law, and within 15 (fifteen) days of receipt of such notice, along with particulars thereof, the Concessionaire shall pay the amount specified therein to the Authority; provided that if the Concessionaire shall dispute such claim of the



Authority, the same shall be settled in accordance with the Dispute Resolution Procedure. For the avoidance of doubt, it is agreed that this Clause 35.2 shall be restricted to changes in law directly affecting the Concessionaire's costs of performing its obligations under this Agreement.

35.3 Protection of NPV

Pursuant to the provisions of Clauses 35.1 and 35.2 and for the purposes of placing the Concessionaire in the same financial position as it would have enjoyed had there been no Change in Law affecting the costs, returns or other financial burden or gains, the Parties shall rely on the Financial Model to establish a net present value (the "NPV") of the net cash flow and make necessary adjustments in costs, revenues, compensation or other relevant parameters, as the case may be, to procure that the NPV of the net cash flow is the same as it would have been if no Change in Law had occurred. For the avoidance of doubt, the Parties expressly agree that for determination of NPV, the discount rate to be used shall be equal to the weighted average rate of interest at which the Concessionaire has raised the Debt Due under its Financing Agreements.

35.4 Restriction on cash compensation

The Parties acknowledge and agree that the demand for cash compensation under this Article 35 shall be restricted to the effect of Change in Law during the respective Accounting Year and shall be made at any time after commencement of such year, but no later than one year from the close of such Accounting Year. Any demand for cash compensation payable for and in respect of any subsequent Accounting Year shall be made after the commencement of the Accounting Year to which the demand pertains, but no later than 2 (two) years from the close of such Accounting Year.

35.5 Deleted



ARTICLE 36

LIABILITY AND INDEMNITY

36.1 General indemnity

36.1.1 The Concessionaire shall indemnify, defend, save and hold harmless the Authority and its officers, servants, agents, Government Instrumentalities and Government owned and/or controlled entities/enterprises, (the “**Authority Indemnified Persons**”) against any and all suits, proceedings, actions, demands and claims from third parties for any loss, damage, cost and expense of whatever kind and nature, whether arising out of any breach by the Concessionaire of any of its obligations under this Agreement or any related agreement or on account of any defect or deficiency in the provision of services by the Concessionaire to the Authority or to any User, or from any negligence of the Concessionaire under contract or tort or on any other ground whatsoever, except to the extent that any such suits, proceedings, actions, demands and claims have arisen due to any negligent act or omission, or breach or default of this Agreement on the part of the Authority Indemnified Persons.

36.1.2 The Authority shall indemnify, defend, save and hold harmless the Concessionaire against any and all suits, proceedings, actions, demands and claims from third parties for any loss, damage, cost and expense of whatever kind and nature arising out of (a) defect in title and/or the rights of the Authority in the land comprised in the Site, and/or (b) breach by the Authority of any of its obligations under this Agreement or any related agreement, which materially and adversely affect the performance by the Concessionaire of its obligations under this Agreement, save and except that where any such claim, suit, proceeding, action, and/or demand has arisen due to a negligent act or omission, or breach of any of its obligations under any provision of this Agreement or any related agreement, and/or breach of its statutory duty on the part of the Concessionaire, its subsidiaries, affiliates, contractors, servants or agents, the same shall be the liability of the Concessionaire.

36.2 Indemnity by the Concessionaire

36.2.1 Without limiting the generality of Clause 36.1, the Concessionaire shall fully indemnify, hold harmless and defend the Authority and the Authority Indemnified Persons from and against any and all loss and/or damages arising out of or with respect to:

- (a) Failure of the Concessionaire to comply with Applicable Laws and Applicable Permits;
- (b) Payment of taxes required to be made by the Concessionaire in respect of the income or other taxes of the Concessionaire’s contractors, suppliers and representatives; or
- (c) Non-payment of amounts due as a result of materials or services furnished to the Concessionaire or any of its contractors which are payable by the Concessionaire or any of its contractors.



36.2.2 Without limiting the generality of the provisions of this Article 36, the Concessionaire shall fully indemnify, hold harmless and defend the Authority Indemnified Persons from and against any and all suits, proceedings, actions, claims, demands, liabilities and damages which the Authority Indemnified Persons may hereafter suffer, or pay by reason of any demands, claims, suits or proceedings arising out of claims of infringement of any domestic or foreign patent rights, copyrights or other intellectual property, proprietary or confidentiality rights with respect to any materials, information, design or process used by the Concessionaire or by the Concessionaire's Contractors in performing the Concessionaire's obligations or in any way incorporated in or related to the Project. If in any such suit, action, claim or proceedings, a temporary restraint order or preliminary injunction is granted, the Concessionaire shall make every reasonable effort, by giving a satisfactory bond or otherwise, to secure the revocation or suspension of the injunction or restraint order. If, in any such suit, action, claim or proceedings, the Project, or any part thereof or comprised therein, is held to constitute an infringement and its use is permanently enjoined, the Concessionaire shall promptly make every reasonable effort to secure for the Authority a license, at no cost to the Authority, authorizing continued use of the infringing work. If the Concessionaire is unable to secure such license within a reasonable time, the Concessionaire shall, at its own expense, and without impairing the Specifications and Standards, either replace the affected work, or part, or process thereof with non-infringing work or part or process, or modify the same so that it becomes non-infringing.

36.3 Notice and contest of claims

In the event that either Party receives a claim or demand from a third party in respect of which it is entitled to the benefit of an indemnity under this Article 36 (the "**Indemnified Party**") it shall notify the other Party (the "**Indemnifying Party**") within 15 (fifteen) days of receipt of the claim or demand and shall not settle or pay the claim without the prior approval of the Indemnifying Party, which approval shall not be unreasonably withheld or delayed. In the event that the Indemnifying Party wishes to contest or dispute the claim or demand, it may conduct the proceedings in the name of the Indemnified Party, subject to the Indemnified Party being secured against any costs involved, to its reasonable satisfaction.

36.4 Defense of claims

36.4.1 The Indemnified Party shall have the right, but not the obligation, to contest, defend and litigate any claim, action, suit or proceeding by any third party alleged or asserted against such Party in respect of, resulting from, related to or arising out of any matter for which it is entitled to be indemnified hereunder, and reasonable costs and expenses thereof shall be indemnified by the Indemnifying Party. If the Indemnifying Party acknowledges in writing its obligation to indemnify the Indemnified Party in respect of loss to the full extent provided by this Article 36, the Indemnifying Party shall be entitled, at its option, to assume and control the defense of such claim, action, suit or proceeding, liabilities, payments and obligations at its expense and through the counsel of its choice; provided it gives prompt notice of its intention to do so to the Indemnified Party and reimburses the Indemnified Party for the reasonable cost and expenses

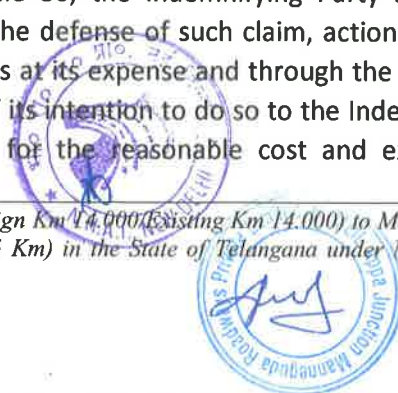

incurred by the Indemnified Party prior to the assumption by the Indemnifying Party of such defense. The Indemnifying Party shall not be entitled to settle or compromise any claim, demand, action, suit or proceeding without the prior written consent of the Indemnified Party, unless the Indemnifying Party provides such security to the Indemnified Party as shall be reasonably required by the Indemnified Party to secure the loss to be indemnified hereunder to the extent so compromised or settled.

36.4.2 If the Indemnifying Party has exercised its rights under Clause 36.3, the Indemnified Party shall not be entitled to settle or compromise any claim, action, suit or proceeding without the prior written consent of the Indemnifying Party (which consent shall not be unreasonably withheld or delayed).

36.4.3 If the Indemnifying Party exercises its rights under Clause 36.3, the Indemnified Party shall nevertheless have the right to employ its own counsel, and such counsel may participate in such action, but the fees and expenses of such counsel shall be at the expense of the Indemnified Party, when and as incurred, unless:

- (a) The employment of counsel by such party has been authorized in writing by the Indemnifying Party;
- (b) The Indemnified Party shall have reasonably concluded that there may be a conflict of interest between the Indemnifying Party and the Indemnified Party in the conduct of the defense of such action;
- (c) the Indemnifying Party shall not, in fact, have employed independent counsel reasonably satisfactory to the Indemnified Party, to assume the defense of such action and shall have been so notified by the Indemnified Party; or
- (d) The Indemnified Party shall have reasonably concluded and specifically notified the Indemnifying Party either:
 - (i) that there may be specific defenses available to it which are different from or additional to those available to the Indemnifying Party; or
 - (ii) That such claim, action, suit or proceeding involves or could have a material adverse effect upon it beyond the scope of this Agreement:

Provided that if Sub-clauses (b), (c) or (d) of this Clause 36.4.3 shall be applicable, the counsel for the Indemnified Party shall have the right to direct the defense of such claim, demand, action, suit or proceeding on behalf of the Indemnified Party, and the reasonable fees and disbursements of such counsel shall constitute legal or other expenses hereunder.

36.5 No consequential claims

Notwithstanding anything to the contrary contained in this Article 36, the indemnities herein provided shall not include any claim or recovery in respect of any cost, expense, loss or damage of an indirect, incidental or consequential nature, including loss of profit, except as expressly provided in this Agreement.

36.6 Survival on Termination

The provisions of this Article 36 shall survive Termination.



ARTICLE 37

RIGHTS AND TITLE OVER THE SITE

37.1 Licensee rights

For the purpose of this Agreement, the Concessionaire shall have rights to the use of the Site as a licensee subject to and in accordance with this Agreement, and to this end; it may regulate the entry and use of the Project by third parties in accordance with and subject to the provisions of this Agreement.

37.2 Access rights of the Authority and others

37.2.1 The Concessionaire shall allow free access to the Site at all times for the authorized representatives and vehicles of the Authority and/or its contractors, Senior Lenders, and the Independent Engineer, and for the persons and vehicles duly authorized by any Government Instrumentality to inspect the Project and to investigate any matter within their authority, and upon reasonable notice, the Concessionaire shall provide to such persons reasonable assistance necessary to carry out their respective duties and functions.

37.2.2 The Concessionaire shall, for the purpose of operation and maintenance of any utility or road specified in Article 11, allow free access to the Site at all times for the authorized persons and vehicles of the controlling body of such utility or road.

37.3 Property taxes

All property taxes on the Site shall be payable by the Authority as owner of the Site; provided, however, that any such taxes payable by the Concessionaire under Applicable Laws for use of the Site shall not be reimbursed or payable by the Authority. For the avoidance of doubt, the Parties agree that stamp duties, if any, due and payable on the grant of license comprising this Agreement shall be paid by the Authority. Provided, however, that the Authority may require the Concessionaire to pay such stamp duties, which shall be reimbursed by the Authority to the Concessionaire within 15 (fifteen) days of receiving the demand thereof.

37.4 Restriction on sub-letting

The Concessionaire shall not sub-license or sub-let the whole or any part of the Site, save and except as may be expressly set forth in this Agreement; provided that nothing contained herein shall be construed or interpreted as restricting the right of the Concessionaire to appoint Contractors for the performance of its obligations hereunder including for operation and maintenance of all or any part of the Project.



ARTICLE 38

DISPUTE RESOLUTION

38.1 Dispute Resolution

38.1.1 In the event of any dispute, difference or controversy of whatever nature howsoever arising under or out of or in relation to this Agreement (including its interpretation) between the Parties, and so notified in writing by either Party to the other Party (the "Dispute") either Party may call upon the Independent Engineer, to mediate and assist the Parties in arriving at an amicable settlement thereof.

38.1.2 The Parties agree to use their best efforts for resolving all Disputes arising under or in respect of this Agreement promptly, equitably and in good faith, and further agree to provide each other with reasonable access during normal business hours to all non-privileged records, information and data pertaining to any Dispute.

38.1.3 Dispute Resolution Board (DRB):

Failing mediation by the Independent Engineer or without the intervention of the Independent Engineer, either Party may require such Dispute to be referred to the Dispute Resolution Board ("DRB") in accordance with the procedure set forth in Schedule-S to the Concession Agreement. The decision(s) of the Dispute Resolution Board shall be binding on both parties who shall promptly give effect to unless and until the same is revised/modified, as hereinafter provided, in a Conciliation/Arbitral Tribunal.

38.2 Conciliation

If either the Authority or the Concessionaire is dissatisfied with any decision of the DRB, and/ or if the DRB is unable to resolve the dispute, either Party may refer the Dispute to arbitration in accordance with the provisions of Clause 38.3 but before resorting to such arbitration, the parties agree to explore conciliation by the Conciliation Committees of Independent Experts set up by the Authority in accordance with the procedure decided by the panel of such experts and notified by the Authority on its website including its subsequent amendments. In the event of the conciliation proceedings being successful, the parties to the dispute would sign the written settlement agreement and the conciliators would authenticate the same. Such settlement agreement would then be binding on the parties in terms of Section 73 of the Arbitration Act. In case of failure of the conciliation process even at the level of the Conciliation Committee, either party may refer the Dispute to arbitration in accordance with the provisions of Clause 38.3.

38.3 Arbitration

38.3.1 Any Dispute which is not resolved amicably by conciliation as provided in Clause 38.2 shall be finally settled by arbitration as set forth below:

- i) The Dispute shall be finally referred to Society for Affordable Resolution of Disputes (hereinafter called as SAROD), a Society registered under Society's Act, 1860 vide Registration no. S/RS/SW1049/2013 duly represented by Authority and National Highways Builders Federation (NHBF). The dispute shall be dealt with in



terms of Rules of SAROD. The detailed procedure for conducting Arbitration shall be governed by the Rules of SAROD and provisions of Arbitration & Conciliation Act, 1996, as amended from time to time. The Dispute shall be governed by Substantive Law of India.

- ii) The appointment of Tribunal, Code of conduct for Arbitrators and fees and expenses of SAROD and Arbitral Tribunal shall also be governed by the Rules of SAROD as amended from time to time.
- iii) Subject to the provisions of THE LIMITATION ACT, 1963, as amended from time to time, Arbitration may be commenced during or after the Concession Period, provided that the obligations of Authority and the Concessionaire shall not be altered by reason of the Arbitration being conducted during the Concession Period.
- iv) The venue of Arbitration shall be New Delhi or a place selected by governing body of SAROD and the language for all documents and communications between the parties shall be English.

The expenses incurred by each party in connection with the preparation, presentation, etc., of arbitral proceedings shall be shared by each party itself.

38.3.2 The arbitrators shall make a reasoned award (the "Award"). Any Award made in any arbitration held pursuant to this Article 38 shall be final and binding on the Parties as from the date it is made, and the Concessionaire and the Authority agree and undertake to carry out such Award without delay.

38.3.3 The Concessionaire and the Authority agree that an Award may be enforced against the Concessionaire and/or the Authority, as the case may be, and their respective assets wherever situated.

38.3.4 This Agreement and the rights and obligations of the Parties shall remain in full force and effect, pending the Award in any arbitration proceedings hereunder. Further, the parties unconditionally acknowledge and agree that notwithstanding any dispute between them, each party shall proceed with the performance of its respective obligations, pending resolution of Dispute in accordance with this Article.

38.4 Adjudication by Regulatory Authority, Tribunal or Commission

In the event of constitution of a statutory regulatory authority, tribunal or commission, as the case may be, with powers to adjudicate upon disputes between the Concessionaire and the Authority, all Disputes arising after such constitution shall, instead of reference to arbitration under Clause 38.3, be adjudicated upon by such regulatory authority, tribunal or commission in accordance with the Applicable Law and all references to Dispute Resolution Procedure shall be construed accordingly. For the avoidance of doubt, the Parties hereto agree that the adjudication hereunder shall not be final and binding until an appeal against such adjudication has been decided by an appellate tribunal or court of competent jurisdiction, as the case may be, or no such appeal has been preferred within the time specified in the Applicable Law.



ARTICLE 39

DISCLOSURE

39.1 Disclosure of Specified Documents

The Concessionaire shall make available for inspection by any person, copies of this Concession Agreement, the Maintenance Manual, the Maintenance Program, the Maintenance Requirements and the Safety Requirements (hereinafter collectively referred to as the “**Specified Documents**”), free of charge, during normal business hours on all working days at the Site and the Concessionaire’s Registered Office. The Concessionaire shall prominently display at the Site, public notices stating the availability of the Specified Documents for such inspection, and shall provide copies of the same to any person upon payment of copying charges on a ‘no profit no loss’ basis.

39.2 Disclosure of Documents relating to safety

The Concessionaire shall make available for inspection by any person copies of all Documents and data relating to safety of the Project, free of charge, during normal business hours on all working days, at the Concessionaire’s Registered Office. The Concessionaire shall make copies of the same available to any person upon payment of copying charges on a ‘no profit no loss’ basis.

39.3 Notwithstanding the provisions of Clauses 39.1 and 39.2, the Authority shall be entitled to direct the Concessionaire, from time to time, to withhold the disclosure of Protected Documents (as defined herein below) to any person in pursuance of the aforesaid Clauses.

Explanation:

The expression Protected Documents shall mean such of the Specified Documents or documents referred to in Clauses 39.1 and 39.2, or portions thereof, the disclosure of which the Authority is entitled to withhold under the provisions of the Right to Information Act, 2005.

ARTICLE 40

REDRESSAL OF PUBLIC GRIEVANCES

40.1 Complaints Register

- 40.1.1 The Concessionaire shall maintain a public relations office at the Site where it shall keep a register (the “**Complaint Register**”) open to public access at all times for recording of complaints by any person (the “**Complainant**”). Information relating to the availability of and access to the Complaint Register shall be prominently displayed by the Concessionaire at each the Site so as to bring it to the attention of all Users.
- 40.1.2 The Complaint Register shall be securely bound and each page thereof shall be duly numbered. It shall have appropriate columns including the complaint number, date, name and address of the Complainant, substance of the complaint and the action taken by the Concessionaire. Immediately after a complaint is registered, the Concessionaire shall give a receipt to the Complainant stating the date and complaint number.
- 40.1.3 Without prejudice to the provisions of Clauses 40.1.1 and 40.1.2, the Authority may, in consultation with the Concessionaire, specify the procedure for making complaints in electronic form and for responses thereto.

40.2 Redressal of complaints

- 40.2.1 The Concessionaire shall inspect the Complaint Register every day and take prompt and reasonable action for redressed of each complaint. The action taken shall be briefly noted in the Complaint Register and a reply stating the particulars thereof shall be sent by the Concessionaire to the Complainant under a certificate of posting.
- 40.2.2 Within 7 (seven) days of the close of each month, the Concessionaire shall send to the Authority and to the Independent Engineer a true photocopy each of all the pages of the Complaint Register on which any entry has been recorded during the course of such month, and upon perusal thereof, the Authority may, in its discretion, advise the Concessionaire to take such further action as the Authority may deem appropriate for a fair and just redressal of any grievance. The Concessionaire shall consider such advice and inform the Authority of its decision thereon, and if the Authority is of the opinion that the Complainant is entitled to further relief, the Authority may advise the Complainant to seek appropriate remedy under the Consumer Protection Act, 1986, at his own risk and cost.

ARTICLE 41

MISCELLANEOUS

41.1 Governing law and jurisdiction

This Agreement shall be construed and interpreted in accordance with and governed by the laws of India, and the courts in New Delhi shall have exclusive jurisdiction over matters arising out of or relating to this Agreement.

41.2 Waiver of immunity

Each Party unconditionally and irrevocably:

- (a) Agrees that the execution, delivery and performance by it of this Agreement constitute commercial acts done and performed for commercial purpose;
- (b) agrees that, should any proceedings be brought against it or its assets, property or revenues in any jurisdiction in relation to this Agreement or any transaction contemplated by this Agreement, no immunity (whether by reason of sovereignty or otherwise) from such proceedings shall be claimed by or on behalf of the Party with respect to its assets;
- (c) waives any right of immunity which it or its assets, property or revenues now has, may acquire in the future or which may be attributed to it in any jurisdiction; and
- (d) consents generally in respect of the enforcement of any judgment or award against it in any such proceedings to the giving of any relief or the issue of any process in any jurisdiction in connection with such proceedings (including the making, enforcement or execution against it or in respect of any assets, property or revenues whatsoever irrespective of their use or intended use of any order or judgment that may be made or given in connection therewith).

41.3 Depreciation

For the purposes of depreciation under Applicable Laws, the property representing the capital investment made by the Concessionaire in the Project shall be deemed to be acquired and owned by the Concessionaire. For the avoidance of doubt, the Authority shall not in any manner be liable in respect of any claims for depreciation to be made by the Concessionaire under Applicable Laws.

41.4 Delayed payments

- 41.4.1 The Parties hereto agree that payments due from one Party to the other Party under the provisions of this Agreement shall be made within the period set forth therein, and if no such period is specified, within 30 (thirty) days of receiving a demand along with the necessary particulars. Unless otherwise specified in this Agreement, in the event of delay beyond such period, the defaulting Party shall pay interest for the period of delay calculated at a rate equal to 4% (four per cent) above the daily average Bank Rate, and

recovery thereof shall be without prejudice to the rights of the Parties under this Agreement including Termination thereof.

41.4.2 Unless otherwise specified, any interest payable under this Agreement shall accrue on a daily outstanding basis and shall be compounded on the basis of quarterly rests.

41.5 Waiver

41.5.1 Waiver, including partial or conditional waiver, by either Party of any default by the other Party in the observance and performance of any provision of or obligations under this Agreement:

- (a) Shall not operate or be construed as a waiver of any other or subsequent default hereof or of other provisions of or obligations under this Agreement;
- (b) Shall not be effective unless it is in writing and executed by a duly authorized representative of the Party; and
- (c) Shall not affect the validity or enforceability of this Agreement in any manner.

41.5.2 Neither the failure by either Party to insist on any occasion upon the performance of the terms, conditions and provisions of this Agreement or any obligation thereunder nor time or other indulgence granted by a Party to the other Party shall be treated or deemed as waiver of such breach or acceptance of any variation or the relinquishment of any such right hereunder.

41.6 Liability for review of Documents and Drawings

Except to the extent expressly provided in this Agreement

- (a) no review, comment or approval by the Authority or the Independent Engineer of any Project Agreement, Document or Drawing submitted by the Concessionaire nor any observation or inspection of the construction, operation or maintenance of the Project nor the failure to review, approve, comment, observe or inspect hereunder shall relieve or absolve the Concessionaire from its obligations, duties and liabilities under this Agreement, Applicable Laws and Applicable Permits; and
- (b) The Authority shall not be liable to the Concessionaire by reason of any review, comment, approval, observation or inspection referred to in Sub-clause (a) above.

41.7 Exclusion of implied warranties etc.

This Agreement expressly excludes any warranty, condition or other undertaking implied at law or by custom or otherwise arising out of any other agreement between the Parties or any representation by either Party not contained in a binding legal agreement executed by both Parties.

41.8 Survival

41.8.1 Termination shall:



- (a) Not relieve the Concessionaire or the Authority, as the case may be, of any obligations hereunder which expressly or by implication survive Termination hereof; and
- (b) except as otherwise provided in any provision of this Agreement expressly limiting the liability of either Party, not relieve either Party of any obligations or liabilities for loss or damage to the other Party arising out of, or caused by, acts or omissions of such Party prior to the effectiveness of such Termination or arising out of such Termination.

41.8.2 All obligations surviving Termination shall only survive for a period of 3 (three) years following the date of such Termination.

41.9 Entire Agreement

This Agreement and the Schedules together constitute a complete and exclusive statement of the terms of the agreement between the Parties on the subject hereof, and no amendment or modification hereto shall be valid and effective unless such modification or amendment is agreed to in writing by the Parties and duly executed by persons especially empowered in this behalf by the respective Parties. All prior written or oral understandings, offers or other communications of every kind pertaining to this Agreement are abrogated and withdrawn. For the avoidance of doubt, the Parties hereto agree that any obligations of the Concessionaire arising from the Request for Proposals, as the case may be, shall be deemed to form part of this Agreement and treated as such.

41.10 Severability

If for any reason whatsoever, any provision of this Agreement is or becomes invalid, illegal or unenforceable or is declared by any court of competent jurisdiction or any other instrumentality to be invalid, illegal or unenforceable, the validity, legality or enforceability of the remaining provisions shall not be affected in any manner, and the Parties will negotiate in good faith with a view to agreeing to one or more provisions which may be substituted for such invalid, unenforceable or illegal provisions, as nearly as is practicable to such invalid, illegal or unenforceable provision. Failure to agree upon any such provisions shall not be subject to the Dispute Resolution Procedure set forth under this Agreement or otherwise.

41.11 No partnership

This Agreement shall not be interpreted or construed to create an association, joint venture or partnership between the Parties, or to impose any partnership obligation or liability upon either Party, and neither Party shall have any right, power or authority to enter into any agreement or undertaking for, or act on behalf of, or to act as or be an agent or representative of, or to otherwise bind, the other Party.

41.12 Third parties

This Agreement is intended solely for the benefit of the Parties and their respective successors and permitted assigns, and nothing in this Agreement shall be construed to

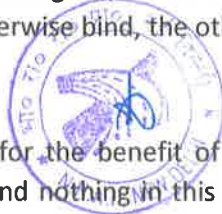

create any duty to, standard of care with reference to, or any liability to, any person not a Party to this Agreement including any Concessionaire's Contractor.

41.13 Successors and assigns

This Agreement shall be binding upon, and inure to the benefit of the Parties and their respective successors and permitted assigns.

41.14 Notices

Unless the law requires to follow the specified mode of communication only as prescribed therein, any notice or other communication to be given by one contracting party to the other Party under or in connection with the matters contemplated by this Agreement shall be routed through NHA Data Lake under the hand of the authorized representative and shall:

- (a) In the case of the Concessionaire, be given through NHA Data Lake and marked for attention of the person set out below or to such other person as the Concessionaire may from time to time designate by notice to the Authority.

Attention: K. Raja Ravindra Babu
Designation: Authorised Signatory
Address: Unit 22, Technocrat Industrial Estate,
Bala Nagar, Hyderabad,
Rangareddi, Telangana, India-500033
Ph. No. +91-40- 44338700
E-mail: vmr@mailgroup.com;

- (b) In the case of the Authority, be given through NHA Data Lake and be addressed to the person named below with a copy delivered to the Authority representative or such other person as the Authority may from time to time designate by notice to the Concessionaire.

Name: Ajay Singh Bargoti
Designation: General Manager (T),
Address: National Highways Authority of India
G-5 & 6, Sector 10, Dwarka
New Delhi – 110 075, India
Ph. No. 011-25074200/100 (Ext. 1409)
E-mail: ajaybargoti@nhai.org ;

and

- (c) Any notice or communication by once contracting Party to the other Party, given in accordance herewith, shall be deemed to have been delivered when given through or made on the NHA Data Lake.

41.15 Language

Four laning of NH-163 from Hyderabad (ORR Appa Junction) (Design Km 14.000/Existing Km 14.000) to Manneguda (Design Km 60.405/Existing Km 59.500) (Design Length = 46.405 Km) in the State of Telangana under NH(O) on Hybrid Annuity Mode Page 133



All notices required to be given by one Party to the other Party and all other communications, Documentation and proceedings which are in any way relevant to this Agreement shall be in writing and in English language.

41.16 Counterparts

This Agreement may be executed in two counterparts, each of which, when executed and delivered, shall constitute an original of this Agreement.

41.17 State Support Agreement

The Concessionaire acknowledges that it has received from the Authority a certified true copy of the agreement executed between MORTH and the State Government for providing the support and services specified therein (the “**State Support Agreement**”), and the Parties hereto agree to make their best endeavors to procure the support of the State Government.



ARTICLE 42 DEFINITIONS

42.1 Definitions

In this Agreement, the following words and expressions shall, unless repugnant to the context or meaning thereof, have the meaning hereinafter respectively assigned to them:

“Accounting Year” means the financial year commencing from the first day of April of any calendar year and ending on the thirty-first day of March of the next calendar year;

“Additional Performance Security” shall have the meaning as set forth in Clause 9.7;

“Adjusted Equity” means the Equity funded in Indian Rupees and adjusted on the first day of the current month (the **“Reference Date”**), in the manner set forth below, to reflect the change in its value on account of depreciation and variations in WPI, and for any Reference Date occurring:

- (a) on or before COD, the Adjusted Equity shall be a sum equal to the Equity funded in Indian Rupees and expended on the Project, revised to the extent of one half of the variation in WPI occurring between the first day of the month of Appointed Date and the Reference Date;

“Affected Party” shall have the meaning as set forth in Clause 28.1;

“Agreement” or **“Concession Agreement”** means this Agreement, its Recitals, and the Schedules hereto and any amendments thereto made in accordance with the provisions contained in this Agreement;

“Annuity Payments” shall have the meaning as set forth in Clause 23.6.2;

“Annuity Payment Date” shall have the meaning as set forth in Clause 23.6.2;

“Appendix” shall have the meaning as set forth in Clause 10.3.1;

“Applicable Laws” means all laws, brought into force and effect by GOI or the State Government including rules, regulations and notifications made thereunder, and judgments, decrees, injunctions, writs and orders of any court of record, applicable to this Agreement and the exercise, performance and discharge of the respective rights and obligations of the Parties hereunder, as may be in force and effect during the subsistence of this Agreement;

“Applicable Permits” means all clearances, licenses, permits, authorizations, no objection certificates, consents, approvals and exemptions required to be obtained or maintained under Applicable Laws in connection with the construction, operation and maintenance of the Project during the subsistence of this Agreement;

“Appointed Date” means the date on which Financial Close is achieved and every Condition Precedent is satisfied, in accordance with the provisions of this Agreement, and such date shall be the date of commencement of the Concession Period;



“Associate” or “Affiliate” means, in relation to either Party {and/or Consortium Members}, a person who controls, is controlled by, or is under the common control with such Party {or Consortium Member} (as used in this definition, the expression “control” means, with respect to a person which is a company or corporation, the ownership, directly or indirectly, of more than 50% (fifty per cent) of the voting shares of such person, and with respect to a person which is not a company or corporation, the power to direct the management and Policies of such person, whether by operation of law or by contract or otherwise);

“Authority” shall have the meaning attributed thereto in the array of Parties as set forth in the Recitals;

“Authority Default” shall have the meaning as set forth in Clause 31.2.1;

“Authority Indemnified Persons” shall have the meaning set forth in Clause 36.1.1;

“Authority Representative” means such person or persons as may be authorized in writing by the Authority to act on its behalf under this Agreement and shall include any person or persons having authority to exercise any rights or perform and fulfill any obligations of the Authority under this Agreement;

“Bank” means a bank incorporated in India and having a minimum net worth of Rs. 1,000 crore (Rupees one thousand crore) or any other bank acceptable to Senior Lenders, but does not include a bank in which any Senior Lender has an interest;

“Bank Rate” means the rate of interest specified by the Reserve Bank of India from time to time in pursuance of section 49 of the Reserve Bank of India Act, 1934 or any replacement of such Bank Rate for the time being in effect;

“Bid” means the documents in their entirety comprised in the bid submitted by the {selected bidder/Consortium} in response to the Request for Proposals in accordance with the provisions thereof and **“Bids”** shall mean the bids submitted by any and all pre-qualified bidders;

“Bid Date” means the last date on which the Bid may have been submitted in accordance with the provisions of the Request for Proposals;

“Bid Project Cost” shall have the meaning as set forth in Clause 23.1;

“Bid Security” Deleted;

“COD” or “Commercial Operation Date” shall have the meaning as set forth in Clause 15.1.1;

“CPI (IW)” means the Consumer Price Index for Industrial Workers as published by the Labour Bureau, Government of India and shall include any index which substitutes the CPI (IW), and any reference to CPI (IW) shall, unless the context otherwise requires, be construed as a reference to the CPI (IW) published for the period ending with the preceding quarter;

“Change in Law” means the occurrence of any of the following after the Bid Date:

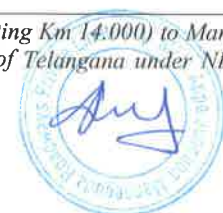

- (a) The enactment of any new Indian law;
- (b) The repeal, modification or re-enactment of any existing Indian law;
- (c) The commencement of any Indian law which has not entered into effect until the Bid Date;
- (d) a change in the interpretation or application of any Indian law by a judgment of a court of record which has become final, conclusive and binding, as compared to such interpretation or application by a court of record prior to the Bid Date; or
- (e) Any change in the rates of any of the Taxes that have a direct effect on the Project;

"Change in Ownership" means a transfer of the direct and/or indirect legal or beneficial ownership of any shares, or securities convertible into shares, that causes the aggregate holding of the {selected bidder/ Consortium Members}, together with {its/their} Associates, in the total Equity to decline below 51% (fifty one per cent) thereof during Construction Period and six months thereafter; provided that any material variation (as compared to the representations made by the Concessionaire during the bidding process for the purposes of meeting the minimum conditions of eligibility or for evaluation of its application or bid, as the case may be,) in the proportion of the equity holding of {the selected bidder/ any Consortium Member} to the total Equity, if it occurs prior to completion of a period six months after COD, shall constitute Change in Ownership;

"Change of Scope" shall have the meaning as set forth in Clause 16.1.1;

"Company" means the company acting as the Concessionaire under this Agreement;

"Completion Certificate" shall have the meaning as set forth in Clause 14.2;

"Completion Cost" shall have the meaning as set forth in Clause 23.6.1

"Concession" shall have the meaning as set forth in Clause 3.1.1;

"Concessionaire" shall have the meaning attributed thereto in the array of Parties as set forth in the Recitals;

"Concession Period" means the period starting on and from Appointed Date and ending on the Transfer Date. For avoidance of doubt it is clarified that the Concession Period shall include the Construction Period plus a fixed period of 15 years of Operation & Maintenance Period from the COD;

"Concessionaire Default" shall have the meaning as set forth in Clause 31.1.1;

"Conditions Precedent" shall have the meaning as set forth in Clause 4.1.1;

"Consortium" shall have the meaning as set forth in Recital (D) ;}

"Consortium Member" means a company specified in Recital (D) as a member of the Consortium ;}



“Construction Period” means the period beginning from the Appointed Date and ending on COD;

“Construction Works” means all works and things necessary to complete the Project in accordance with this Agreement;

“Contractor” means the person or persons, as the case may be, with whom the Concessionaire has entered into any of the EPC Contract, the O&M Contract or any other material agreement or contract for construction, operation and/or maintenance of the Project or matters incidental thereto, but does not include a person who has entered into an agreement for providing financial assistance to the Concessionaire;

“Cure Period” means the period specified in this Agreement for curing any breach or default of any provision of this Agreement by the Party responsible for such breach or default and shall:

- (a) Commence from the date on which a notice is delivered by one Party to the other Party asking the latter to cure the breach or default specified in such notice;
- (b) Not relieve any Party from liability to pay Damages or compensation under the provisions of this Agreement; and
- (c) Not in any way be extended by any period of Suspension under this Agreement;

provided that if the cure of any breach by the Concessionaire requires any reasonable action by the Concessionaire that must be approved by the Authority or the Independent Engineer hereunder, the applicable Cure Period shall be extended by the period taken by the Authority or the Independent Engineer to accord their approval;

“DBOT” or “Design, Build, Operate and Transfer” shall have the meaning as set forth in Recital (A);

“Damages” shall have the meaning as set forth in Sub-clause (w) of Clause 1.2.1;

“Debt Due” means the aggregate of the following sums expressed in Indian Rupees outstanding on the Transfer Date:

- (a) the principal amount of the debt provided by the Senior Lenders under the Financing Agreements for financing the Total Project Cost (the “principal”) but excluding any part of the principal that had fallen due for repayment two years prior to the Transfer Date;
- (b) all accrued interest, financing fees and charges payable under the Financing Agreements on, or in respect of, the debt referred to in Sub-clause (a) above until the Transfer Date but excluding (i) any interest, fees or charges that had fallen due one year prior to the Transfer Date, (ii) any penal interest or charges payable under the Financing Agreements to any Senior Lender, and (iii) any pre-payment charges in relation to accelerated repayment of debt except where such charges have arisen due to Authority Default; and



(c) any Subordinated Debt which is included in the Financial Package and disbursed by lenders for financing the Total Project Cost;

provided that if all or any part of the Debt Due is convertible into Equity at the option of Senior Lenders and/or the Concessionaire, it shall for the purposes of this Agreement be deemed to be Debt Due even after such conversion and the principal thereof shall be dealt with as if such conversion had not been undertaken;

"Debt Service" means the sum of all payments on account of principal, interest, financing fees and charges due and payable in an Accounting Year to the Senior Lenders for and in respect of Debt Due under the Financing Agreements;

"Development Period" means the period from the date of this Agreement until the Appointed Date;

"Dispute" shall have the meaning as set forth in Clause 38.1.1;

"Dispute Resolution Procedure" means the procedure for resolution of Disputes as set forth in Article 38;

"Divestment Requirements" means the obligations of the Concessionaire for and in respect of Termination as set forth in Clause 32.1;

"Document" or "Documentation" means documentation in printed or written form, or in tapes, discs, drawings, computer programmers, writings, reports, photographs, films, cassettes, or expressed in any other written, electronic, audio or visual form;

"Drawings" means all of the drawings, calculations and documents pertaining to the Project as set forth in Schedule-H, and shall include 'as built' drawings of the Project;

"EPC Contract" means the engineering, procurement and construction contract or contracts entered into by the Concessionaire with one or more Contractors for, inter alia, engineering and construction of the Project in accordance with the provisions of this Agreement;

"EPC Contractor" means the person with whom the Concessionaire has entered into an EPC Contract;

"Emergency" means a condition or situation that is likely to endanger the security of the individuals on or about the Project, including Users thereof, or which poses an immediate threat of material damage to any of the Project Assets;

"Encumbrances" means, in relation to the Project, any encumbrances such as mortgage, charge, pledge, lien, hypothecation, security interest, assignment, privilege or priority of any kind having the effect of security or other such obligations, and shall include any designation of loss payees or beneficiaries or any similar arrangement under any insurance policy pertaining to the Project, where applicable herein but excluding utilities referred to in Clause 11.1;



“Equity” means the sum expressed in Indian Rupees representing the paid up equity share capital of the Concessionaire for meeting the equity component of the Total Project Cost, and for the purposes of this Agreement shall include convertible instruments or other similar forms of capital, which shall compulsorily convert into equity share capital of the Company, and any interest-free funds advanced by any shareholder of the Company for meeting such equity component;

“Escrow Account” means an Account which the Concessionaire shall open and maintain with a Bank in which all inflows and outflows of cash on account of capital and revenue receipts and expenditures shall be credited and debited, as the case may be, in accordance with the provisions of this Agreement, and includes the Sub-Accounts of such Escrow Account;

“Escrow Agreement” shall have the meaning as set forth in Clause 25.1.2;

“Escrow Bank” shall have the meaning as set forth in Clause 25.1.1;

“Escrow Default” shall have the meaning as set forth in Schedule-O;

“Estimated Project Cost” shall be the cost estimated by the Authority for development of the Project and provided in the Request for Proposal Volume –I – Instructions to Bidders.

“Financial Close” means the fulfillment of all conditions precedent to the initial availability of funds under the Financing Agreements which shall be communicated by the Lender’s Representative to the Authority in writing. Such communication from Lender’s Representative shall be treated as date on which the Financial Close is achieved;

“Financial Default” shall have the meaning as set forth in Schedule-R;

“Financial Model” means the financial model adopted by Senior Lenders, setting forth the capital and operating costs of the Project and revenues therefrom on the basis of which financial viability of the Project has been determined by the Senior Lenders, and includes a description of the assumptions and parameters used for making calculations and projections therein;

“Financial Package” means the financing package indicating the total capital cost of the Project and the means of financing thereof, as set forth in the Financial Model and approved by the Senior Lenders, and includes Equity, all financial assistance specified in the Financing Agreements and Subordinated Debt, if any;

“Financing Agreements” means the agreements executed by the Concessionaire in respect of financial assistance to be provided by the Senior Lenders by way of loans, guarantees, subscription to non-convertible debentures and other debt instruments including loan agreements, guarantees, notes, debentures, bonds and other debt instruments, security agreements, and other documents relating to the financing (including refinancing) of the Total Project Cost, and includes amendments or modifications made in accordance with Clause 5.2.3;

“Force Majeure” or “Force Majeure Event” shall have the meaning ascribed to it in Clause 28.1;

“GOI” means the Government of India;

“Good Industry Practice” means the practices, methods, techniques, designs, standards, skills, diligence, efficiency, reliability and prudence which are generally and reasonably expected from a reasonably skilled and experienced operator engaged in the same type of undertaking as envisaged under this Agreement and which would be expected to result in the performance of its obligations by the Concessionaire in accordance with this Agreement, Applicable Laws and Applicable Permits in reliable, safe, economical and efficient manner and for providing safe, economical, reliable and efficient use of the Project;

“Government” means the Government of the India;

“Government Instrumentality” means any department, division or sub-division of the Government or the State Government and includes any commission, board, authority, agency or municipal and other local authority or statutory body, including Panchayat, under the control of the Government or the State Government, as the case may be, and having jurisdiction over all or any part of the Project or the performance of all or any of the services or obligations of the Concessionaire under or pursuant to this Agreement;

“Indemnified Party” means the Party entitled to the benefit of an indemnity pursuant to Article 36;

“Indemnifying Party” means the Party obligated to indemnify the other Party pursuant to Article 36;

“Independent Engineer” shall have the meaning as set forth in Clause 21.1;

“Indirect Political Event” shall have the meaning as set forth in Clause 28.3;

“Insurance Cover” means the aggregate of the maximum sums insured under the insurances taken out by the Concessionaire pursuant to Article 26, and includes all insurances required to be taken out by the Concessionaire under Clause 26.2 but not actually taken, and when used in the context of any act or event, it shall mean the aggregate of the maximum sums insured and payable or deemed to be insured and payable in relation to such act or event;

“Intellectual Property” means all patents, trademarks, service marks, logos, get-up, trade names, internet domain names, rights in designs, blue prints, programs and manuals, drawings, copyright (including rights in computer software), database rights, semi-conductor, topography rights, utility models, rights in know-how and other intellectual property rights, in each case whether registered or unregistered and including applications for registration, and all rights or forms of protection having equivalent or similar effect anywhere in the world;

“LOA” or “Letter of Award” means the letter of award referred to in Recital(D);

“Lead Member” shall have the meaning set forth in Recital (D);



“Lenders’ Representative” means the person duly authorized by the Senior Lenders to act for and on behalf of the Senior Lenders with regard to matters arising out of or in relation to this Agreement, and includes his successors, assigns and substitutes;

“Licensed Premises” shall have the meaning as set forth in Clause 10.2.2;

“MoRTH” means the Ministry of Road Transport and Highways or any substitute thereof dealing with highways;

“Maintenance Manual” shall have the meaning as set forth in Clause 17.3.1;

“Maintenance Program” shall have the meaning as set forth in Clause 17.4.1;

“Maintenance Requirements” shall have the meaning as set forth in Clause 17.2;

“Material Adverse Effect” means a material adverse effect of any act or event on the ability of either Party to perform any of its obligations under and in accordance with the provisions of this Agreement and which act or event causes a material financial burden or loss to either Party;

“Nominated Company” means a company selected by the Lenders’ Representative and proposed to the Authority for substituting the Concessionaire in accordance with the provisions of the Substitution Agreement;

“Non-Political Event” shall have the meaning as set forth in Clause 28.2;

“O&M” means the operation and maintenance of the Project and includes all matters connected with or incidental to such operation and maintenance, and provision of services and facilities, in accordance with the provisions of this Agreement;

“O&M Contract” means the operation and maintenance contract that may be entered into between the Concessionaire and the O&M Contractor for performance of all or any of the O&M obligations;

“O&M Contractor” means the person, if any, with whom the Concessionaire has entered into an O&M Contract for discharging O&M obligations for and on behalf of the Concessionaire;

“O&M Expenses” means expenses incurred by or on behalf of the Concessionaire or by the Authority, as the case may be, for all O&M including (a) cost of salaries and other compensation to employees, (b) cost of materials, supplies, utilities and other services, (c) premium for insurance, (d) all taxes, duties, cess and fees due and payable for O&M, (e) all repair, replacement, reconstruction, reinstatement, improvement and maintenance costs, (f) payments required to be made under the O&M Contract or any other contract in connection with or incidental to O&M, and (g) all other expenditure required to be incurred under Applicable Laws, Applicable Permits or this Agreement;

“O&M Inspection Report” shall have the meaning as set forth in Clause 19.2;

“O&M Payments” shall have the meaning as set forth in Clause 23.7.1;



“Operation Period” means the operation and maintenance period of 15 (fifteen) years commencing from COD and ending on the Transfer Date;

“Parties” means the parties to this Agreement collectively and “Party” shall mean any of the parties to this Agreement individually;

“Payment Milestone” shall have the meaning as set forth in Clause 23.4;

“Performance Guarantee” shall have the meaning as set forth in Clause 33.2.3;

“Performance Security” shall have the meaning as set forth in Clause 9.1.1;

“Physical Progress” shall mean the physical construction of the Project completed by the Concessionaire and shall be measured as per the assessment done by the Independent Engineer in accordance with Clause 23.4 of this Agreement.

“Political Event” shall have the meaning as set forth in Clause 28.4;

“Price Index” shall comprise:

- (a) 70% (seventy per cent) of WPI; and
- (b) 30% (thirty per cent) of CPI (IW),

Which constituents may be substituted by such alternative index or indices as the Parties may by mutual consent determine;

“Price Index Multiple” shall have the meaning set forth in 23.2.3;

“Project” means the construction, operation and maintenance of the Project in accordance with the provisions of this Agreement, and includes all works, services and equipment relating to or in respect of the Scope of the Project in Site comprising the existing road comprising NH-163 from km **Design Km 14.000/Existing Km 14.000**) to km **(Design Km 60.405/Existing Km 59.500)** and all Project Assets, and its subsequent development and augmentation in accordance with this Agreement ;

“Project Agreements” means this Agreement, the Financing Agreements, EPC Contract, O&M Contract, and any other material agreements or contracts that may be entered into by the Concessionaire with any person in connection with matters relating to, arising out of or incidental to the Project, but does not include the Escrow Agreement, Substitution Agreement, or any agreement for procurement of goods and services involving a consideration of up to Rs.25 crore (twenty five crore)⁸;

“Project Assets” means all physical and other assets relating to and forming part of the Site including (a) rights over the Site in the form of license, Right of Way or otherwise; (b) tangible assets such as civil works and equipment including foundations, embankments, pavements, road surface, interchanges, bridges, culverts, road over bridges, drainage works, traffic signals, sign boards, kilometer-stones, toll plaza(s), electrical systems, communication systems, rest areas, relief centers, maintenance depots and administrative offices; (c) Project Facilities situated on the Site; (d) all rights

⁸This may be fixed at the higher of: (a) 2% (two per cent) of Total Project Cost and (b) Rs. 25 (twenty five) crore.



of the Concessionaire under the Project Agreements; (e) financial assets, such as receivables, security deposits etc.; (f) insurance proceeds; and (g) Applicable Permits and authorizations relating to or in respect of the Project;

“Project Completion Schedule” means the progressive Project Milestones set forth in Schedule-G for completion of the Project on or before the Scheduled Completion Date;

“Project Facilities” means all the amenities and facilities situated on the Site, as described in Schedule-C;

“Project Highway” means the Site comprising the existing road comprising NH- 163 - from km **Design Km 14.000/Existing Km 14.000**) to km **(Design Km 60.405/Existing Km 59.500)** and all Project Assets, and its subsequent development and augmentation in accordance with this Agreement;

“Project Milestones” means the project milestones as set forth in Schedule-G;

“Provisional Certificate” shall have the meaning as set forth in Clause 14.3;

“Punch List” shall have the meaning ascribed to it in Clause 14.3.1 and, if applicable, shall only include any or all of the below:

- (i) plantation of avenue trees along the edge of the RoW and other landscaping works within RoW
- (ii) completion of work on Provision of Unlined Roadside Drains
- (iii) lining of roadside drains in identified stretches
- (iv) construction of rest areas, as approved
- (v) completion of Fencing Works of RoW
- (vi) turfing on embankment slopes in identified sections
- (vii) pointing to Stone Masonry works in identified Cross Drainage Structures
- (viii) stone Pitching at identified locations

“RBI” means the Reserve Bank of India, as constituted and existing under the Reserve Bank of India Act, 1934, including any statutory modification or replacement thereof, and its successors;

“Re.”, “Rs .” or “Rupees” or “Indian Rupees” means the lawful currency of the Republic of India;

“Reference Exchange Rate” means, in respect of any one currency that is to be converted into another currency in accordance with the provisions of this Agreement, the exchange rate as of 12.00 (twelve) noon on the relevant date quoted in Delhi by the State Bank of India, and in the absence of such rate, the average of similar rates quoted in Delhi by the Bank of India and the Bank of Baroda;

“Reference Index Date” means, in respect of the specified date or month, as the case may be, that last day of the preceding month with reference to which the Price Index or any constituent thereof is revised and in the event such revision has not been notified,



the last such Price Index or any constituent thereof shall be adopted provisionally and used until the Price Index or such constituent thereof is revised and notified;

“Request for Proposals” or **“RFP”** shall have the meaning as set forth in Recital (B);

“Right of Way” means the constructive possession of the Site, together with all way leaves, easements, unrestricted access and other rights of way, howsoever described, necessary for construction, operation and maintenance of the Project in accordance with this Agreement;

“Safety Consultant” shall have the meaning as set forth in Clause 18.1.2;

“Safety Requirements” shall have the meaning as set forth in Clause 18.1.1;

“Scheduled Completion Date” shall have the meaning as set forth in Clause 12.3.1;

“Scope of the Project” shall have the meaning as set forth in Clause 2.1;

“Senior Lenders” means the financial institutions, banks, multilateral lending agencies, trusts, funds and agents or trustees of debenture holders, including their successors and assignees, who have agreed to guarantee or provide finance to the Concessionaire under any of the Financing Agreements for meeting all or any part of the Total Project Cost and who hold pari passu charge on the assets, rights, title and interests of the Concessionaire;

“Site” shall have the meaning as set forth in Clause 10.1;

“Specifications and Standards” means the specifications and standards relating to the quality, quantity, capacity and other requirements for the Project, as set forth in Schedule-D, and any modifications thereof, or additions thereto, as included in the design and engineering for the Project submitted by the Concessionaire to, and expressly approved by, the Authority;

“State” means the State of Telangana and **“State Government”** means the government of that State;

“Statutory Auditors” means a reputable firm of chartered accountants acting as the statutory auditors of the Concessionaire under the provisions of the Companies Act, 2013, including any re-enactment or amendment thereof, for the time being in force, and appointed in accordance with Clause 27.2.1;

“Subordinated Debt” means the aggregate of the following sums expressed in Indian Rupees or in the currency of debt, as the case may be, outstanding as on the Transfer Date:

- (a) the principal amount of debt provided by lenders or the Concessionaire’s shareholders for meeting the Total Project Cost and subordinated to the financial assistance provided by the Senior Lenders; and
- (b) all accrued interest on the debt referred to in Sub-clause (a) above but restricted to the lesser of actual interest rate and a rate equal to 5% (five per cent) above the Bank Rate in case of loans expressed in Indian Rupees and lesser of the



actual interest rate and 6 (six) month LIBOR (London Inter-Bank Offer Rate) plus 2% (two per cent) in case of loans expressed in foreign currency, but does not include any interest that had fallen due 1 (one) year prior to the Transfer Date;

provided that if all or any part of the Subordinated Debt is convertible into Equity at the option of the lenders and/or the Concessionaire's shareholders, it shall for the purposes of this Agreement be deemed to be Subordinated Debt even after such conversion and the principal thereof shall be dealt with as if such conversion had not been undertaken;

"Substitution Agreement" shall have the meaning as set forth in Clause 34.3.1;

"Suspension" shall have the meaning as set forth in Clause 30.1;

"Taxes" means any Indian taxes including GST, excise duties, customs duties, value added tax, sales tax, local taxes, cess and any impost or surcharge of like nature (whether Central, State or local) on the goods, materials, equipment and services incorporated in and forming part of the Project charged, levied or imposed by any Government Instrumentality, but excluding any interest, penalties and other sums in relation thereto imposed on any account whatsoever. For the avoidance of doubt, Taxes shall not include taxes on corporate income;

"Termination" means the expiry or termination of this Agreement and the Concession hereunder;

"Termination Notice" means the communication issued in accordance with this Agreement by one Party to the other Party terminating this Agreement;

"Termination Payment" means the amount payable by the Authority to the Concessionaire, under and in accordance with the provisions of this Agreement, upon Termination;

"Tests" means the tests set forth in Schedule-I to determine the completion of the Project in accordance with the provisions of this Agreement;

"Total Project Cost" means 60 % (sixty percent) of the Bid Project Cost specified in Clause 23.1;

provided that in the event WPI increases, on an average, by more than 3% (three per cent) per annum for the period between the Bid Date and COD, the amount hereinbefore specified shall be increased such that the effect of increase in WPI, in excess of such 3% (three per cent), is reflected in the Total Project Cost;

provided further that in the event of Termination, the Total Project Cost shall be deemed to be modified to the extent of variation in WPI or Reference Exchange Rate occurring in respect of Debt Due, as the case may be, in accordance with the provisions of this Agreement;

Provided also that the Total Project Cost shall not exceed 60% of the actual capital expenditure on the Project and capitalized in the books of accounts of the Concessionaire as certified by the Statutory Auditor;



“Transfer Date” means the date on which this Agreement and the Concession hereunder expires pursuant to the provisions of this Agreement or is terminated by a Termination Notice;

“User” means a person who uses or intends to use the Project or any part thereof in accordance with the provisions of this Agreement and Applicable Laws;

“Vesting Certificate” shall have the meaning as set forth in Clause 32.4; and

“WPI” means the Wholesale Price Index for all commodities as published by the Ministry of Industry, GOI and shall include any index which substitutes the WPI, and any reference to WPI shall, unless the context otherwise requires, be construed as a reference to the latest monthly WPI published no later than 30 (thirty) days prior to the date of consideration hereunder.



NOW, THEREFORE, in consideration of the foregoing and the respective covenants and agreements set forth in this Concession Agreement, the receipt and sufficiency of which is hereby acknowledged, and intending to be legally bound hereby, the Parties agree as follows:

IN WITNESS WHEREOF THE PARTIES HAVE EXECUTED AND DELIVERED THIS AGREEMENT AS OF THE DAY, MONTH AND YEAR FIRST ABOVE WRITTEN.

SIGNED, SEALED AND DELIVERED For and on behalf of **THE AUTHORITY** by:

SIGNED, SEALED AND DELIVERED For and on behalf of **THE CONCESSIONAIRE** by:



(Ajay Singh Bargoti)
General Manager (T)
(Telangana Division)
National Highways Authority of India (NHAI)
G-5&6, Sector-10, Dwarka,
New Delhi-110 075



(K. Raja Ravindra Babu)
MEIL Appa Junction Manneguda Roadways Pvt. Ltd,
Unit 22, Technocrat Industrial Estate, Bala Nagar
Hyderabad, Rangareddi, Telangana,
India - 500 033

THE COMMON SEAL OF CONCESSIONAIRE has been affixed pursuant to the resolution passed by the Board of Directors of the Concessionaire at its meeting held on the 22.04.2022 hereunto affixed in the presence of Shri Ch V Madhusudana Rao, Director who has signed these Presents in token thereof:



In the presence of **Witnesses**:

1. Signature: 
Name: Vinay Kumar Dani
Address: CAN 01

2. Signature: 
Name: (N.K. Jais)
Address: DAM 01/MEIL/110

In the presence of **Witnesses**:

1. Signature: 
Name: K. Raja Ravindra Babu
Address: S-2; TIE; Balanagar; Hyderabad.

2. Signature: Kuldeep
Name: Kuldeep Kumar
Address: Inelirapuram, Ghaziabad

अतः अब, पूर्वोक्त तथा संबंधित प्रसंविदाओं और इस करार में उल्लिखित सहमतियों को ध्यान में रखते हुए, जिसकी पर्याप्तता और उपयुक्तता को एतद्वारा स्वीकार किया जाता है और एतद्वारा कानूनी तौर पर बाध्यकारी हैं, दोनों पक्ष निम्नलिखित के लिए सहमत हो गए हैं:

इसके साक्ष्यस्वरूप दोनों पक्षों ने इस करार को पहले ऊपर लिखी तिथि, माह और वर्ष को निष्पादित किया और सौंप दिया।

हस्ताक्षर किए मुहरबंद किया और सौंप दिया

कृते भारतीय राष्ट्रीय राजमार्ग प्राधिकरण
द्वारा :



(अजय सिंह बरगोटी)

महाप्रबंधक (तकनीकी)

(तेलंगाना प्रभाग)

भारतीय राष्ट्रीय राजमार्ग प्राधिकरण(एनएचएआई)

जी-5 और 6, सेक्टर-10 द्वारका,

नई दिल्ली-110075

हस्ताक्षर किए मुहरबंद किया और सौंप दिया

कृते रियायतग्राही
द्वारा :



(के.राजा रविंद्रा बाबु)

एमईआईएल अप्पा जक्शन मन्नेगुडा रोडवेज प्राइवेट लिमिटेड,

यूनिट 22, टेक्नोक्रेट इंडस्ट्रियल एस्टेट, बाला नगर हैदराबाद,

रंगारेड्डी, तेलंगाना, भारत - 500 033

रियायतग्राही के निदेशक मण्डल द्वारा 22.04.2022 को हुई अपनी बैठक में पारित संकल्प के अनुसरण में श्री सिधेव वि मूथसदन राव, निदेशक की उपस्थिति में रियायतग्राही की सामान्य मुहर लगाई गई और उन्होंने इसके परिणामस्वरूप इस विलेख पर अपने हस्ताक्षर किए।

साक्षी :

1. हस्ताक्षर

नाम :

पता :

विश्व सुधा बंसा
मु. महा उद्योग

2. हस्ताक्षर

नाम :

पता :

UNDE JAIN
DUMCE INHABITANCE

साक्षी :

1. हस्ताक्षर

नाम :

पता :

K. Raja Ravindra Babu
S-2, TIE Balanagar, Hyderabad

2. हस्ताक्षर

नाम :

पता :

Kuldeep
Kuldeep Kumar
Indrapuram, Ghaziabad

Schedules



Four laning of NH-163 from Hyderabad (ORR Appa Junction) (Design Km 14.000/Existing Km 14.000) to Manneguda (Design Km 60.405/Existing Km 59.500) (Design Length = 46.405 Km) in the State of Telangana under NH(O) on Hybrid Annuity Mode Page 149



Four laning of NH-163 from Hyderabad (ORR Appa Junction) (Design Km 14.000/Existing Km 14.000) to Manneguda (Design Km 60.405/Existing Km 59.500) (Design Length = 46.405 Km) in the State of Telangana under Bharatmala Pariyojna on Hybrid Annuity Mode

SCHEDULE- A

(See Clauses 2.1 and 8.1)

SITE OF THE PROJECT

1. The Site

- 1.1 The site of project highway shall include land, buildings, structures and road works as described in Annex-I of this Schedule-A.
- 1.2 The dates of handing over the Right of Way to the Concessionaire are specified in Annex-II of this Schedule-A.
- 1.3 An inventory of the Site including the land, buildings, structures, road works, trees and any other immovable property on, or attached to, the Site shall be prepared jointly by the Authority Representative and the Concessionaire, and such inventory shall form part of the memorandum referred to in Clause 10.3.1 of this Agreement.
- 1.4 The alignment plans of the Project Highway are specified in Annex-III of Schedule-A. The proposed levels (FRL) as indicated in the alignment plan shall be minimum requirement and treated as an approximate assessment. The Concessionaire shall design the Road Profile as per the finalized Detailed Project Report (DPR) including plan & profile of the project highway based on site/design requirement, prepared by the Concessionaire.
- 1.5 The status of the environment clearances obtained or awaited is given in Annex IV.



Four laning of NH-163 from Hyderabad (ORR Appa Junction) (Design Km 14.000/Existing Km 14.000) to Manneguda (Design Km 60.405/Existing Km 59.500) (Design Length = 46.405 Km) in the State of Telangana under Bharatmala Pariyojna on Hybrid Annuity Mode

Annex – I
(Schedule-A)

Site

- 1. The Site:** The site of two/four lane project highway comprises of section of National Highway 163 of Hyderabad (ORR-Appa Junction) (Design Ch: 14+000/Existing Km. 14.000) to Manneguda (Design Ch: 60+405/Existing Km.59.500) in the State of Telangana. The land, carriageway and structures comprising the Site are described below.

Sl. No	Ex. Chainage (Km)	Design Chainage (Km)	Remarks
1	14	14+000	Start of Project
2	15	15+000	Stone is missing
3	16	16+000	
4	17	17+030	
5	18	18+010	
6	19	19+005	
	19.49	19+500	Realignment
7	20	-	
	20.3	20+225	
8	21	20+940	
9	22	-	Moinabad Bypass of length 4.35 km
10	23 (Stone is missing)	-	
11	24 (Stone is missing)	-	
12	25	-	
13	26	-	
14	26.12	26+300	
15	27	27+140	
16	28	28+150	
17	29	29+150	
18	30	30+170	
19	31	31+170	
20	32	32+165	
21	33	33+120	
22	34	34+150	
23	35	35+130	
24	36	36+120	
25	37 (Stone is missing)	-	Chevella Bypass of length 6.36 km
26	38 (Stone is missing)	-	
27	38.65	38+700	
28	39	-	
29	40	-	
30	41 (Stone is missing)		
31	42 (Stone is missing)		
32	43 (Stone is missing)		



Four laning of NH-163 from Hyderabad (ORR Appa Junction) (Design Km 14.000/Existing Km 14.000) to Manneguda (Design Km 60.405/Existing Km 59.500) (Design Length = 46.405 Km) in the State of Telangana under Bharatmala Pariyojna on Hybrid Annuity Mode

Sl. No	Ex. Chainage (Km)	Design Chainage (Km)	Remarks
33	44	-	
34	44.12	45+060	
35	45	45+940	
36	46	46+920	
37	47	47+920	
38	48	48+920	
39	49	49+895	
40	50	50+910	
41	51	51+910	
42	52	52+920	
43	53	53+870	
44	54	54+875	
45	55	55+880	
46	56	56+865	
47	57	57+860	
48	58	58+860	
49	59	59+855	
50	59.500	60+405	Project end

2. **Land:** The Site of the Project Highway comprises the land as described below:

Sl. No.	Existing Chainage		Average Existing ROW (m)
	From (km)	To (km)	
1	14	15	22
2	15	16	18.5
3	16	17	18.5
4	17	18	28
5	18	19	30
6	19	20	30
7	20	21	30
8	21	22	29
9	22	23	26
10	23	24	20
11	24	25	20
12	25	26	24
13	26	27	24
14	27	28	22
15	28	29	20
16	29	30	24
17	30	31	21.5
18	31	32	27
19	32	33	30

Four laning of NH-163 from Hyderabad (ORR Appa Junction) (Design Km 14.000/Existing Km 14.000) to Manneguda (Design Km 60.405/Existing Km 59.500) (Design Length = 46.405 Km) in the State of Telangana under Bharatmala Pariyojna on Hybrid Annuity Mode

Sl. No.	Existing Chainage		Average Existing ROW (m)
	From (km)	To (km)	
20	33	34	30
21	34	35	30
22	35	36	30
23	36	37	30
24	37	38	30
25	38	39	27
26	39	40	22.6
27	40	41	25
28	41	42	16
29	42	43	22
30	43	44	25
31	44	45	24
32	45	46	25
33	46	47	30
34	47	48	28.5
35	48	49	30
36	49	50	30
37	50	51	30
38	51	52	22
39	52	53	30
40	53	54	30
41	54	55	30
42	55	56	30
43	56	57	24
44	57	58	30
45	58	59	30
46	59	60	30

Note: The substantial Land for construction of the project & scope of work has already been acquired as per the requirement and shall be handed over to the Concessionaire before commencement of construction activities. However, it may have some encroachments which shall be removed jointly by the parties with the help of State Authorities. So Authority shall only be responsible to provide the site/land free from legal encumbrance and w.r.t. illegal encroachments, Authority will provide help to the Concessionaire for its removal.

3. **Carriageway:** The present carriageway of the Project Highway is Two/Four Lane. The type of the existing pavement is Flexible.

Sl. No.	Existing Chainage		Total Length in km	Lane Configuration	Remarks
	From (km)	To (km)			
1	14.00	25.47	11.47	4 Lane	
2	25.47	27.80	2.33	2 lane	
3	27.80	28.50	0.70	Undivided Dual Intermediate lane	10.1 m curve @ Curve location
4	28.50	29.10	0.60	2 lane	

Four laning of NH-163 from Hyderabad (ORR Appa Junction) (Design Km 14.000/Existing Km 14.000) to Manneguda (Design Km 60.405/Existing Km 59.500) (Design Length = 46.405 Km) in the State of Telangana under Bharatmala Pariyojna on Hybrid Annuity Mode

Sl. No.	Existing Chainage		Total Length in km	Lane Configuration	Remarks
	From (km)	To (km)			
5	29.10	29.50	0.40		16 m curve @ Curve location
6	29.50	31.90	2.40	2 lane	
7	31.90	33.35	1.45	Undivided Dual Intermediate lane	11m curve @ Curve location
8	33.35	36.15	2.80	2 lane	
9	36.15	36.60	0.45	Undivided Dual Intermediate lane	10.5 curve @ Curve location
10	36.60	37.60	1.00	2 lane	
11	37.60	37.90	0.30	4 lane	15m (7.2+0.5+7.2)
12	37.90	40.10	2.20	2 lane	
13	40.10	43.10	3.00	4 lane	Divided (Chevella)
14	43.10	45.50	2.40	2 lane	
15	45.50	45.80	0.30	Undivided Dual Intermediate lane	11m Curve @ Curve location
16	45.80	54.55	8.75	2 lane	
17	54.55	54.85	0.30	Undivided Dual Intermediate lane	11m @ Curve location
18	54.85	59.54	4.69	2 lane	

4. Service Roads / Slip roads: The details of the service road/slip roads are in table below:

S. No	Existing Chainage (Km)		Road width	Side	Remarks
	From	To			
-NIL-					

5. Bypasses: The details of the existing bypasses are as in the table below:

Sl. No	Name of Bypass (town)	Existing Chainage (Km)		Length in (Km)	Carriageway	
		From – To			Width (m)	Type
-NIL-						

6. Major Bridges: The Site includes the following Major Bridges:

Sl. No.	Existing Chainage (km)	Type of Structure			No of Spans with Span Length (m)	Width (m)
		Foundation	Sub Structure	Super Structure		
-NIL-						

Causeway

The Site includes the following causeways.

		Type of Structure		
-NIL-				



Four laning of NH-163 from Hyderabad (ORR Appa Junction) (Design Km 14.000/Existing Km 14.000) to Manneghuda (Design Km 60.405/Existing Km 59.500) (Design Length = 46.405 Km) in the State of Telangana under Bharatmala Pariyojna on Hybrid Annuity Mode

Sl. No.	Existing Chainage (km)	Foundation	Sub Structure	Super Structure	No. of Spans with span length (m)	Width (m)
-NIL-						

7. Road over-bridges (ROB)/Road under-bridges (RUB):

The Site includes the following ROB (road over railway line)/RUB (road under railway line):

Sl. No.	Existing Chainage (km)	Type of Structure		No. of Spans with span length (m)	Width (m)
		Foundation	Superstructure		
-NIL-					

8. Grade separators:

The Site includes the following grade separators.

Sl. No.	Existing Chainage (km)	Type of Structure	No. of Spans with Span length(m)	Width (m)
-NIL-				

9. Vehicle Underpass:

The Site includes the following underpass:

Sl. No.	Existing Chainage (km)	Type of Structure	No. of Spans with span length (m)	Width (m)
-NIL-				

10. Vehicle Overpass:

The Site includes the following Overpass:

Sl. No.	Existing Chainage (km)	Type of Structure			No of Spans with Span Length (m)	Width (m)
		Foundation	Sub Structure	Super Structure		
-NIL-						

11. Cattle/Pedestrian Underpass:

The Site includes the following Cattle/Pedestrian underpass:

Sl. No.	Existing Chainage (km)	Type of Structure	No. of Spans with span length (m)	Width (m)
-NIL-				

12. Minor Bridges:

The Site includes the following Minor bridges:

Sl. No.	Existing Chainage (km)	Type of Crossing	Existing Structure Details			
			Span Arrangement (m)	Super Structure	Carriageway Width (m)	Deck Width (m)
1	23.400	MNB	2 x 3.0	RCC Solid Slab	9.00	22.20



Four laning of NH-163 from Hyderabad (ORR Appa Junction) (Design Km 14.000/Existing Km 14.000) to Manne-guda (Design Km 60.405/Existing Km 59.500) (Design Length = 46.405 Km) in the State of Telangana under Bharatmala Pariyojna on Hybrid Annuity Mode

13. Railway level crossings: The Site includes the following railway level crossings:

S. No.	Location(km)	Remarks
-NIL-		

14. Culverts:

The Site has the following culverts:

14.1 Pipe Culverts

Sl. No.	Existing Chainage (km)	Span/ Opening with Span Length (m)	Width(m)	Clear Carriageway (m)
1	17.500	1 x 0.60	20.40	14.00
2	19.300	2 x 0.60	22.50	15.50
3	21.300	1 x 0.60	21.80	15.00
4	22.300	1 x 1.20	22.70	13.60
5	25.210	1 x 0.90	21.00	14.00
6	25.900	1 x 0.75	12.00	7.00
7	27.890	2 x 0.90	22.10	15.50
8	31.500	1 x 0.90	12.80	7.00
9	38.300	1 x 0.45	12.70	7.00
10	41.190	1 x 1.20	15.00	7.00
11	41.200	1 x 0.90	27.50	13.0
12	41.210	1 x 0.75	15.00	7.00
13	46.700	2 x 0.45	12.40	6.50
14	47.390	2 x 0.45	12.60	6.20
15	50.358	2 x 0.45	12.00	6.50
16	53.050	2 x 0.45	12.00	6.50
17	56.850	2 x 0.90	12.50	6.70
18	57.250	1 x 0.60	12.00	6.50
19	59.300	2 x 1.00	13.200	7.00

14.2 Slab Culverts

Sl. No.	Existing Chainage (Km)	Span/ Opening with Span Length (m)	Width (m)	Clear Carriageway (m)
1	19.800	1 x 2.0	22.80	15.80
2	20.100	1 x 5.0	16.50	15.10
3	28.990	2 x 1.0	11.80	6.80
4	29.600	1 x 3.0	11.00	6.00
5	36.100	1 x 2.0	11.70	7.00
6	39.900	1 x 4.5	12.00	7.00
7	48.700	1 x 4.0	12.00	6.50
8	48.900	1 x 1.0	12.00	6.50
9	55.550	1 x 1.5	12.00	6.50
10	56.440	1 x 2.4	12.00	6.50
11	58.990	1 x 2.3	12.00	6.50



Four laning of NH-163 from Hyderabad (ORR Appa Junction) (Design Km 14.000/Existing Km 14.000) to Manne-guda (Design Km 60.405/Existing Km 59.500) (Design Length = 46.405 Km) in the State of Telangana under Bharatmala Pariyojna on Hybrid Annuity Mode

15. Bus bays:

The details of bus bays on the Site are as follows:

Sr. No.	Chainage (Km)	Length (m)	Left Hand Side	Right Hand side
-Nil-				

16. Truck Lay byes:

The details of truck lay byes are as follows:

Sr. No.	Chainage (Km)	Length (m)	Left Hand Side	Right Hand side
-Nil-				

17. Major junctions:

The details of major junctions are as follows:

Sl. No.	Existing chainage (Km)	At Grade	Leads to			
			NH	SH	MDR	Others
-						

18. Minor junctions:

The details of the minor junctions are as follows:

Sl. No.	Existing Km	Type of Junction	Leads to	
			LHS	RHS
1	14.212	T	-	Narsing to appa service road
2	14.580	T	-	Appa Service road
3	15.200	T	Aziz nagar	-
4	17.275	Y	Aziz nagar	Gandhipet
5	18.525	Y	Bakar ram	-
6	19.970	Y	Enkepally	-
7	20.215	Y	-	Himayathnagar
8	22.000	Y	Murthuzaguda	-
9	24.675	T	Moinabad village	Moinabad village
10	24.975	X	Sriram nagar	Peddamangalaram
11	27.145	Y	Kanaka mamidi road	-
12	27.890	Y	Kanaka mamidi road	-
13	27.500	+	Kanaka mamidi road	Peddamangalram
14	28.850	T	-	Village
15	30.670	Y	Anjanpally	-
16	31.225	T	-	Appa reddy guda
17	32.040	T	Tollkatta	-
18	33.275	Y	-	Mudimyal
19	36.500	T	Palgutta	-
20	37.760	T	-	Malkapur
21	39.185	T	-	Kesaram



Four laning of NH-163 from Hyderabad (ORR Appa Junction) (Design Km 14.000/Existing Km 14.000) to Manneguda (Design Km 60.405/Existing Km 59.500) (Design Length = 46.405 Km) in the State of Telangana under Bharatmala Pariyojna on Hybrid Annuity Mode

Sl. No.	Existing Km	Type of Junction	Leads to	
			LHS	RHS
22	40.775	T	Allawada	
23	41.212	T	Chevalla village cross road	-
24	41.245	T	-	Chevalla village cross road
25	41.557	T	Chevalla village cross road	-
26	41.664	T	Chevalla village cross road	-
27	41.910	T	-	Malkapur
28	41.925	T	Chevalla village cross road	-
29	42.060	+	Chavalla village	Chavalla village
30	42.140	T	-	Dharma sagar
31	42.275	T	-	Chevalla village cross road
32	42.375	T	-	Chevalla village cross road
33	43.458	T	-	Ibrahampalle
34	43.750	T	-	Ibrahampalle
35	45.665	T	-	Sjhn college of engineering
36	45.770	Y	Dameriguda	-
37	49.135	X	Bastepur	Mirjaguda
38	51.385	Y	Khanapur	-
39	51.560	T	Cross road	-
40	52.400	Y	Khanapur	-
41	52.455	T	-	Kisthapur
42	54.900	+	Angadichitampally	Antharam
43	57.095	T	Kandlapally	-
44	58.945	T	-	Gangupalle

19. Total number of structures on the Site

Total numbers of structures on the site are noted below:

S. No.	Description	No.
1	Total number of Major bridges	Nil
2	Total number of ROBs/RUBs	Nil
3	Total number of Minor Bridges	01
4	Total number of Slab Culverts	11
5	Total number of Pipe Culverts	19
6	Total number of Arch Culverts	Nil
7	Total number of Grade Separators	Nil
8	Total number of Vehicular and Non Vehicular Underpasses	Nil
9	Total number of Vehicular Overpass	Nil
10	Total number of Causeways	Nil

Four laning of NH-163 from Hyderabad (ORR Appa Junction) (Design Km 14.000/Existing Km 14.000) to Mannequda (Design Km 60.405/Existing Km 59.500) (Design Length = 46.405 Km) in the State of Telangana under Bharatmala Pariyojna on Hybrid Annuity Mode

20. Rest Area (Wayside Amenities)

The details of wayside amenities are as follows:

S. No.	Location(km)	Remarks
-Nil-		

21. Toll plaza

The details of Toll plaza are as follows:

S. No.	Location(km)	Remarks
-Nil-		

22. Bus Bays & Truck Lay byes

The details of bus bays and Truck lay byes are as follows:

- (a) No. of Bus bays - Nil
- (b) Truck lay bye on LHS – Nil
- (c) Truck lay bye on RHS – Nil

23. Forest Locations

Existing Chainage (km)		Name of the Forest / Protected Area	Side	Distance from Existing Center Line (m)	Length of Forest / Protected Area along the road (m)
From	To				
Shamshabad Division, Chilkur Range					
32.84	33.13	Mudimiyal Reserve Forest	RHS	20	290
33.13	33.26	Mudimiyal Reserve Forest	RHS	Varying (from 18 m to 80 m)	130
33.42	37.76	Mudimiyal Reserve Forest	Both	10	4340
Vikarabad Division, Vikarabad Range					
56.87	57.00	Khandlapally Reserve Forest	LHS	11	130
57.00	58.10	Khandlapally Reserve Forest	Both Sides	6	1100
58.10	58.84	Khandlapally Reserve Forest	LHS	11	740
Total length of forest along the proposed road					6730

Four laning of NH-163 from Hyderabad (ORR Appa Junction) (Design Km 14.000/Existing Km 14.000) to Manneguda (Design Km 60.405/Existing Km 59.500) (Design Length = 46.405 Km) in the State of Telangana under Bharatmala Pariyojna on Hybrid Annuity Mode

25. Utilities

(i) **Electrical Utilities** : The site includes the following electrical utilities.

(a) Existing EHT Lines (132 KV/ 220 KV/ 400 KV) on Lattice Type Towers

Sl. No.	Chainage No.	Height of existing line from existing road land	Height expected from FRL	Existing Line (Voltage)	Remarks
1	45+100	12.0 M	10.50 M	220 KV (D/C)	Road centre to existing Tower = 200 meters (LHS) Road Centre to existing Tower = 150 meter (RHS)
2	49+500	18.5 M	16.00 M	220 KV (D/C)	Road Centre to Tower – 100 M (RHS) Road Centre to Tower – 100 M (LHS)
3	50+700	20.0 M	19.00 M	400 KV (D/C)	Road Centre to Tower –80 M (LHS) Road Centre to Tower –80 M (LHS)
4	52+600	16.0 M	15.00 M	132 KV (D/C)	Road Centre to Tower –100 M (LHS) Road Centre to Tower –100 M (RHS)
5	55+100	14.0 M	12.50 M	132 KV (D/C)	Road Centre to Tower –100 M (LHS) Road Centre to Tower – 60 M (RHS)
6	28+300	14.0 M	9.00 M	132 KV (D/C)	Road Centre to Tower –160 M (LHS) Road Centre to Tower –100 M (RHS)

Notes:

1. Out of 6 nos. EHT lines presently crossing the road, shifting/ realignment of 1no. 220 KV D/C at Sl. No. 1 and 1 no. 132 KV D/C line at Sl. No. 6 above has been considered. The cost estimation as per utility proposal is with interposing two nos. angle lattice type towers, one no. on either side of road, for raising bottom most conductor to achieve safe ground clearance from road revised Formation Level (FRL).
2. Remaining 4 nos. EHT lines, through presently crossing the redefined ROW, are not a cause of hindrance to road implementation project and thus are not required to be shifted/ realigned.
3. Cost of shifting/ realignment of 1 no. existing 220 KV D/C Line and 1 no. 132 KV D/C Line has been considered in cost estimates.

(b) 11 KV Overhead line and LT Line (Composite to 11 KV Line)

Sl. No.	Chainage From – To	Line Length (in mtrs.)	Height & type of existing pole	Size of existing ACSR	Nos of existing SP/DP and TP/FP structures	Whether on LHS or RHS of Road
1.	18+600 to 19+000	400	9.1 Mtr. PCC Pole	AAAC 50 sq. mm. plus weasel	SP-9	LHS

Four laning of NH-163 from Hyderabad (ORR Appa Junction) (Design Km 14.000/Existing Km 14.000) to Manneghuda (Design Km 60.405/Existing Km 59.500) (Design Length = 46.405 Km) in the State of Telangana under Bharatmala Pariyojna on Hybrid Annuity Mode

2.	18+500 to 18+800	300	9.1 Mtr. PCC Pole	AAAC 50 sq. mm. plus ABC	SP-9	RHS
3.	19+400 to 19+600	200	9.1 Mtr. PCC Pole	AAAC 50 sq.mm plus ABC	SP-7	LHS
4.	20+100 to 20+350	250	9.1 Mtr. PCC Pole	AAAC 50 sq.mm plus ABC	SP-7	LHS
5.	21+800 to 22+000	200	9.1 Mtr. PCC Pole	AAAC 50 sq.mm plus ABC	SP-5	LHS
6.	25+100 to 25+250	150	9.1 Mtr. PCC Pole	AAAC 50 sq.mm plus weasel	SP-5	LHS
7.	45+300 to 45+500	200	9.1 Mtr. PCC Pole	AAAC 50 sq.mm plus weasel	SP-7	LHS
8.	52+800 to 53+200	400	9.1 Mtr. PCC Pole	AAAC 50 sq.mm plus weasel	SP-8	LHS

Total length of LT O/H Line as composite to 11 KV O/H line on 9.1 M high PCC Poles obstructing ROW = 2.10 km.

(c) 11 KV Overhead Line

Sl. No.	Chainage From – To	Line Length (in mtrs.)	Height & type of existing pole	Size of existing ACSR	Nos of existing SP/DP and TP/FP structures	Whether on LHS or RHS of Road
1	19+000 to 19+600	600 mtr.	9.1 M PCC Pole	AAAC 50 sq. mm	SP-16	LHS
2	18+800 to 19+400	600 mtr.	9.1 M PCC Pole	AAAC 50 sq.mm	SP-17	RHS
3	20+350 to 22+000	1650 mtr.	9.1 M PCC Pole	AAAC 50 sq.mm	SP-35	LHS
4	21+600 to 21+800	200 mtr.	9.1 M PCC Pole	AAAC 50 sq.mm	SP-3	RHS
5	22+000 to 22+150	150 mtr.	9.1 M PCC Pole	AAAC 50 sq.mm	SP-4	RHS
6	Bypass	100 mtr.	9.1 M PCC Pole	AAAC 50 sq.mm	SP-2	RHS
7	27+400 to 28+300	900 mtr.	9.1 M PCC Pole	AAAC 50 sq.mm	SP-18	LHS

Four laning of NH-163 from Hyderabad (ORR Appa Junction) (Design Km 14.000/Existing Km 14.000) to Manne-guda (Design Km 60.405/Existing Km 59.500) (Design Length = 46.405 Km) in the State of Telangana under Bharatmala Pariyojna on Hybrid Annuity Mode

8	29+000 to 29+300	300 mtr.	9.1 M PCC Pole	AAAC 50 sq.mm	SP-10	RHS
9	29+300 to 32+550	2850 mtr.	9.1 M PCC Pole	AAAC 50 sq.mm	SP-65	LHS
10	30+800 to 31+200	400 mtr.	9.1 M PCC Pole	AAAC 50 sq.mm	SP-9	RHS
11	32+100 to 32+350	250 mtr.	9.1 M PCC Pole	AAAC 50 sq.mm	SP-6	RHS
12	38+400 to 38+900	500 mtr.	9.1 M PCC Pole	AAAC 50 sq.mm	SP-8	LHS
13	32+500 to 32+550	50 mtr.	9.1 M PCC Pole	AAAC 50 sq.mm	SP-1	RHS
14	33+400 to 33+500	100 mtr.	9.1 M PCC Pole	AAAC 50 sq.mm	SP-2	RHS
15	38+770 to 38+990	130 mtr.	9.1 M PCC Pole	AAAC 50 sq.mm	SP-2	RHS
16	45+100 to 45+300	200 mtr.	9.1 M PCC Pole	AAAC 50 sq.mm	SP-7	LHS
17	45+100 to 45+200	100 mtr.	9.1 M PCC Pole	AAAC 50 sq.mm	SP-3	RHS
18	45+500 to 45+800	300 mtr.	9.1 M PCC Pole	AAAC 50 sq.mm	SP-9	LHS
19	50+400 to 51+650	1250 mtr.	9.1 M PCC Pole	AAAC 50 sq.mm	SP-22	LHS
20	45+500 to 50+400	4900 mtr.	9.1 M PCC Pole	AAAC 50 sq.mm	SP-66	RHS
21	52+400 to 52+600	200 mtr.	9.1 M PCC Pole	AAAC 50 sq.mm	SP-3	LHS
22	53+200 to 53+700	500 mtr.	9.1 M PCC Pole	AAAC 50 sq.mm	SP-6	LHS
23	54+100 to 54+200	200 mtr.	9.1 M PCC Pole	AAAC 50 sq.mm	SP-4	LHS
24	53+350 to 59+450	6100 mtr.	9.1 M PCC Pole	AAAC 50 sq.mm	SP-78	LHS
25	56+650 to 56+950	300 mtr.	9.1 M PCC Pole	AAAC 50 sq.mm	SP-8	RHS
26	59+450 to 60+350	900 mtr.	9.1 M PCC Pole	AAAC 50 sq.mm	SP-21	RHS
27	59+400 to 59+900	500 mtr.	9.1 M PCC Pole	AAAC 50 sq.mm	SP-10	RHS
		24.230 km.			436 nos.	
Total Length of 11 KV Overhead Lines on 9.1 Mtr. PCC poles infringing ROW = 24.230 km.						

(d) LT (440 V) Overhead lines



151



Four laning of NH-163 from Hyderabad (ORR Appa Junction) (Design Km 14.000/Existing Km 14.000) to Manneguda (Design Km 60.405/Existing Km 59.500) (Design Length = 46.405 Km) in the State of Telangana under Bharatmala Pariyojna on Hybrid Annuity Mode

Sl. No.	Chainage From – To	Line Length (in mtrs.)	Height & type of existing pole	Size of existing ACSR	Whether on LHS or RHS of Road
1	18+600 to 18+800	200	9.1 Mtr. (280 kg.) PCC Pole	Weasel Conductor	LHS
2	19+450 to 19+500	50	9.1 Mtr. (280 kg.) PCC Pole	Weasel Conductor	RHS
3	32+950 to 33+400	50	9.1 Mtr. (280 kg.) PCC Pole	Weasel Conductor	RHS
4	52+150 to 52+400	450	9.1 Mtr. (280 kg.) PCC Pole	Weasel Conductor	LHS
5	55+250 to 55+350	250	9.1 Mtr. (280 kg.) PCC Pole	Weasel Conductor	LHS
6	55+750 to 55+850	100	9.1 Mtr. (280 kg.) PCC Pole	Weasel Conductor	RHS
		1100 Mtr.			
Total length of LT O/H Line (separate) line on 9.1 M high PCC poles = 1100 (1.1 km.) meters					

(e) 33 KV Overhead line (S/C)

Sl. No.	Chainage From – To	Line Length (in mtrs.)	Height & type of existing pole	Size of existing ACSR	Nos of existing SP/DP and TP/FP structures	Whether on LHS or RHS of Road
1	18+500 to 19+600	1100	11 Mtr. PCC Pole 365 Kg.	AAAC 50 m ²	SP-26 nos.	LHS
2	20+100 to 22+000	1900	11 Mtr. PCC Pole 365 Kg.	AAAC 50 m ²	SP-40 nos.	LHS
3	26+150 to 33+400	7250	11 Mtr. PCC Pole 365 Kg.	AAAC 50 m ²	SP-117 nos.	RHS
4	38+400 to 38+900	500	11 Mtr. PCC Pole 365 Kg.	AAAC 50 m ²	SP-12 nos.	LHS
5	52+200 to 55+750	3550	11 Mtr. PCC Pole 365 Kg.	AAAC 50 m ²	SP-71 nos.	RHS
6	60+150 To	200	11 Mtr. PCC Pole 365 Kg.	AAAC 50 m ²	SP-8 nos.	RHS



Four laning of NH-163 from Hyderabad (ORR Appa Junction) (Design Km 14.000/Existing Km 14.000) to Manneguda (Design Km 60.405/Existing Km 59.500) (Design Length = 46.405 Km) in the State of Telangana under Bharatmala Pariyojna on Hybrid Annuity Mode

60+350				
	14500 mtr.			248 nos.
Total length of 33 KV O/H line on 11.0 Mtr. high PCC Poles obstructing ROW –14500 Meter (4.5 km.)				

(f) 33 KV Overhead (D/C) Lines

Sl. No.	Chainage From – To	Line Length (in mtrs.)	Height & type of existing pole	Size of existing ACSR	Nos of existing SP/DP and TP/FP structures	Whether on LHS or RHS of Road
1	26+100 To 30+800	4700	M+3 type Towers	AAAC-100 sq.mtr. DOG Conductor	SP- 82 nos.	LHS
2	28+260 To 29+300	1000	M +6 type Towers	AAAC 100 Sq.mtr. DOG Conductor	SP-22 nos.	LHS
Total Length of 33 KV O/H D/C Line on M+3 & M+6 towers obstructing ROW = 5700 Meters (5.7 km.)						

(g) 33 KV Underground along the highway size 3C X 400 sq. mm.

1	28+100 to 28+350	350 Mtr.		33 KV cable size 3C X400 sq.mm HT Cable	SP-2 nos.	LHS
2	28+200 To 28+300	100 Mtr.		33 KV cable size 3C X400 sq.mm HT Cable	SP-2 nos.	LHS

(h) Details of existing LT Overhead Lines crossing the road

Sl. No.	Chainage No.	Type of Line whether LT, 11 KV and 33 KV	Existing Conductor Size	Level difference between GL and Road revised road formation level (FRL)	ROW in Meters
1	19+230	LT	Weasel	1.5 Mtr.	60 Mtr.
2	Bypass	LT	Weasel	5.5 Mtr.	60 Mtr.
3	Bypass	LT	Weasel	5.5 Mtr.	60 Mtr.
4	21+900	LT	Weasel		60 Mtr.
5	Bypass	LT	Weasel	5.5 Mtr.	60 Mtr.
6	Bypass	LT	Weasel	5.5 Mtr.	60 Mtr.
7	Bypass	LT	Weasel	5.5 Mtr.	60 Mtr.
8	Bypass	LT	Weasel	5.5 Mtr.	60 Mtr.
9	Bypass	LT	Weasel	5.5 Mtr.	60 Mtr.
10	Bypass	LT	Weasel	5.5 Mtr.	60 Mtr.
11	Bypass	LT	Weasel	5.5 Mtr.	60 Mtr.
12	Bypass	LT	Weasel	5.5 Mtr.	60 Mtr.
13	26+200	LT	ABC	5.5 Mtr.	60 Mtr.
14	28+000	LT	ABC	3.0 Mtr.	60 Mtr.

Four laning of NH-163 from Hyderabad (ORR Appa Junction) (Design Km 14.000/Existing Km 14.000) to Manneguda (Design Km 60.405/Existing Km 59.500) (Design Length = 46.405 Km) in the State of Telangana under Bharatmala Pariyojna on Hybrid Annuity Mode

15	28+300	LT	ABC	1.0 Mtr.	60 Mtr.
16	Bypass	LT	ABC		60 Mtr.
17	Bypass	LT	ABC		60 Mtr.
18	47+350	LT	ABC	1.5 Mtr.	60 Mtr.
19	52+200	LT	Weasel	4.0 Mtr.	60 Mtr.
20	55+250	LT	ABC	1.0 Mtr.	60 Mtr.
Total nos. of existing LT/OH lines crossing the existing road obstructing redefined ROW = 20 nos.					

(i) Details of Existing 11 KV O/H Lines crossing the road

Sl. No.	Chainage No.	Type of Line whether LT, 11 KV and 33 KV	Existing Conductor Size	Level difference between GL and FRL	ROW in Meters
1	18+800	11 KV	AAA – 50 m ²		60 Mtr.
2	19+600	11 KV	AAA – 50 m ²		60 Mtr.
3	Bypass	11 KV	AAA – 50 m ²	5.5 Mtr.	60 Mtr.
4	Bypass	11 KV	AAA – 50 m ²	5.5 Mtr.	60 Mtr.
5	20+150	11 KV	AAA – 50 m ²		60 Mtr.
6	20+400	11 KV	AAA – 50 m ²	3.0 Mtr.	60 Mtr.
7	20+700	11 KV	AAA – 50 m ²	2.0 Mtr.	60 Mtr.
8	20+850	11 KV	AAA – 50 m ²		60 Mtr.
9	21+200	11 KV	AAA – 50 m ²		60 Mtr.
10	21+500	11 KV	AAA – 50 m ²		60 Mtr.
11	21+800	11 KV	AAA – 50 m ²		60 Mtr.
12	22+000	11 KV	AAA – 50 m ²		60 Mtr.
13	Bypass	11 KV	AAA – 50 m ²	5.5 Mtr.	60 Mtr.
14	Bypass	11 KV	AAA – 50 m ²	5.5 Mtr.	60 Mtr.
15	Bypass	11 KV	AAA – 50 m ²	5.5 Mtr.	60 Mtr.
16	Bypass	11 KV	AAA – 50 m ²	5.5 Mtr.	60 Mtr.
17	Bypass	11 KV	AAA – 50 m ²	5.5 Mtr.	60 Mtr.
18	Bypass	11 KV	AAA – 50 m ²	5.5 Mtr.	60 Mtr.
19	Bypass	11 KV	AAA – 50 m ²	5.5 Mtr.	60 Mtr.
20	Bypass	11 KV	AAA – 50 m ²	5.5 Mtr.	60 Mtr.
21	Bypass	11 KV	AAA – 50 m ²	5.5 Mtr.	60 Mtr.
22	Bypass	11 KV	AAA – 50 m ²	5.5 Mtr.	60 Mtr.
23	26+150	11 KV	AAA – 50 m ²		60 Mtr.
24	26+500	11 KV	AAA – 50 m ²		60 Mtr.
25	26+800	11 KV	AAA – 50 m ²		60 Mtr.
26	27+000	11 KV	AAA – 50 m ²		60 Mtr.
27	27+355	11 KV	AAA – 50 m ²		60 Mtr.
28	27+550	11 KV	AAA – 50 m ²	3.0 Mtr	60 Mtr.
29	27+650	11 KV	AAA – 50 m ²	3.0 Mtr	60 Mtr.
30	28+400	11 KV	AAA – 50 m ²	1.5 Mtr	60 Mtr.
31	29+250	11 KV	AAA – 50 m ²		60 Mtr.

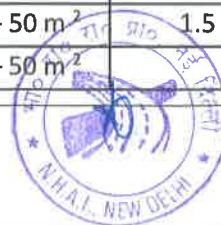

Four laning of NH-163 from Hyderabad (ORR Appa Junction) (Design Km 14.000/Existing Km 14.000) to Manne-guda (Design Km 60.405/Existing Km 59.500) (Design Length = 46.405 Km) in the State of Telangana under Bharatmala Pariyojna on Hybrid Annuity Mode

32	29+400	11 KV	AAA – 50 m ²		60 Mtr.
33	29+600	11 KV	AAA – 50 m ²		60 Mtr.
34	29+900	11 KV	AAA – 50 m ²		60 Mtr.
35	30+100	11 KV	AAA – 50 m ²		60 Mtr.
36	30+350	11 KV	AAA – 50 m ²		60 Mtr.
37	30+500	11 KV	AAA – 50 m ²	3.0 Mtr.	60 Mtr.
38	31+200	11 KV	AAA – 50 m ²		60 Mtr.
39	31+600	11 KV	AAA – 50 m ²		60 Mtr.
40	32+100	11 KV	AAA – 50 m ²		60 Mtr.
41	32+350	11 KV	AAAC DOG Conductor		60 Mtr.
42	32+450	11 KV	AAAC DOG Conductor		60 Mtr.
43	38+400	11 KV	AAAC DOG Conductor		60 Mtr.
44	38+550	11 KV	AAAC DOG Conductor		60 Mtr.
45	38+770	11 KV	AAAC DOG Conductor		60 Mtr.
46	38+900	11 KV	AAAC DOG Conductor		60 Mtr.
47	Bypass	11 KV	AAAC DOG Conductor	5.5 Mtr.	60 Mtr.
48	Bypass	11 KV	AAAC DOG Conductor	5.5 Mtr.	60 Mtr.
49	Bypass	11 KV	AAAC DOG Conductor	5.5 Mtr.	60 Mtr.
50	Bypass	11 KV	AAAC DOG Conductor	5.5 Mtr.	60 Mtr.
51	Bypass	11 KV	AAAC DOG Conductor	5.5 Mtr.	60 Mtr.
52	Bypass	11 KV	AAAC DOG Conductor	5.5 Mtr.	60 Mtr.
53	45+100	11 KV	AAAC DOG Conductor		60 Mtr.
54	45+500	11 KV	AAAC DOG Conductor	3.0 Mtr.	60 Mtr.
55	45+600	11 KV	AAAC DOG Conductor	3.0 Mtr.	60 Mtr.
56	45+800	11 KV	AAAC DOG Conductor	4.0 Mtr.	60 Mtr.
57	46+650	11 KV	AAAC DOG Conductor		60 Mtr.



Four laning of NH-163 from Hyderabad (ORR Appa Junction) (Design Km 14.000/Existing Km 14.000) to Manneguda (Design Km 60.405/Existing Km 59.500) (Design Length = 46.405 Km) in the State of Telangana under Bharatmala Pariyojna on Hybrid Annuity Mode

58	46+750	11 KV	AAAC DOG Conductor		60 Mtr.
59	47+300	11 KV	AAAC DOG Conductor		60 Mtr.
60	49+500	11 KV	AAAC DOG Conductor	1.5 Mtr.	60 Mtr.
61	50+000	11 KV	AAAC DOG Conductor		60 Mtr.
62	50+900	11 KV	AAAC DOG Conductor		60 Mtr.
63	51+400	11 KV	AAAC DOG Conductor		60 Mtr.
64	52+600	11 KV	AAAC DOG Conductor	3.0	60 Mtr.
65	53+000	11 KV	AAAC DOG Conductor		60 Mtr.
66	53+600	11 KV	AAAC DOG Conductor		60 Mtr.
67	53+700	11 KV	AAAC DOG Conductor		60 Mtr.
68	53+900	11 KV	AAAC DOG Conductor		60 Mtr.
69	54+200	11 KV	AAAC DOG Conductor		60 Mtr.
70	55+150	11 KV	AAAC DOG Conductor	3.0	60 Mtr.
71	55+750	11 KV	AAAC DOG Conductor		60 Mtr.
72	56+250	11 KV	AAAC DOG Conductor		60 Mtr.
73	56+950	11 KV	AAAC DOG Conductor	4.0	60 Mtr.
74	57+900	11 KV	AAAC DOG Conductor		60 Mtr.
75	59+450	11 KV	AAAC DOG Conductor		60 Mtr.
76	59+650	11 KV	AAAC DOG Conductor		60 Mtr.
77	59+750	11 KV	AAAC DOG Conductor		60 Mtr.
78	60+150	11 KV	AAAC DOG Conductor		60 Mtr.
79	60+150	11 KV	AAAC DOG Conductor		60 Mtr.



Four laning of NH-163 from Hyderabad (ORR Appa Junction) (Design Km 14.000/Existing Km 14.000) to Manneguda (Design Km 60.405/Existing Km 59.500) (Design Length = 46.405 Km) in the State of Telangana under Bharatmala Pariyojna on Hybrid Annuity Mode

80	60+150	11 KV	AAAC DOG Conductor	60 Mtr.
Total number of 11 KV O/H lines crossing the road and found infringing/ obstructing ROW = 80 nos.				

(j) Details of existing 33 KV Overhead (O/H) Lines Crossing the Road

Sl. No.	Chainage No.	Type of Line whether LT, 11 KV and 33 KV	Existing Conductor Size	Level difference between GL and Road revised road formation level (FRL)	ROW in Meters
1	22+000	33 KV	AAA – 100 m ² DOG Conductor		60 Mtr.
2			AAA – 100 m ² DOG Conductor		60 Mtr.
3	23+320	33 KV	AAA – 100 m ² DOG Conductor		60 Mtr.
4	30+800	33 KV	AAA – 100 m ² DOG Conductor		60 Mtr.
5	38+900	33 KV	AAA – 100 m ² DOG Conductor		60 Mtr.
6	Bypass	33 KV	AAA – 100 m ² DOG Conductor	5.5 Mtr.	60 Mtr.
7	Bypass	33 KV	AAA – 100 m ² DOG Conductor	5.5 Mtr.	60 Mtr.
8	Bypass	33 KV	AAA – 100 m ² DOG Conductor	5.5 Mtr.	60 Mtr.
9	Bypass	33 KV	AAA – 100 m ² DOG Conductor	5.5 Mtr.	60 Mtr.
10	52+200	33 KV	AAA – 100 m ² DOG Conductor	3.0 Mtr.	60 Mtr.
11	60+150	33 KV	AAA – 100 m ² DOG Conductor		60 Mtr.
Total number of 33 KV O/H lines crossing the road but found infringing / obstructing ROW = 11 nos.					



Four laning of NH-163 from Hyderabad (ORR Appa Junction) (Design Km 14.000/Existing Km 14.000) to Manneguda (Design Km 60.405/Existing Km 59.500) (Design Length = 46.405 Km) in the State of Telangana under Bharatmala Pariyojna on Hybrid Annuity Mode

(k) Details of existing Distribution Transformers (DT's) infringing redefined ROW

Sl. No.	Chainage No.	DT Capacity	Whether Single Phase or 3 Phase	Whether on LHS or RHS of road	Type of arrangement/ placement of the DT
1	18+700	63 KVA	3 Phase	LHS	On Plinth
2	18+750	100 KVA	3 Phase	LHS	On Plinth
3	18+700	100 KVA	3 Phase	RHS	On Plinth
4	18+750	100 KVA	3 Phase	RHS	On Plinth
5	18+770	100 KVA	3 Phase	RHS	On Plinth
6	18+780	10 KVA	1 Phase	RHS	Pole Mounted
7	19+250	63 KVA	3 Phase	RHS	Pole Mounted
8	19+400	100 KVA	3 Phase	LHS	Pole Mounted
9	19+500	63 KVA	3 Phase	LHS	On Plinth
10	19+600	63 KVA	3 Phase	RHS	On Plinth
11	Bypass	63 KVA	3 Phase	RHS	On Plinth
12	20+350	63 KVA	3 Phase	LHS	On Plinth
13	20+400	63 KVA	3 Phase	RHS	On Plinth
14	21+200	63 KVA	3 Phase	RHS	On Plinth
15	21+800	63 KVA	3 Phase	LHS	On Plinth
16	21+900	63 KVA	3 Phase	LHS	On Plinth
17	23+500	100 KVA	3 Phase	RHS	On Plinth
18	27+355	10 KVA	1 Phase	RHS	Pole Mounted
19	27+355	10 KVA	1 Phase	RHS	Pole Mounted
20	27+355	10 KVA	1 Phase	RHS	On Plinth
21	27+355	10 KVA	1 Phase	RHS	On Plinth
22	27+550	63 KVA	3 Phase	RHS	On Plinth
23	27+650	100 KVA	3 Phase	RHS	On Plinth
24	27+650	63 KVA	3 Phase	RHS	On Plinth
25	29+600	63 KVA	3 Phase	RHS	On Plinth
26	29+900	100 KVA	3 Phase	RHS	On Plinth
27	30+350	100 KVA	3 Phase	RHS	On Plinth
28	30+500	100 KVA	3 Phase	RHS	On Plinth
29	31+200	63 KVA	3 Phase	RHS	On Plinth
30	31+600	10 KVA	1 Phase	LHS	On Plinth
31	32+350	10 KVA	1 Phase	LHS	Pole Mounted
32	32+350	10 KVA	1 Phase	LHS	On Plinth
33	32+350	10 KVA	1 Phase	LHS	Pole Mounted
34	45+200	63 KVA	3 Phase	RHS	Pole Mounted
35	45+200	25 KVA	3 Phase	RHS	On Plinth
36	46+650	63 KVA	3 Phase	RHS	On Plinth
37	46+750	63 KVA	3 Phase	RHS	On Plinth
38	49+600	100 KVA	3 Phase	RHS	On Plinth

Four laning of NH-163 from Hyderabad (ORR Appa Junction) (Design Km 14.000/Existing Km 14.000) to Manneguda (Design Km 60.405/Existing Km 59.500) (Design Length = 46.405 Km) in the State of Telangana under Bharatmala Pariyojna on Hybrid Annuity Mode

39	49+600	25 KVA	3 Phase	RHS	On Plinth
40	52+400	10 KVA	1 Phase	LHS	Pole Mounted
41	38+550	63 KVA	3 Phase	LHS	On Plinth
42	32+550	63 KVA	3 Phase	RHS	On Plinth
43	44+500	25 KVA	3 Phase	LHS	On Plinth
44	52+400	10 KVA	1 Phase	LHS	Pole Mounted
45	52+400	10 KVA	1 Phase	LHS	Pole Mounted
46	51+400	63 KVA	3 Phase	RHS	On Plinth
47	53+200	25 KVA	3 Phase	LHS	On Plinth
48	53+400	100 KVA	3 Phase	LHS	On Plinth
49	55+350	63 KVA	3 Phase	LHS	On Plinth
50	53+000	10 KVA	1 Phase	RHS	Pole Mounted
51	53+000	10 KVA	1 Phase	RHS	Pole Mounted
52	53+600	10 KVA	1 Phase	RHS	Pole Mounted
53	53+600	63 KVA	3 Phase	RHS	On Plinth
54	54+200	63 KVA	3 Phase	RHS	On Plinth
55	56+000	63 KVA	3 Phase	LHS	On Plinth
56	56+250	63 KVA	3 Phase	RHS	On Plinth
57	56+650	100 KVA	3 Phase	RHS	On Plinth
58	57+900	63 KVA	3 Phase	LHS	On Plinth

Abstract: Quantity of DTs rating wise found infringing/ obstructing ROW are as under:-

1. 10 KVA (Single Phase) – 15 nos.
2. 25 KVA (Three Phase) - 4 nos.
3. 63 KVA (Three Phase) - 26 nos.
4. 100 KVA (Three Phase) - 13 nos.

(ii) Water pipeline utilities

The site includes following water pipeline utilities.

Sl. No.	Chainage		LHS (off set)		RHS (off set)		Pipeline details			Remarks
	From	To	Toe line of the proposed 4 laning with reference to Centre Line of existing Carriageway	Pipeline laid with reference to Center Lane of existing road (in Mtrs.)	Toe line of the proposed 4 laning with reference to Centre Line of existing Carriageway	Pipeline laid with reference to Center Lane of existing road (in Mtrs.)	Diameter of the pipe (in Mtrs.)	Type / Class of the pipeline	Length (in Kms)	
1	14+000	14+100	6.8 to 9.03	18			0.2	DI K9	100	Not Affected
2	14+100	14+200	4.66 to 8.66	11.5			0.2	DI K9	100	Not Affected
3	14+200	14+300	6.76 to 8.83	13.5			0.2	DI K9	100	Not Affected

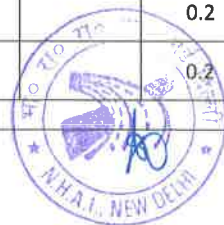

Four laning of NH-163 from Hyderabad (ORR Appa Junction) (Design Km 14.000/Existing Km 14.000) to Manneveda (Design Km 60.405/Existing Km 59.500) (Design Length = 46.405 Km) in the State of Telangana under Bharatmala Pariyojna on Hybrid Annuity Mode

4	14+300	14+400	7.63 to 8.89	12			0.2	DI K9	100	Not Affected
5	14+400	14+500	9.15 to 10.8	11			0.2	DI K9	100	Not Affected
6	14+500	14+600	10.78 to 11.5	11.5			0.2	DI K9	100	Not Affected
8	14+600	14+700	10.2 to 11.3	11			0.2	DI K9	100	Not Affected
9	14+700	15+050	8.4 to 10.8	10.5			0.2	DI K9	350	Not Affected
10	15+050	15+300	9.8 to 13.3	11.5			0.2	DI K9	250	Not Affected
11	15+300	16+150	7.6 to 10.1	11.5			0.2	DI K9	850	Not Affected
12	16+150	17+050	8.09 to 11.15	13.5			0.2	DI K9	900	Not Affected
13	17+050	17+535	8 to 10.1	15.5			0.2	DI K9	485	Not Affected
14	17+535	17+635	6.6 to 7.7	15.5			0.2	DI K9	100	Not Affected
15	17+635	17+735	6.9 to 7.8	12.5			0.2	DI K9	100	Not Affected
16	17+735	17+835	7.7 to 8	12.5			0.2	DI K9	100	Not Affected
17	17+835	18+454	7.9 to 8.5	12.5			0.2	DI K9	619	Not Affected
18	18+454	18+500	8.2 to 14.5	14.5			0.2	DI K9	46	Not Affected
19	18+500	19+500	16.6 to 33.5	11			0.2	DI K9	1000	Affected
20	20+200	20+500	11 to 32.6	11			0.2	DI K9	300	Affected
21	20+500	21+500	13.6 to 31.7	12			0.2	DI K9	1000	Affected
22	21+500	22+000	23.4 to 55.1	11			0.2	DI K9	500	Affected
23	24+450	24+450				Crossing	0.15	DI K9	0	Affected
24	25+000	25+000				Crossing	0.25	DI K9	0	Affected
25	26+300	26+500			12.5 to 41	12.5	0.3	DI K9	200	Affected
26	26+500	27+250			27.3 to 33.7	11.5	0.3	DI K9	750	Affected
27	27+250	27+400			32.4 to 33.9	11.5	0.3	DI K9	150	Affected
28	27+400	27+500			31.8 to 32.4	11.5	0.3	DI K9	100	Affected
29	27+500	27+580			31.8 to 37.7	11	0.3	DI K9	80	Affected
30	27+580	27+650			37.7 to 41.9	11.5	0.3	DI K9	70	Affected
31	27+650	27+790			40.8 to 42.9	12	0.3	DI K9	140	Affected
32	27+790	27+850			42.9 to 43.4	12.5	0.3	DI K9	60	Affected
33	27+850	27+950			43.1 to 46.1	13	0.3	DI K9	100	Affected
34	27+950	28+000			46.1 to 49.5	13.5	0.3	DI K9	50	Affected
35	28+000	28+050			49.5 to 55.3	14	0.3	DI K9	50	Affected
36	28+050	28+380			35.1 to 72.6	13.5	0.3	DI K9	330	Affected
37	28+380	28+650			28.7 to 35.1	13.7	0.3	DI K9	270	Affected
38	28+650	29+050			32.9 to 61.2	14.2	0.3	DI K9	400	Affected
39	29+050	29+580			22.8 to 36.9	14.5	0.3	DI K9	530	Affected
40	29+580	29+650			36.8 to 22.8	14.3	0.3	DI K9	70	Affected
41	29+650	30+050			8.9 to 11.3	11.5	0.3	DI K9	400	Not Affected
42	30+050	30+100			11 to 11.5	12.5	0.3	DI K9	50	Not Affected

Four laning of NH-163 from Hyderabad (ORR Appa Junction) (Design Km 14.000/Existing Km 14.000) to Manneveda (Design Km 60.405/Existing Km 59.500) (Design Length = 46.405 Km) in the State of Telangana under Bharatmala Pariyojna on Hybrid Annuity Mode

43	30+100	30+200			10.9 to 13.1	13	0.3	DI K9	100	Not Affected
44	30+200	30+300			11.7 to 16.3	14.5	0.3	DI K9	100	Not Affected
45	30+300	30+400			16.3 to 26.3	14	0.3	DI K9	100	Not Affected
46	30+400	30+500			25.2 to 27.1	14.5	0.3	DI K9	100	Not Affected
47	30+500	30+600			26.6 to 27.3	13	0.3	DI K9	100	Not Affected
48	30+600	30+700			27 to 29	11.5	0.3	DI K9	100	Not Affected
49	30+700	30+800			28.6 to 29.6	12.5	0.3	DI K9	100	Not Affected
50	30+800	30+820			28.2 to 28.6	11.5	0.3	DI K9	20	Not Affected
52	30+820	30+900			27.5 to 28.6	11.5	0.35	DI K7	80	Not Affected
53	30+900	31+000			28.6 to 31	13.5	0.35	DI K7	100	Not Affected
54	31+000	31+300			16 to 30.6	16	0.35	DI K7	300	Not Affected
55	31+300	31+420			0 to 12.5	13.5	0.35	DI K7	120	Affected
56	31+420	31+600			12.5 to 17.9	17	0.4	DI K7	180	Not Affected
57	31+600	31+850			17.9 to 41.4	15.5	0.4	DI K7	250	Affected
58	31+850	32+050			41.4 to 56.5	16.5	0.4	DI K7	200	Affected
59	32+050	32+110			56.5 to 62.06	15	0.4	DI K7	60	Affected
60	32+110	32+300			62.06 to 71.9	13	0.4	DI K7	190	Affected
61	32+300	32+500			46.4 to 70	14	0.4	DI K7	200	Affected
62	32+500	32+700			19.8 to 46.4	16	0.4	DI K7	200	Affected
63	32+700	32+900			8.5 to 15.5	15.5	0.4	DI K7	200	Not Affected
64	32+900	33+100			10.4 to 11	18	0.4	DI K7	200	Not Affected
65	33+100	33+300			9 to 11	18.5	0.4	DI K7	200	Not Affected
66	33+300	33+400			9 to 11	13.5	0.4	DI K7	100	Not Affected
67	33+400	33+500			9 to 11	12.5	0.4	DI K7	100	Not Affected
68	33+500	34+000			9 to 11	13.5	0.4	DI K7	500	Not Affected
69	34+000	34+500			8.9 to 12	12.5	0.4	DI K7	500	Not Affected
70	34+500	35+000			9.1 to 13.1	13	0.4	DI K7	500	Not Affected
71	35+000	35+650			6.4 to 12.8	12	0.4	DI K7	650	Not Affected
72	35+650	35+700			7.8 to 8.5	11.5	0.4	DI K7	50	Not Affected
73	35+700	36+350			7.4 to 28.3	11	0.4	DI K7	650	Not Affected
74	36+350	36+500			28.3 to 43.8	12	0.4	DI K7	150	Affected
75	36+500	36+750			25.4 to 47.8	12.5	0.4	DI K7	250	Affected
76	36+750	36+950			26 to 31.7	11	0.4	DI K7	200	Affected
77	36+950	37+050			4 to 30.6	12.5	0.4	DI K7	100	Affected



Four laning of NH-163 from Hyderabad (ORR Appa Junction) (Design Km 14.000/Existing Km 14.000) to Manneveda (Design Km 60.405/Existing Km 59.500) (Design Length = 46.405 Km) in the State of Telangana under Bharatmala Pariyojna on Hybrid Annuity Mode

78	37+050	37+250			11.5	11.5	0.4	DI K7	200	Not Affected
79	37+250	37+350			12	12	0.4	DI K7	100	Not Affected
80	37+350	37+500			13	13	0.4	DI K7	150	Not Affected
81	37+500	37+700			12.5	12.5	0.4	DI K7	200	Not Affected
82	37+700	37+800			12	12	0.4	DI K7	100	Not Affected
83	37+800	38+000			11.5	11.5	0.4	DI K7	200	Not Affected
84	38+000	38+200			13	13	0.4	DI K7	200	Not Affected
85	38+200	38+400			13.5	13.5	0.4	DI K7	200	Not Affected
86	38+400	38+550			15	15	0.4	DI K7	150	Not Affected
87	38+550	38+650			13	13	0.4	DI K7	100	Not Affected
88	38+650	38+800			12.5	12.5	0.4	DI K7	150	Not Affected
89	44+800	45+000	43.3 to 60.2	14.1			0.4	DI K7	200	Affected
90	45+000	45+200	27.8 to 41.7	13.8			0.4	DI K7	200	Affected
91	45+200	45+400	30.3 to 35.5	12.5			0.4	DI K7	200	Affected
92	45+400	45+600	30.4 to 34.2	12.8			0.4	DI K7	200	Affected
93	45+600	45+800	35 to 46.3	12.6			0.4	DI K7	200	Affected
94	45+800	46+000	46 to 54.1	12.9			0.4	DI K7	200	Affected
95	46+000	46+200	53.9 to 57	13.2			0.4	DI K7	200	Affected
96	46+200	46+400	57.2 to 60.7	14			0.4	DI K7	200	Affected
97	46+400	46+600	59.9 to 73.1	15.9			0.4	DI K7	200	Affected
98	46+600	46+800	37.1 to 67.2	16.2			0.4	DI K7	200	Affected
99	46+800	46+880	30.1 to 36.9	16.3			0.4	DI K7	80	Affected
100	46+880	47+800			23.1 to 54.8	15.3	0.3	DI K7	920	Affected
101	47+800	48+000			4.62 to 14.7	15.1	0.3	DI K7	200	Not Affected
102	48+000	48+200			12.8 to 15.4	15.4	0.3	DI K7	200	Not Affected
103	48+200	48+300			14.5 to 15.31	15.4	0.3	DI K7	100	Not Affected
104	48+300	48+400			16.06 to 25.16	15.4	0.3	DI K7	100	Affected
105	48+300	48+500			16.21 to 26.2	15.2	0.3	DI K7	200	Affected
106	48+500	48+600			10.95 to 15.01	15.2	0.3	DI K7	100	Not Affected
107	48+500	48+800			7.07 to 10.9	14.8	0.3	DI K7	300	Not Affected
108	48+800	49+000			6.5 to 7.6	14.4	0.3	DI K7	200	Not Affected
109	49+000	49+200			0 to 7	14.1	0.3	DI K7	200	Not Affected
110	49+200	49+350			0 to 9	15	0.3	DI K7	150	Not Affected
111	49+350	49+400			14 to 23.2	14	0.3	DI K7	50	Affected
112	49+400	49+600			26.1 to 42.7	14.5	0.3	DI K7	200	Affected
113	49+600	49+800			23.8 to 40.4	14.7	0.3	DI K7	200	Affected



Four laning of NH-163 from Hyderabad (ORR Appa Junction) (Design Km 14.000/Existing Km 14.000) to Manneguda (Design Km 60.405/Existing Km 59.500) (Design Length = 46.405 Km) in the State of Telangana under Bharatmala Pariyojna on Hybrid Annuity Mode

114	49+800	50+000			15.34	15.34	0.3	DI K7	200	Not Affected
115	50+000	50+100			15.5	15.5	0.3	DI K7	100	Not Affected
116	50+100	50+200			15.4	15.4	0.3	DI K7	100	Not Affected
117	50+200	50+300			16.3	16.3	0.3	DI K7	100	Not Affected
118	50+300	50+400			7.8 to 15.8	16.3	0.3	DI K7	100	Not Affected
119	50+400	50+600			6.1 to 7.4	15.2	0.3	DI K7	200	Not Affected
120	50+600	50+800			5.4 to 8.4	15.3	0.3	DI K7	200	Not Affected
121	50+800	51+000			7.2 to 9.7	14.9	0.3	DI K7	200	Not Affected
122	51+000	51+200			7.6 to 10.2	14.8	0.3	DI K7	200	Not Affected
123	51+200	51+400			8.3 to 10.5	14.4	0.3	DI K7	200	Not Affected
124	51+400	51+600			8.1 to 10.2	14.1	0.3	DI K7	200	Not Affected
125	51+600	51+800			7.8 to 9.6	13.9	0.3	DI K7	200	Not Affected
126	51+800	52+000			7.2 to 9.7	12.5	0.3	DI K7	200	Not Affected
127	52+000	52+140			7.8 to 12.23	12.8	0.3	DI K7	140	Not Affected
128	52+140	52+200			13.24 to 17.15	12.8	0.3	DI K7	60	Affected
129	52+200	52+300			17.9 to 21.11	12.8	0.25	DI K7	100	Affected
130	52+300	52+400			17.9 to 19	12.8	0.25	DI K7	100	Affected
131	52+400	52+500			15.4 to 18	12.5	0.25	DI K7	100	Affected
132	52+500	52+600			12.3 to 15.4	12.1	0.25	DI K7	100	Affected
133	52+600	52+700			13 to 20	12.6	0.25	DI K7	100	Affected
134	52+700	52+800			19.2 to 21.6	12.8	0.25	DI K7	100	Affected
135	52+800	52+900			21.8 to 22.7	13.3	0.25	DI K7	100	Affected
136	52+900	53+000			23.7 to 26.5	13.1	0.25	DI K7	100	Affected
137	53+000	53+100			26.5 to 27.5	12.8	0.25	DI K7	100	Affected
138	53+100	53+200			25.8 to 27.1	12.7	0.25	DI K7	100	Affected
139	53+200	53+300			27 to 28	12.7	0.25	DI K7	100	Affected
140	53+300	53+400			27.5 to 28.5	13.1	0.25	DI K7	100	Affected
141	53+400	53+500			26.7 to 27.3	16.3	0.18	8 Kg/Sqcm	100	Affected
142	53+500	53+600			12.8 to 26.4	16.5	0.18	8 Kg/Sqcm	100	Affected
143	53+600	53+700			0 to 8	16.4	0.18	8 Kg/Sqcm	100	Not Affected
144	53+700	53+800			0 to 2	16.3	0.18	8 Kg/Sqcm	100	Not Affected
145	53+800	53+900			4.3 to 10.6	16.2	0.18	8 Kg/Sqcm	100	Not Affected
146	53+900	54+000			10.73 to 11.5	16.1	0.18	8 Kg/Sqcm	100	Not Affected
147	54+000	54+100			8.93 to 10.7	15.7	0.18	8 Kg/Sqcm	100	Not Affected
148	54+100	54+200			6.5 to 8.4	15.1	0.18	8 Kg/Sqcm	100	Not Affected



Four laning of NH-163 from Hyderabad (ORR Appa Junction) (Design Km 14.000/Existing Km 14.000) to Mannegeuda (Design Km 60.405/Existing Km 59.500) (Design Length = 46.405 Km) in the State of Telangana under Bharatmala Pariyojna on Hybrid Annuity Mode

149	54+200	54+300			6.5 to 7.1	14.8	0.18	8 Kg/Sqcm	100	Affected (Toll Plaza)
150	54+300	54+400			6.6 to 8.3	14.6	0.18	8 Kg/Sqcm	100	
151	54+400	54+500			7.2 to 8.9	14.4	0.18	8 Kg/Sqcm	100	
152	54+500	54+600			5.9 to 6.9	15.1	0.18	8 Kg/Sqcm	100	
153	54+600	54+700			6.1 to 6.7	15.8	0.18	8 Kg/Sqcm	100	
154	54+700	54+800			6.6 to 7.8	16.2	0.18	8 Kg/Sqcm	100	Not Affected
155	54+800	54+900			7.2 to 8.7	16.1	0.18	8 Kg/Sqcm	100	Not Affected
156	54+900	55+000			8.9 to 10.5	15.9	0.18	8 Kg/Sqcm	100	Not Affected
157	55+000	55+100			8.7 to 10.3	16.2	0.18	8 Kg/Sqcm	100	Not Affected
158	55+100	55+200			9 to 16.7	16.1	0.18	8 Kg/Sqcm	100	Not Affected
159	55+200	55+300			15.9	15.9	0.18	8 Kg/Sqcm	100	Not Affected
160	55+300	55+400			16.1	16.1	0.18	8 Kg/Sqcm	100	Not Affected
161	55+400	55+500			15.8	15.8	0.18	8 Kg/Sqcm	100	Not Affected
162	55+500	55+600			14.8	14.8	0.18	8 Kg/Sqcm	100	Not Affected
163	55+600	55+700			13.4	13.4	0.18	8 Kg/Sqcm	100	Not Affected
164	55+700	55+800			15.7	15.7	0.18	8 Kg/Sqcm	100	Not Affected
165	55+800	55+850			16.2	16.2	0.18	8 Kg/Sqcm	50	Not Affected

Note : An overhead tank is located adjacent to existing ROW at km 46+850(RHS), as it is not likely to cause hindrance to road implementation project, thus not required to be shifted.

(iii) Municipal Water pipeline utilities

The site includes following municipal pipeline utilities.

Sl. No.	Chainage		Pipeline details			Remarks
	From	To	Diameter of the pipe (in Mtrs.)	Type / Class of the pipeline	Length (in Kms)	
1	18+000	19+700	0.180	HDPE 6kg	1.7	Affected
2	44+850	46+850	0.250	HDPE 6kg	2	Affected

Note :- Length/location/specification mentioned above is tentative and liable to change. The bidders are advised to assess the existing utilities at site with the help of latest technology. Variation in length/location and specifications shall not constitute Change of Scope.

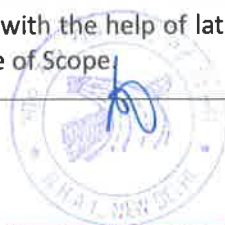

Four laning of NH-163 from Hyderabad (ORR Appa Junction) (Design Km 14.000/Existing Km 14.000) to Manneguda (Design Km 60.405/Existing Km 59.500) (Design Length = 46.405 Km) in the State of Telangana under Bharatmala Pariyojna on Hybrid Annuity Mode

Annex-II

(Schedule-A)

Dates for providing Right of Way

The dates on which the Authority shall provide Right of Way of construction zone to the Concessionaire on different stretches of the Site are stated below:

The Right of Way is being acquired and shall be provided to the Concessionaire on different stretches presented below:

Sl. No.	Design Chainage		PROW (m)
	From (km)	To (km)	
1	14	15	22
2	15	16	18.5
3	16	17	18.5
4	17	18	28
5	18	18.5	30
6	18.5	19.3	30
7	19.3	33	60
8	33	38	60
9	38	57.8	60
10	57.8	59.85	60
11	59.85	60.405	60

Note:

- The Authority shall provide the Right of Way on no less than 80% (Eighty percent) of the total length of Project Highway on Appointed date in compliance to clause 10.3 of Agreement.
- Additional land required for Toll Plazas, Interchanges, Underpasses, Truck Lay-byes, shall be provided to the Concessionaire as per Agreement.



165



Four laning of NH-163 from Hyderabad (ORR Appa Junction) (Design Km 14.000/Existing Km 14.000) to Manneguda (Design Km 60.405/Existing Km 59.500) (Design Length = 46.405 Km) in the State of Telangana under Bharatmala Pariyojna on Hybrid Annuity Mode

**ANNEX-III
(Schedule-A)**

Alignment Plans

The existing alignment of the project Highway shall be modified in the following sections as per the alignment plan indicated below :



- 1 The alignment of the Project Highway is enclosed in alignment plan. Finished road level indicated in the alignment plan shall be minimum requirement and treated as an approximate assessment. The Concessionaire shall design the Road profile of the project highway based on site/design requirement mentioned in Schedule D.
- 2 Traffic Signage plan of the Project Highway showing numbers & location of traffic signs is enclosed, which is minimum requirement. The Concessionaire shall, however, improve/upgrade upon the traffic signage plan as indicated in Annexure-III based on site/design requirement as per IRC: SP: 84-2014 & IRC: 67-2012.



Four laning of NH-163 from Hyderabad (ORR Appa Junction) (Design Km 14.000/Existing Km 14.000) to Manneguda (Design Km 60.405/Existing Km 59.500) (Design Length = 46.405 Km) in the State of Telangana under Bharatmala Pariyojna on Hybrid Annuity Mode

ANNEX -IV

(Schedule-A)

Environmental Clearances

Environmental Clearance is not required for the subject project.



Four laning of NH-163 from Hyderabad (ORR Appa Junction) (Design Km 14.000/Existing Km 14.000) to Manneguda (Design Km 60.405/Existing Km 59.500) (Design Length = 46.405 Km) in the State of Telangana under Bharatmala Pariyojna on Hybrid Annuity Mode

SCHEDULE- B
(See Clause 2.1)

DEVELOPMENT OF PROJECT HIGHWAY

1. Development of the Project Highway

Development of the Project Highway shall include detailed design including plan & profile within available proposed ROW and construction of the Project Highway as described in this Schedule-B and Schedule-C. The alignment plans of the Project Highway are given in Annex-III of Schedule A which is minimum requirement and are for guidance only. The proposed plan & profile, locations of different structures/drains/service & slip road/RE walls, chainages of different structures/drains/service & slip road/RE walls, length of different structures/drains/service & slip road/RE walls etc. of the project highway as indicated in the Schedule A, Schedule B, Schedule C and their Annexures shall be treated as an approximate assessment and as minimum requirement. Based on site/design requirement, the Concessionaire shall finalize Detailed Project Report (DPR) including plan & profile of the Project Highway based on site/design requirement and submit the same to Authority & Independent Engineer for acceptance, before the start of the execution of project. Any changes in the finally accepted DPR in respect of the proposed provision in Schedule B and Schedule C shall not constitute a change of scope, save and except any variations arising out of a change of scope expressly undertaken in accordance with the provision of Article 16.

Based on accepted DPR including Plan & profile prepared by the Concessionaire, the detailed work program prepared with network method (PERT/CPM) shall be prepared along with commensurate deployment of all resources and got approved from Independent Engineer before start of civil work. Any required changes in scope of work given in Schedule B and Schedule C, including any variation in standard, shall be finalized by both the parties before start of actual civil work.

Requirement specifically mentioned in Schedule B & C shall prevail over general requirements given in Manual mentioned in Schedule D.

1 Rehabilitation and Augmentation

Rehabilitation and augmentation shall include Four Lane with Paved shoulders configuration as described in Annex-I of this Schedule-B and in Schedule-C.

2 Specifications and Standards

The Project Highway shall be designed and constructed in conformity with the Specifications and Standards specified in Annex-I of Schedule-D.



**Annex-I
(Schedule-B)**

Description of Four Lane with Paved shoulders

1 Development of the Project Highway

The Project Highway shall generally follow the horizontal alignment shown in the plan specified in Annex III of Schedule-A, unless otherwise specified by the Authority. Notwithstanding anything to the contrary contained in this Agreement or IRC:SP:84-2014, the proposed plan & profile, locations of different structures/drains/service & slip road/RE walls, chainages of different structures/drains/service & slip road/RE walls, length of different structures/drains/service & slip road/RE walls etc. of the project highway as indicated in the Schedule A, Schedule B, Schedule C and their Annexures shall be treated as an approximate assessment and as minimum requirement. Based on site/design requirement, the Concessionaire shall finalise Detailed Project Report (DPR) including plan & profile of the project highway and submit the same to Authority & its Engineer for acceptance, before the start of the execution of project. Any changes in the finally accepted DPR in respect of the proposed provision in Schedule B and Schedule C shall not constitute a change of scope, save and except any variations arising out of a change of scope expressly undertaken in accordance with the provision of Article 16.

1.1 Width Of Carriageway

- 1.1.1 Four-Lane with paved shoulders shall be undertaken. The paved carriageway shall be as specified in the Para 4.3 of this Annex-I of the Schedule-B
- 1.1.2 The built-up areas along the alignment is mentioned at the appropriate place.
- 1.1.3 Except as otherwise provided in this Agreement, the width shall be adjusted to fit into appropriate plans and cross sections developed in accordance with TCS enclosed.
- 1.1.4 Except as otherwise provided in this Agreement, but subject to provisions of Annex –I of this Schedule–B, the width of the paved carriageway shall conform to Section 1.1.1 of Schedule B.
- 1.1.5 The entire cross-sectional elements shall be accommodated in the available/proposed ROW. If required, suitable retaining structures shall be provided to accommodate the highway cross section within the available/ proposed ROW and the same shall not constitute a Change of Scope, save and except any variations in the length arising out of a Change of Scope expressly undertaken in accordance with the provisions of Article 16.

2 Geometric Design and General Features:

- 2.1 General: Geometric design and general features of the Project Highway shall be in accordance with Section 2 of the manual.

2.2 Design Speed: The project road shall be designed for 100 Kmph for plain/rolling terrain.

3 Specifications and Standards

The Project Highway shall be constructed in conformity with the Specifications and Standards specified in Annex – I of Schedule – D.

4 Other Features of Four Laning



Four laning of NH-163 from Hyderabad (ORR Appa Junction) (Design Km 14.000/Existing Km 14.000) to Mannegeuda (Design Km 60.405/Existing Km 59.500) (Design Length = 46.405 Km) in the State of Telangana under Bharatmala Pariyojna on Hybrid Annuity Mode

4.1 Realignments: The existing road shall be improved to the standards as specified in the manual at the following locations:

Sl. No	Stretch (Existing Chainage)		Stretch (Design Chainage)		Design Length (km)
	From (Km)	To (Km)	From (Km)	To (Km)	
1	19.490	20.300	19+500	20+225	0.725

4.2 Bypasses: The existing road shall be bypassed to the standards as specified in the manual at the following locations:

Sl. No	Name of Bypass	Existing Chainage		Design Chainage		Design Length (km)
		From (km)	To (km)	From (km)	To (km)	
1	Moinabad Bypass	22+000	26+120	21+950	26+300	4.35
2	Chevella Bypass	38+650	44+120	38+700	45+060	6.36

4.3 Cross-Sections Type along the Project Highway

The Project Highway shall be constructed to four lane configuration for the Project length. Typical cross sections required to be developed in different segments of the project highway are given below.

Sl. No.	Design Chainage in Km		Length in m	New	Remarks
	From	To			
1	14+000	18+500	4500	Fig. 2.4A	Murgavani National Park
2	18+500	19+600	1100	Fig. 2.6B	Urban Area
3	19+600	20+145	545	Fig. 2.6A	Approach
4	20+145	20+170	25	Fig. 7.8	VUP
5	20+170	20+500	330	Fig. 2.6A	Approach
6	20+500	21+770	1270	Fig. 2.2C	
7	21+770	22+320	550	Fig. 2.6A	Approach
8	22+320	22+345	25	Fig. 7.8	VUP
9	22+345	22+670	325	Fig. 2.6A	Approach
10	22+670	24+400	1730	Fig. 2.2E	Moinabad Bypass
11	24+400	25+044	644	Fig. 2.6A	Approach
12	25+044	25+059	15	Fig. 7.8	VUP
13	25+059	26+070	1011	Fig. 2.6A	Approach
14	26+070	26+095	25	Fig. 7.8	VUP
15	26+095	26+420	325	Fig. 2.6A	Approach
16	26+420	27+580	1160	Fig. 2.2C	
17	27+580	28+018	438	Fig. 2.6A	Approach
18	28+018	28+033	15	Fig. 7.8	VUP
19	28+033	28+380	347	Fig. 2.6A	Approach
20	28+380	28+610	230	Fig. 2.2C	
21	28+610	28+970	360	Fig. 2.2A	
22	28+970	29+570	600	Fig. 2.2C	
23	29+570	30+330	760	Fig. 2.2B	
24	30+330	30+824	494	Fig. 2.6A	Approach



Four laning of NH-163 from Hyderabad (ORR Appa Junction) (Design Km 14.000/Existing Km 14.000) to Manneveda (Design Km 60.405/Existing Km 59.500) (Design Length = 46.405 Km) in the State of Telangana under Bharatmala Pariyojna on Hybrid Annuity Mode

Sl. No.	Design Chainage in Km		Length in m	New	Remarks
	From	To			
25	30+824	30+836	12	Fig. 7.8	LVUP
26	30+836	31+230	394	Fig. 2.6A	Approach
27	31+230	31+600	370	Fig. 2.2B	
28	31+600	32+186	586	Fig. 2.6A	Approach
29	32+186	32+198	12	Fig. 7.8	LVUP
30	32+198	32+800	602	Fig. 2.6A	Approach
31	32+800	33+015	215	Fig. 2.6A	Approach
32	33+015	33+393	378	Fig. 2.6A (1)	Approach
33	33+393	33+408	15	Fig. 7.8	VUP
34	33+408	34+150	742	Fig. 2.6A (1)	Approach
35	34+150	36+100	1950	Fig. 2.2A (1)	
36	36+100	36+614	514	Fig. 2.6A (1)	Approach
37	36+614	36+626	12	Fig. 7.8	LVUP
38	36+626	37+100	474	Fig. 2.6A (1)	Approach
39	37+100	38+020	920	Fig. 2.2A (1)	
40	38+020	38+200	180	Fig. 2.2B	
41	38+200	39+120	920	Fig. 2.6A	Approach
42	39+120	39+145	25	Fig. 7.8	VUP
43	39+145	39+700	555	Fig. 2.6A	Approach
44	39+700	40+670	970	Fig. 2.2E	Chevella Bypass
45	40+670	41+120	450	Fig. 2.6A	Approach
46	41+120	41+145	25	Fig. 7.8	VUP
47	41+145	41+800	655	Fig. 2.6A	Approach
48	41+800	42+300	500	Fig. 2.2E	
49	42+300	42+340	40	Fig. 7.2A	MNB at 42+320
50	42+340	42+895	555	Fig. 2.2E	
51	42+895	42+905	10	Fig. 7.2B	MNB at 42+900
52	42+905	44+480	1575	Fig. 2.6A	Approach
53	44+480	44+505	25	Fig. 7.8	VUP
54	44+505	45+050	545	Fig. 2.6A	Approach
55	45+050	45+620	570	Fig. 2.2B	
56	45+620	46+630	1010	Fig. 2.6A	Approach
57	46+630	46+645	15	Fig. 7.8	VUP
58	46+645	47+300	655	Fig. 2.6A	Approach
59	47+300	47+730	430	Fig. 2.2C	
60	47+730	47+930	200	Fig. 2.2A	
61	47+930	48+280	350	Fig. 2.2B	
62	48+280	48+430	150	Fig. 2.2D	
63	48+430	49+030	600	Fig. 2.2B	
64	49+030	49+550	520	Fig. 2.2A	
65	49+550	49+963	413	Fig. 2.6A	Approach
66	49+963	49+975	12	Fig. 7.8	LVUP



Four laning of NH-163 from Hyderabad (ORR Appa Junction) (Design Km 14.000/Existing Km 14.000) to Manneguda (Design Km 60.405/Existing Km 59.500) (Design Length = 46.405 Km) in the State of Telangana under Bharatmala Pariyojna on Hybrid Annuity Mode

Sl. No.	Design Chainage in Km		Length in m	New	Remarks
	From	To			
67	49+975	50+350	375	Fig. 2.6A	Approach
68	50+350	52+080	1730	Fig. 2.2B	
69	52+080	52+480	400	Fig. 2.2D	
70	52+480	52+650	170	Fig. 2.2B	
71	52+650	53+292	642	Fig. 2.6A	Approach
72	53+292	53+304	12	Fig. 7.8	LVUP
73	53+304	53+600	296	Fig. 2.6A	Approach
74	53+600	53+830	230	Fig. 2.2A	
75	53+830	55+180	1350	Fig. 2.2B	
76	55+180	55+733	553	Fig. 2.6A	Approach
77	55+733	55+745	12	Fig. 7.8	LVUP
78	55+745	56+130	385	Fig. 2.6A	Approach
79	56+130	57+350	1220	Fig. 2.2B	
80	57+350	57+815	465	Fig. 2.6A	Approach
81	57+815	57+908	93	Fig. 2.6A (1)	Approach
82	57+908	57+920	12	Fig. 7.8	LVUP
83	57+920	58+290	370	Fig. 2.6A (1)	Approach
84	58+290	59+400	1110	Fig. 2.2A (1)	
85	59+400	59+749	349	Fig. 2.6A (1)	Approach
86	59+749	59+761	12	Fig. 7.8	LVUP
87	59+761	59+864	103	Fig. 2.6A (1)	Approach
88	59+864	60+100	236	Fig. 2.6A	Approach
89	60+100	60+405	305	Fig. 2.2D	
Total Length (Km)			46405		

For Typical cross section figures refer Annex-II of Schedule-B.

Note:

- Any variations in the lengths specified in the above table shall not constitute a Change of Scope, save and except any variations in the length arising out of a Change of Scope expressly undertaken in accordance with the provisions of Article 16.
- Lengths mentioned in the above list for cross section types concerned to structures are inclusive of structure length.
- Retaining wall/ RE wall shall be provided as indicated in TCS above.
- Retaining wall/ Toe wall to be provided where ROW is restricted which is deemed to be included in the scope.
- Chainages may be adjusted according to location of structures as per drawings.
- The requirement of kerb in the median for surface drainage at super-elevated portions and approaches to structures shall be finalized in consultation with Independent Engineer/NHAI.
- Fig. 2.2A, 2.2B, 2.2C, 2.2D and 2.2 A(1) mentioned in above table are modified typical cross section based on Fig 2.4 of manual (4 laning manual - IRC SP:84-2014) and same is appended in schedule D of this Schedules
- Fig. 2.6A, 2.6A (1) and 2.6B mentioned in above table are modified typical cross section based on Fig 2.6 of manual (4 laning manual - IRC SP: 84-2014) and same is appended in schedule D of this Schedules.

Four laning of NH-163 from Hyderabad (ORR Appa Junction) (Design Km 14.000/Existing Km 14.000) to Manneguda (Design Km 60.405/Existing Km 59.500) (Design Length = 46.405 Km) in the State of Telangana under Bharatmala Pariyojna on Hybrid Annuity Mode

9. Fig. 2.4A mentioned in above table are modified typical cross section based on Fig 2.4 of manual (4 laning manual - IRC SP: 84-2014) and same is appended in schedule D of this Schedules.
10. Fig. 7.8 mentioned in above table are modified typical cross section based on Fig 7.8 of manual (4 laning manual – IRC SP: 84-2014) and same is appended in schedule D of this Schedules.
11. Carriageway width tapering shall be provided as per IRC-SP-84-2014 Clause no 2.5.4.
12. Intermediate Sight distance shall be followed for vertical curves.
13. Cross sections mentioned above is indicative and shall be decided as per project requirement and availability of ROW. No COS shall be admissible on this account.
Typical cross section 7.2B mentioned in above table is modified based on Fig 7.2B of manual (4 laning manual – IRC SP: 84-2014) and same is mentioned in schedule D.

4.4 Alignment Plan and Longitudinal Section

The alignment plan and vertical profile of complete project Highway is given at Annex-III of Schedule-A.

The Plan and profile of project highway is tentative and cannot be considered as design plan & profile. The actual design of plan and profile shall be carried out by concessionaire following IRC-SP 84-2014 and adopted vertical profile shall be designed for ISD except for locations with land constraints and with the approval of Independent Engineer. Horizontal geometry shall be within the land (ROW) provided by the authority as per approval of IE. There shall not be any COS/variation due to addition in length of approaches, earthwork, its RE wall, drain, slip road, accelerating/decelerating lane, foot path, separator etc. while adopting ISD as design standard throughout the project length. Further, bottom of the Sub-grade for embankment/fill portion shall be higher of the following:

- (a) 1.00 m above HFL data (100 years or available) from CWC, irrigation department, local enquiry.
- (b) 1.50m above existing GL.

4.5 Built up Area

The project Highway passes through the following built up areas

Sl. No.	Design Ch:		Village Name
	From	To	
1	14+150	14+300	Near ORR
2	18+000	19+300	Aziz Nagar
3	19+300	20+600	Himayat Nagar
4	32+100	32+450	Tholkatta
5	52+250	52+500	Aloor II

5 Pavement Design

- i) Pavement design shall be carried out in accordance with Section 5 of the Manual.

Flexible pavement for main carriageway shall be designed for minimum design traffic of 30 MSA for a minimum design period of 15 years with Design CBR of 10%. However, minimum thickness of Subgrade, Granular Sub-Base, Wet-Mix Macadam, DBM and BC in flexible pavement shall be 500 mm, 200 mm, 250 mm, 80 mm and 40 mm respectively.

Flexible pavement for slip roads and service roads shall be designed for minimum design traffic of 10MSA. However, minimum thickness provided for slip roads and service roads shall be 500 mm

Four laning of NH-163 from Hyderabad (ORR Appa Junction) (Design Km 14.000/Existing Km 14.000) to Manneguda (Design Km 60.405/Existing Km 59.500) (Design Length = 46.405 Km) in the State of Telangana under Bharatmala Pariyojna on Hybrid Annuity Mode

subgrade, 200 mm GSB, 250 mm WMM, 50 mm DBM and 40 mm BC.

Rigid Pavement shall be provided at Toll Plaza. However, minimum thickness of subgrade, GSB, DLC and PQC shall be 500 mm, 150 mm, 150 mm and 280mm respectively.

Paver blocks shall be considered for truck lay byes. However, minimum thickness of subgrade, GSB, WBM/WMM Base, Sand Bed and Paver Blocks shall be 500 mm, 200 mm, 250 mm, 40 mm and 100 mm respectively. The composition of the flexible pavement for Bus-Bays shall be same as that of main carriageway.

Overlay for the section of D.Ch. 14+000 to D.Ch. 18+500 in the Mrugavani National Park area for a minimum design traffic of 30MSA, and the minimum thickness provided in the section as DBM, and BC shall be 50mm, and 40mm respectively.

ii) **Type of pavement**

Flexible Pavement shall be provided for the entire project highway including bypasses, realignments, slip roads and service roads except at Toll Plaza Location where rigid pavement shall be provided.

(iii) **Design Requirements** shall be specified in the manual.

(iv) **Reconstruction of the stretches:** Total project stretch of the existing road shall be reconstructed, except at Mrugavani National Park D.Ch. 14+000 to D. Ch. 18+500.

6 Intersections and Grade Separators

6.1 At grade intersections

At grade intersections shall be provided with the intersecting roads at the following locations.

(a) **Major Junctions:**

Sl. No.	Design Chainage in Km	Existing Chainage in Km	Type of Junction	Category of Road	Leads To		Remarks
					LHS	RHS	
1	22+335	-	3-legged	City road	-	Moinabad	VUP
2	26+084	-	3-legged	City road	-	Moinabad	VUP
3	39+154	-	3-legged	City road	-	Chevella	VUP
4	44+511	-	3-legged	City road	-	Chevella	VUP

(b) **Minor Junctions:**

Sl. No.	Design Chainage in Km	Existing Chainage in Km	Type of Junction	Category of Road	Leads To		Remarks
					LHS	RHS	
1	14+210	14.21	3-legged	ORR service road	-	Narsing to appa service	
2	14.580	14.58	3-legged	ORR service road		Appa Service road	
3	15+200	15.20	3-legged	City road	Aziz nagar	-	
4	17+280	17.275	3-legged	City road	Aziz nagar	Gandhipet	



Four laning of NH-163 from Hyderabad (ORR Appa Junction) (Design Km 14.000/Existing Km 14.000) to Manne-guda (Design Km 60.405/Existing Km 59.500) (Design Length = 46.405 Km) in the State of Telangana under Bharatmala Pariyojna on Hybrid Annuity Mode

Sl. No.	Design Chainage in Km	Existing Chainage in Km	Type of Junction	Category of Road	Leads To		Remarks
					LHS	RHS	
5	18+535	18.525	3-legged	City road	Bakar ram	-	
6	20+180	20.215	3-legged	City road	-	Himayathnagar	VUP
7	25+052	-	4-legged	City road	Surangal	Moinabad	VUP
8	27+310	27.145	3-legged	Village Road	Kanaka mamidi road	-	
9	27+620	27.5	4-legged	Village Road	Kanaka mamidi road	Peddamangalram	
10	28+034	27.89	3-legged	Village Road	Kanaka mamidi road	-	VUP
11	29+030	28.850	3-legged	Village Road		Village Road	
12	30+152	29.98	4-legged	Village Road	Kanaka mamidi road	Appareddyguda	
13	30+849	30.67	3-legged	Village Road	Sanjanpally	-	LVUP
14	31+403	31.225	3-legged	Village Road	-	Appareddyguda	
15	32+203	32.043	3-legged	Village Road	Tollkatta	-	LVUP
16	33+419	33.275	3-legged	Village Road	-	Mudimyal	VUP
17	36+644	36.5	3-legged	Village Road	Palgutta	-	LVUP
18	37+877	37.76	3-legged	Village Road	-	Malkapur	
19	39+185	-	3-legged	Village Road	-	kesharam	
20	41+170	-	4-legged	State Highway	Shabad road	Chevalla	VUP
21	42+186	-	3-legged	Village Road	-	Dharma sagar	
22	46+560	45.665	3-legged	Village Road	-	SJHN college of engineering	
23	46+657	45.775	3-legged	Village Road	Dameriguda	-	VUP
24	49+950	49.1	3-legged	Village Road	Bastepur	-	
25	50+003	49.115	3-legged	Village Road	-	Mirjaguda	LVUP
26	52+220	51.35	3-legged	Village Road	Khanapur	-	



Four laning of NH-163 from Hyderabad (ORR Appa Junction) (Design Km 14.000/Existing Km 14.000) to Manneguda (Design Km 60.405/Existing Km 59.500) (Design Length = 46.405 Km) in the State of Telangana under Bharatmala Pariyojna on Hybrid Annuity Mode

Sl. No.	Design Chainage in Km	Existing Chainage in Km	Type of Junction	Category of Road	Leads To		Remarks
					LHS	RHS	
27	52+240	52.335	3-legged	Village Road	Khanapur	-	
28	53+313	53.455	3-legged	Village Road	-	Kisthapur	LVUP
29	55+756	54.900	4-legged	Village Road	Angadichitam pally	Antharam	LVUP
30	57+927	57.095	3-legged	Village Road	Kandlapally	-	LVUP
31	59+771	58.945	3-legged	Village Road	-	Gangupalle	LVUP

Note:

1. Any other junction not mentioned above but observed during the construction of the project shall be improved as per IRC: SP:84-2014 requirements. The same shall not constitute a Change of Scope, save and except any variations arising out of a Change of Scope expressly undertaken in accordance with the provisions of Article 16.
2. The Concessionaire shall take up 'Detailed Engineering study' to ascertain further details of all intersections and treatment of the intersections shall be designed in accordance with the latest guidelines mentioned out in section-3 of IRC:SP:84-2014. The same shall not constitute a Change of Scope, save and except any variations arising out of a Change of Scope expressly undertaken in accordance with the provisions of Article 16.
3. Junction improvement under grade separators shall be carried out as per IRC:SP:84-2014 with proper entry/exit to cross roads and slip/service roads.
4. Location and span arrangement of grade-separated structures are indicative. Exact location may be decided in consultation with Independent Engineer. Any Change in span arrangement shall not be treated as change of scope, save and except any variations in the length arising out of a Change of Scope expressly undertaken in accordance with the provisions of Article 16.

7 Lateral and Vertical Clearances at Underpasses:

Lateral and vertical clearances for VUP / Flyover and provision of guardrails /crash barriers shall be as per paragraph 2.10 of the Manual. The vertical clearance for LVUP shall be 4.0m as against of minimum 3.5m as given in clause 2.10.2 (ii) of the manual. The width of the opening at the underpasses/ flyovers shall be as follows:

Sl. No	Chainage (km)		Total Width (m)	Clear Span/opening (m)	Vertical Clearance (m)	Type of Structure	Remarks
	Existing	Design					
1	20.243	20+180	2 x 11	1 x 25.0	5.5	VUP	Chilkur Balaji Road
2	Moinabad Bypass	22+335	2 x 11	1 x 25.0	5.5	VUP	Start of Bypass, Joginapally Engg. College Road
3	Moinabad Bypass	25+052	2 x 11	1 x 15.0	5.5	VUP	Peddangalaram to Surangal Road
4	Moinabad Bypass	26+084	2 x 11	1 x 25.0	5.5	VUP	End of Moinabad Bypass

Four laning of NH-163 from Hyderabad (ORR Appa Junction) (Design Km 14.000/Existing Km 14.000) to Mannegeuda (Design Km 60.405/Existing Km 59.500) (Design Length = 46.405 Km) in the State of Telangana under Bharatmala Pariyojna on Hybrid Annuity Mode

Sl. No	Chainage (km)		Total Width (m)	Clear Span/opening (m)	Vertical Clearance (m)	Type of Structure	Remarks
	Existing	Design					
5	27.893	28+034	2 x 11	1 x 15.0	5.5	VUP	Appaketiguda&Kanak amamidi Village Road
6	30.683	30+849	2 x 11	1 x 12.0	4.0	LVUP	Kethireedy Pally Village Road
7	32.043	32+203	2 x 11	1 x 12.0	4.0	LVUP	Tolakatta Road
8	33.275	33+419	2 x 11	1 x 15.0	5.5	VUP	Yunis Sultan Engineering College, Mudimyal Road
9	36.504	36+644	2 x 11	1 x 12.0	4.0	LVUP	Palgutta Road
10	Chevella Bypass	39+154	2 x 11	1 x 25.0	5.5	VUP	Start of Chevella Bypass
11	Chevella Bypass	41+170	2 x 11	1 x 25.0	5.5	VUP	Shabad Road Connecting to NH -7 at Farookh Nagar
12	Chevella Bypass	44+511	2 x 11	1 x 25.0	5.5	VUP	End of Chevella Bypass
13	45.775	46+657	2 x 11	1 x 15.0	5.5	VUP	Alhabeed College and Dameriguda
14	49.150	50+003	2 x 11	1 x 12.0	4.0	LVUP	Bastepur - Mirjaguda Road
15	52.465	53+313	2 x 11	1 x 12.0	4.0	LVUP	Angadi - Antharam Road
16	54.925	55+756	2 x 11	1 x 12.0	4.0	LVUP	Allur Road
17	57.097	57+927	2 x 11	1 x 12.0	4.0	LVUP	-
18	58.946	59+771	2 x 11	1 x 12.0	4.0	LVUP	Gangupalle Road

Note:

1. Junction improvement shall be carried out as per IRC Manual and MORTH Templates under grade separators with proper entry/exit to cross roads and slip/service roads.
2. Location and span are indicative. Exact location may be decided in consultation with IE. Any Change in span arrangement shall not be treated as change of scope.
3. At all LVUPs, lateral clearance shall include 2.5m wide raised sidewalk with railing for use of pedestrians.
4. Any additional Barrel length required as per site condition shall not be treated as change in scope of work.

8 Lateral and Vertical Clearances at Overpass:

Lateral and vertical clearances at over passes shall be as per paragraph 2.11 of the Manual. The width of the opening at the over passes shall be as follows:

Sl. No.	Existing Chainage (km)	Design Chainage (km)	Total Width (m)	Clear Span/opening (m)	Vertical Clearance (m)	Type of Structure	Remarks
---------	------------------------	----------------------	-----------------	------------------------	------------------------	-------------------	---------



Four laning of NH-163 from Hyderabad (ORR Appa Junction) (Design Km 14.000/Existing Km 14.000) to Manneguda (Design Km 60.405/Existing Km 59.500) (Design Length = 46.405 Km) in the State of Telangana under Bharatmala Pariyojna on Hybrid Annuity Mode

-NIL-

9 Elevated Corridor:

Sl. No.	Existing Chainage (km)	Design Chainage (km)	Total Width (m)	Clear Span/opening (m)	Vertical Clearance (m)	Type of Structure	Remarks
-NIL-							

10 Slip Roads/ Service Roads

(a) Slip roads shall be constructed at the locations and for the lengths indicated below:

Sl. No.	Design Chainage in Km		Length (m)		Width (m)	Side
	From	To	LHS	RHS		
1	19+450	19+600	150	150	5.5	Both
2	19+600	20+145	545	545	5.5	Both
3	20+170	20+500	330	330	5.5	Both
4	21+770	22+320	550	550	5.5	Both
5	22+345	22+670	325	325	5.5	Both
6	24+400	25+044	644	644	5.5	Both
7	25+059	26+070	1011	1011	5.5	Both
8	26+095	26+420	325	325	5.5	Both
9	27+580	28+018	438	438	5.5	Both
10	28+033	28+380	347	347	5.5	Both
11	30+330	30+824	494	494	5.5	Both
12	30+836	31+230	394	394	5.5	Both
13	31+230	31+600	370	370	5.5	Both
14	31+600	32+186	586	586	5.5	Both
15	32+198	32+800	602	602	5.5	Both
16	32+800	33+393	593	593	5.5	Both
17	33+408	34+150	742	742	5.5	Both
18	36+100	36+614	514	514	5.5	Both
19	36+626	37+100	474	474	5.5	Both
20	38+200	39+120	920	920	5.5	Both
21	39+145	39+700	555	555	5.5	Both
22	40+670	41+120	450	450	5.5	Both
23	41+145	41+800	655	655	5.5	Both
24	42+905	44+480	1575	1575	5.5	Both
25	44+505	45+050	545	545	5.5	Both
26	45+620	46+630	1010	1010	5.5	Both
27	46+645	47+300	655	655	5.5	Both
28	49+550	49+963	413	413	5.5	Both
29	49+975	50+350	375	375	5.5	Both
30	52+250	52+650	400	400	5.5	Both



Four laning of NH-163 from Hyderabad (ORR Appa Junction) (Design Km 14.000/Existing Km 14.000) to Manneguda (Design Km 60.405/Existing Km 59.500) (Design Length = 46.405 Km) in the State of Telangana under Bharatmala Pariyojna on Hybrid Annuity Mode

Sl. No.	Design Chainage in Km		Length (m)		Width (m)	Side
	From	To	LHS	RHS		
31	52+650	53+292	642	642	5.5	Both
32	53+304	53+600	296	296	5.5	Both
33	55+180	55+733	553	553	5.5	Both
34	55+745	56+130	385	385	5.5	Both
35	57+350	57+908	558	558	5.5	Both
36	57+920	58+290	370	370	5.5	Both
37	59+400	59+749	349	349	5.5	Both
38	59+761	60+100	339	339	5.5	Both

Total Length of the Slip Road is 40.958 KM

(b) Service road: Service road shall be constructed at the locations and for the lengths indicated below:

Sl. No.	Design Chainage in Km		Length (m)		Width (m)	Side
	From	To	LHS	RHS		
-NIL-						

Total Length of the Service Road is 0 KM

Note:

1. Above length of the service/slip/connecting roads is indicative and minimum specified. The actual length of the service/slip/connecting roads shall be determined by the Concessionaire in accordance with the approved plan & profile and design approved from the Independent Engineer. Any increase in the length specified in this Clause of Schedule-B shall not constitute a Change of Scope, save and except any variations in the length arising out of a Change of Scope expressly undertaken in accordance with the provisions of Article 16.
2. The realignment of existing track to the VUP/LVUP/SVUP outside the PROW and connecting roads between consecutive underpasses wherever required as per plan & profile uploaded with bid document and specified in Annex III of schedule A is to be constructed by the Concessionaire as per site requirement in consultation with Independent Engineer and the same would not constitute any change of scope.
3. Length of service/slip/connecting roads given in above table excludes length across the Project Highway for proper connectivity of cross roads on either side of project highway which shall be deemed to be included in the scope of work.
4. The Acceleration lane, deceleration lane and transition lane shall be constructed in addition to length given in above table.
5. Entry/Exit Ramp shall also be constructed at all Grade Separated structures as well as Start & End of Service Road at all locations so as to give access of Slip/Service Road to Main Carriageway.
6. Retaining wall shall be provided as per actual site condition to accommodate the Typical Cross Section within available ROW & same shall be deemed to be included in the scope of work.

11 Design of Structures

11.1 General



Four laning of NH-163 from Hyderabad (ORR Appa Junction) (Design Km 14.000/Existing Km 14.000) to Manneguda (Design Km 60.405/Existing Km 59.500) (Design Length = 46.405 Km) in the State of Telangana under Bharatmala Pariyojna on Hybrid Annuity Mode

11.1.1 Project Highway is proposed to be constructed to four-lane configuration. Special vehicle loading is to be considered in design of super-structure of all bridges, culverts and structures.

11.1.2 All bridges, culverts and structures shall be designed and construction for IRC class Special vehicle (SV) loading as per IRC: 6 – 2017 in accordance with section-7 of the IRC: SP:84-2014 and shall conform to the cross-sectional features and other details specified therein.

11.2 Culverts to be reconstructed / widened / new construction

The culverts requiring reconstruction / widening / new construction are given below:

A. Widening of Existing Box/Slab Culverts:

Sl. No.	Existing Chainage (km)	Design Chainage (km)	Type of Flow	Type of Culvert		Span Arrangement	
				Existing	Proposed	Existing	Proposed
-NIL-							

B. Widening of Existing Hume Pipe Culverts (HPC):

Sl. No.	Existing Chainage (km)	Design Chainage (km)	Type of Flow	Type of Culvert		Span Arrangement	
				Existing	Proposed	Existing	Proposed
-NIL-							

C. Reconstruction of Existing Box/Slab Culverts to Box Culverts:

Sl. No.	Existing Chainage (km)	Design Chainage (km)	Type of Crossing	Total Length(m)
1	28.990	29+144	Nala	2.0
2	29.600	29+797	Nala	3.0
3	36.100	36+233	Nala	2.0
4	48.700	49+663	Nala	4.50
5	48.900	49+788	Nala	2.0
6	55.550	56+446	Nala	3.0
7	56.440	57+337	Nala	3.0
8	58.990	59+863	Nala	3.0

Note: The overall width of the above culvert shall be equal to Roadway width of approaches. In other words, the above culverts shall also be provided in median gap and also in gap between main carriageway & service road, in case there is any service road.

D. Reconstruction of Existing Pipe Culverts to Box Culverts:

Sl. No.	Existing Chainage (km)	Design Chainage (km)	Type of Crossing	Total Length
1	17.500	17+553	Nala	2.0
2	19.300	19+328	Nala	4.0
3	21.300	21+320	Nala	2.0
4	27.890	28+070	Nala	4.0
5	31.500	31+731	Nala	2.0
6	38.300	38+431	Nala	2.0

Four laning of NH-163 from Hyderabad (ORR Appa Junction) (Design Km 14.000/Existing Km 14.000) to Manneguda (Design Km 60.405/Existing Km 59.500) (Design Length = 46.405 Km) in the State of Telangana under Bharatmala Pariyojna on Hybrid Annuity Mode

Sl. No.	Existing Chainage (km)	Design Chainage (km)	Type of Crossing	Total Length
7	46.700	47+698	Nala	4.0
8	47.390	48+335	Nala	4.0
9	50.358	51+222	Nala	4.0
10	53.050	53+923	Nala	4.0
11	56.850	57+719	Nala	4.0
12	57.250	58+111	Nala	2.0
13	59.300	60+162	Nala	4.0

E. Reconstruction of Pipe Culvert

Sl. No.	Existing Chainage (km)	Design Chainage (km)	Type of Crossing	Total Length
-NIL-				

F. New Construction of Box / Slab Culverts:

Sl. No.	Design Chainage (km)	Type of Flow	Total Length (m)
1	19+749	Nala	2.0
2	19+976	Nala	3.0
3	22+389	Nala	2.0
4	22+889	Nala	3.0
5	23+068	Nala	2.0
6	23+169	Nala	3.0
7	23+689	Nala	2.0
8	23+932	Nala	3.0
9	24+150	Nala	2.0
10	24+701	Nala	2.0
11	25+454	Nala	2.0
12	25+528	Nala	2.0
13	24+815	Nala	2.0
14	27+488	Nala	2.0
15	28+334	Nala	2.0
16	28+784	Nala	2.0
17	28+948	Nala	2.0
18	32+434	Nala	2.0
19	32+534	Nala	2.0
20	33+944	Nala	2.0
21	34+435	Nala	2.0
22	34+473	Nala	2.0
23	34+979	Nala	2.0
24	37+549	Nala	2.0
25	39+643	Nala	2.0
26	39+744	Nala	2.0
27	39+864	Nala	2.0
28	40+134	Nala	2.0



Four laning of NH-163 from Hyderabad (ORR Appa Junction) (Design Km 14.000/Existing Km 14.000) to Manneguda (Design Km 60.405/Existing Km 59.500) (Design Length = 46.405 Km) in the State of Telangana under Bharatmala Pariyojna on Hybrid Annuity Mode

Sl. No.	Design Chainage (km)	Type of Flow	Total Length (m)
29	40+364	Nala	2.0
30	40+554	Nala	2.0
31	41+498	Nala	2.0
32	41+964	Nala	2.0
33	42+084	Nala	2.0
34	42+221	Nala	2.0
35	42+668	Nala	2.0
36	42+866	Nala	3.0
37	43+004	Nala	2.0
38	43+359	Nala	2.0
39	43+621	Nala	2.0
40	43+992	Nala	2.0
41	45+092	Nala	2.0
42	45+504	Nala	2.0
43	45+711	Nala	2.0
44	45+942	Nala	2.0
45	46+312	Nala	2.0
46	46+410	Nala	2.0
47	46+427	Nala	2.0
48	47+538	Nala	2.0
49	47+862	Nala	2.0
50	47+922	Nala	2.0
51	48+422	Nala	2.0
52	49+212	Nala	2.0
53	53+657	Nala	2.0
54	53+735	Nala	2.0
55	54+968	Nala	2.0
56	55+387	Nala	2.0

G. New Hume Pipe Culverts:

Sl. No.	Design Chainage (km)	Type of Flow	Total Length (m)
-NIL-			

H. New Pipe culverts proposed at Major junctions:

Sl. No.	Design Chainage (km)	Total Length of Culvert (m)	Type of Junction	No of Vents
1	22+335	1.2	3-legged	1
2	26+084	1.2	3-legged	1

Four laning of NH-163 from Hyderabad (ORR Appa Junction) (Design Km 14.000/Existing Km 14.000) to Manneveda (Design Km 60.405/Existing Km 59.500) (Design Length = 46.405 Km) in the State of Telangana under Bharatmala Pariyojna on Hybrid Annuity Mode

Sl. No.	Design Chainage (km)	Total Length of Culvert (m)	Type of Junction	No of Vents
3	39+154	1.2	3-legged	1
4	44+511	1.2	3-legged	1

I. New Hume Pipe culverts at Minor junction:

Sl. No.	Design Chainage (km)	Total Length of Culvert (m)	Type of Junction	No of Vents
1	14+210	1.2	3-legged	1
2	14.580	1.2	3-legged	1
3	15+200	1.2	3-legged	1
4	17+280	1.2	3-legged	1
5	18+535	1.2	3-legged	1
6	20+180	1.2	3-legged	1
7	25+052	1.2	4-legged	2
8	27+310	1.2	3-legged	1
9	27+620	1.2	4-legged	2
10	28+034	1.2	3-legged	1
11	29+030	1.2	3-legged	1
12	30+152	1.2	4-legged	2
13	30+849	1.2	3-legged	1
14	31+403	1.2	3-legged	1
15	32+203	1.2	3-legged	1
16	33+419	1.2	3-legged	1
17	36+644	1.2	3-legged	1
18	37+877	1.2	3-legged	1
19	39+185	1.2	3-legged	1
20	41+170	1.2	4-legged	2
21	42+186	1.2	3-legged	1
22	46+560	1.2	3-legged	1
23	46+657	1.2	3-legged	1
24	49+950	1.2	3-legged	1
25	50+003	1.2	3-legged	1
26	52+220	1.2	3-legged	1
27	52+240	1.2	3-legged	1
28	53+313	1.2	3-legged	1
29	55+756	1.2	4-legged	2
30	57+927	1.2	3-legged	1
31	59+771	1.2	3-legged	1

New Box culverts at Junction Improvement

Sl.No.	Chainage (km)	Total Length (m)
	-Nil	



Four laning of NH-163 from Hyderabad (ORR Appa Junction) (Design Km 14.000/Existing Km 14.000) to Manneguda (Design Km 60.405/Existing Km 59.500) (Design Length = 46.405 Km) in the State of Telangana under Bharatmala Pariyojna on Hybrid Annuity Mode

- In addition to above, additional box culverts of size 3m x 2.5m shall be provided as per site requirements for facilitating access of farmers to field channels on either side of the carriageway and shall be part of scope. The location of such culverts shall be finalized in consultation with Independent Engineer/Project Director, NHA.
- Drains for field channel as per site condition and modification to the irrigation requirement shall be part of scope.

Note:

1. The overall width of the above culverts shall be equal to Roadway width including median & slip roads/ramps, in case there is any slip roads/ramps. Any additional Barrel length required as per site conditions shall not constitute a Change of Scope.
2. Locations of the above culverts are indicative and span arrangement is minimum specified. Exact location of these culverts shall be decided in consultation with Independent Engineer. The actual ventway/span arrangements of culverts shall be determined on the basis of detailed investigations by the Concessionaire in accordance with the Specifications and Standards. Any variations in ventway/span arrangements specified in this Schedule-B shall not constitute a Change of Scope, save and except any variations in the length arising out of a Change of Scope expressly undertaken in accordance with the provisions of Article 16.



Four laning of NH-163 from Hyderabad (ORR Appa Junction) (Design Km 14.000/Existing Km 14.000) to Manneguda (Design Km 60.405/Existing Km 59.500) (Design Length = 46.405 Km) in the State of Telangana under Bharatmala Pariyojna on Hybrid Annuity Mode

12 Details of Bridges to be Reconstructed / Widened / New Construction

All bridges, culverts and structures shall be designed and constructed for IRC class special vehicle (SV) loading as per IRC:6: 2014 and in accordance with section-7 of the IRC:SP:84-2014 and shall conform to the cross-sectional features and other details specified therein. Details of Major Bridges and Minor Bridges to be reconstructed / widened / new construction are given below:

A. Rehabilitation & Repair of Existing Major Bridges and Construction of New Major Bridges:

The following existing major bridges shall be retained and widened to 3-lane standards (existing 2 Lane + New 2 Lane) to be utilized as a bridge for main carriageway on one side and retained bridge shall be repaired /strengthened as per the details given below. New three lane major bridges for main carriageway on other side shall be constructed as per the details given below:

Sl. No.	Chainage (km)		Type of Crossing	Existing Structure Details (m)		Proposal	Proposed Bridge		Nature of Extent of Repairs/ Strengthening to be carried out for existing bridge
	Existing	Design		Existing Span Arrangement	Carriageway Width/Deck Width		Total Length (m)	Width (m)	
-NIL-									

B. Rehabilitation & Repair of Existing Minor Bridges and Construction of new Minor Bridges:

The following existing minor bridge, proposed to be retained and utilized as a bridge for main carriageway on one side, shall be repaired /strengthened as per the details given below. New three Lane minor bridge for main carriageway on other side shall be constructed as per the details given below:

Sl. No.	Chainage (Km)		Type of Crossing	Existing Structure Details		Proposal	Proposed New Bridge			Nature of Extent of Repairs / Strengthening to be carried out for existing bridge
	Existing	Design		Span Arrangement (m)	Carriageway Width/Deck Width (m)		Total Length	Proposed Width (m)		
								Main Carriageway	Service/ Slip Road	
-NIL-										



Four laning of NH-163 from Hyderabad (ORR Appa Junction) (Design Km 14.000/Existing Km 14.000) to Manneguda (Design Km 60.405/Existing Km 59.500) (Design Length = 46.405 Km) in the State of Telangana under Bharatmala Pariyojna on Hybrid Annuity Mode

C. Widening, Rehabilitation & Repair of Existing Minor Bridges and Construction of new Minor Bridges:

The following existing narrow minor bridges, proposed to be widened and utilized as a bridge for main carriageway on one side, shall be repaired /strengthened as per the details given below. New three Lane minor bridges for main carriageway on other side shall be constructed as per the details given below. Also, service road bridge on both sides shall be constructed as per the details given below:

Sl. No.	Chainage (Km)		Type of Crossing	Existing Structure Details		Proposal	Proposed New Bridge			Nature of Extent of Repairs / Strengthening to be carried out for existing bridge
	Existing	Design		Span Arrangement (m)	Carriageway Width/Deck Width (m)		Total Length (m)	Proposed Width (m)		
								Main Carriageway	Service/ Slip Road	
-NIL-										

Note:

- (i) Width is excluding median gap between Main Carriageway & Service Road.
- (ii) The Concessionaire shall be allowed by concerned irrigation department for the construction of above bridges during the canal closing period of 3(Three) months in a year. Change of scope/No claim shall be allowed in this aspect.
- (iii) The Concessionaire shall finalize the span arrangement, design of bridges in consultation with concerned irrigation department, GoTS and IE/Project Director, NHAI.



Four laning of NH-163 from Hyderabad (ORR Appa Junction) (Design Km 14.000/Existing Km 14.000) to Manneguda (Design Km 60.405/Existing Km 59.500) (Design Length = 46.405 Km) in the State of Telangana under Bharatmala Pariyojna on Hybrid Annuity Mode

A. Reconstruction & New Construction of Major Bridges:

The existing bridge at the following location shall be re-constructed as new Structures:

Sl. No.	Chainage (km)		Type of Crossing	Proposal	Total Length (m)	Proposed Width (m)	
	Existing	Design				Main Carriageway	Service/ Slip Road
-NIL-							

B. Reconstruction & New Construction of Minor Bridges:

The existing bridge at the following location shall be re-constructed as new Structures:

Sl. No.	Chainage (Km)		Type of Crossing	Proposal	Total Length (m)	Proposed Width (m)		Remarks
	Existing	Design				Main Carriageway	Service/ Slip Road	
-NIL-								

Note:

- (i) Width is excluding median gap between Main Carriageway & Service Road.
- (ii) The Concessionaire shall be allowed by concerned irrigation department for the construction of above bridges during the canal closing period of 3(Three) months in a year. Change of scope/No claim shall be allowed in this aspect.
- (iii) The Concessionaire shall finalize the span arrangement, design of bridges in consultation with concerned irrigation department, GoTS and Independent Engineer/Project Director, NHAI.

C. New major bridges

New major bridges at the following locations on the Project Highway shall be constructed.

Sl. No.	Design Chainage (Km)	Type of Crossing	Total Length (m)	Proposed Width (m)		Remarks
				Main Carriageway	Service/ Slip Road	
-NIL-						



Four laning of NH-163 from Hyderabad (ORR Appa Junction) (Design Km 14.000/Existing Km 14.000) to Manneguda (Design Km 60.405/Existing Km 59.500) (Design Length = 46.405 Km) in the State of Telangana under Bharatmala Pariyojna on Hybrid Annuity Mode

D. New minor bridges:

New minor bridges at the following locations on the Project Highway shall be constructed.

Sl. No.	Design Chainage (Km)	Type of Crossing	Total Length (m)	Proposed Width (m)		TCS as per Manual
				Main Carriageway	Service/ Slip Road	
1	42.341	Nala	40.0	2 x 12.5	-	7.2 A
2	42.921	Nala	10.0	2 X 12.5	2X10.8	7.2 B

Note:

- Width is excluding median gap between Main Carriageway & Service Road.
- The Concessionaire shall finalize the span arrangement, design of bridges in consultation with concerned irrigation department, GoTS and IE/Project Director, NHA.
- The change in length or span arrangement shall not be treated as change of scope.

13 Interchange

Sl. No.	Name of the Structure	Length (m)	Typical Cross Section	Proposed Improvement	Remarks
-Nil-					

14 Retaining wall

Retaining wall shall be provided for the chainages mentioned below:

a. LHS Side

Sl. No.	Design Chainage		Length (m)	Side
	From (km)	To (Km)		
-Nil-				

b. RHS Side:

Sl. No.	Design Chainage		Length (m)	Side
	From (km)	To (Km)		
-Nil-				

Note: Above Length and height of Retaining wall is tentative and minimum specified. The actual length of Retaining wall and Toe wall shall be determined by the Concessionaire in accordance with the IRC:SP:84-2014 requirements with approval from the Independent Engineer. Any increase in the length and height specified in this Clause of Schedule-B shall not constitute a Change of Scope. Any variations in the length arising out of a Change of Scope expressly undertaken in accordance with the provisions of Article 16.

15 Road Over Bridge (ROB)

Chainage (Km)	Proposal	Proposed Structure Details
---------------	----------	----------------------------



Four laning of NH-163 from Hyderabad (ORR Appa Junction) (Design Km 14.000/Existing Km 14.000) to Manneguda (Design Km 60.405/Existing Km 59.500) (Design Length = 46.405 Km) in the State of Telangana under Bharatmala Pariyojna on Hybrid Annuity Mode

Sl. No.	Existing	Design	Type of Crossing	Existing Span Arrangement		Span Arrangement (m)	Width
-Nil-							

16 Right of Way

The details of ROW are given in Annexure – II of Schedule A.

17 Utilities

Provision for accommodating utilities shall be made both overhead as well as underground wherever required as per IRC 98.

18 COMPULSORY AFFORESTATION

Minimum 14410 Nos. of trees are required to be planted by the Concessionaire as compensatory afforestation in accordance with IRC: SP : 84-2014, keeping in view IRC: SP:21-2009. Any increase in No. of trees shall not be treated as change of scope, save and except any variations arising out of a Change of Scope expressly undertaken in accordance with the provisions of Article 16.

19 Hazardous Locations :The safety barriers shall also be provided at the following hazardous locations:

Sr. No.	Location stretch from (km) to (km)	LHS/RHS
1.	Metal Beam Crash Barrier (W shaped) single phase shall be provided by the contractor, where embankment height is more than 3m, curves having radius up to 450m, Metal Beam Crash Barrier shall also be provided on approaches to bridges on either side in continuation of RCC Crash barriers as per IRC SP 2019.	
2.	RCC Crash barrier shall be provided over bridges, VUP, LVUP, ROB & over Reinforced earth walls and RCC Retaining walls of full height of embankment and at other location as per Manual and consultation with Independent Engineer.	
3.	Pedestrian Guard rail and safety barrier shall be provided by the contractor at the location determine by the Independent Engineer and the NHAI as per the provision of the Manual.	
4.	The Location of median barrier and concrete barrier as per section 9 of the Manual shall be determined and provide by the contractor in consultation with the Independent Engineer and NHAI.	

20 Rain Water Harvesting Structure

As per Ministry of Environment and Forests Notification, New Delhi dated 14.01.1997 (as amended on 13.01.1998, 05.01.1999 & 6.11.2000) and MORTH Circular No RW/NH-33044/14/2003-S&R(R) dated 03.09.2021, the construction of Rain water, harvesting structure is mandatory in and around Water Crisis area, notified by the Central Ground Water Board. The provision of rain water harvesting shall be provided at every 500m in the entire project length and shall be executed as per requirement of IRC SP: 42-2014 and IRC SP: 50-2013.



Four laning of NH-163 from Hyderabad (ORR Appa Junction) (Design Km 14.000/Existing Km 14.000) to Manneguda (Design Km 60.405/Existing Km 59.500) (Design Length = 46.405 Km) in the State of Telangana under Bharatmala Pariyojna on Hybrid Annuity Mode

21 Change of Scope

The length of Structures and bridges specified herein above shall be treated as an approximate assessment. The actual lengths as required on the basis of detailed investigations shall be determined by the Concessionaire in accordance with the Specifications and Standards. Any variations in the lengths specified in this Schedule-B shall not constitute a Change of Scope, save and except any variations in the length arising out of a Change of Scope expressly undertaken in accordance with the provisions of Article 16.



Four laning of NH-163 from Hyderabad (ORR Appa Junction) (Design Km 14.000/Existing Km 14.000) to Manneguda (Design Km 60.405/Existing Km 59.500) (Design Length = 46.405 Km) in the State of Telangana under Bharatmala Pariyojna on Hybrid Annuity Mode

Annex-I of Schedule 'B'

22 Shifting of Utilities

Shifting of obstructing utilities to an appropriate location in accordance with the standards and specifications of concern Utility Departments is a part of scope of work for the Concessionaire. The bidder may visit the site and assess the quantum of shifting of utilities for the project before submission of their bid. The specifications are to be as per the specification of concerned utility owning department.

The utilities detailed as per Schedule-A are to be shifted/realigned at the extreme edge of defined ROW in close coordination with utility owning department as per following guidelines:-

- (a) The type/spacing/size/specifications of poles/towers/lines/cables to be used in shifting work are as per the guidelines of utility owning department and it is solely between the Concessionaire and the utility owning department. No change of scope shall be eligible or no cost shall be paid for using different type/spacing /size/specifications in shifted work in comparison to those in the existing or for making any overhead crossings to underground as per requirement of utility owning department/construction of project highway. The Concessionaire shall carry out joint inspection with utility owning department and get the estimates sanctioned from utility owning department. The assistance of the Authority is limited to giving forwarding letter on the proposal of Concessionaire to utility owning department whenever asked by the Concessionaire. The decision/approval of utility owning department shall be binding on the Concessionaire. No CoS or no cost shall be eligible on any account.
- (b) The supervision charges at the rates/charges applicable between implementing agencies of MoRTH and utility owning department shall be paid directly by the Authority to the Utility Owning Entity as and when Concessionaire furnishing a demand of Utility Owning Department along with a copy of sanctioned estimate.
- (c) The credit of dismantled materials has been accounted for in the estimated cost. The dismantled material /scrap of existing Utility to be shifted/dismantled shall belong to the Contractor/Concessionaire who would be free to dispose-off the dismantled material as deemed fit by them. If the Concessionaire is forced to deposit the dismantled material to utility owning department then the amount of credit for dismantled material indicated in the sanctioned estimates of utility owning department will be reimbursed to the Concessionaire after submitting the duly authenticated receipt of the dismantled material from utility owning department to the Authority.
- (d) The utilities shall be handed over after shifting work is completed to Utility Owning Department up to their entire satisfaction. The maintenance liability shall rest with the Utility Owning Department after handing over process is complete as far as utility shifting works are concerned.

Note:- It is obligation of successful bidder to keep all public utilities functional all time without any cost to Authority beyond quoted amount.



Four laning of NH-163 from Hyderabad (ORR Appa Junction) (Design Km 14.000/Existing Km 14.000) to Manneguda (Design Km 60.405/Existing Km 59.500) (Design Length = 46.405 Km) in the State of Telangana under Bharatmala Pariyojna on Hybrid Annuity Mode

23 Use of Fly ash:

As regards the supply of fly-ash, the spirit of Ministry of Power OM dated 22.09.2021(Copy Encl.) shall be following.





No. 9/7/2011-S.Th.(Vol. IV)
Government of India
Ministry of Power

'F' Wing, Nirman Bhawan,
New Delhi, 22nd September, 2021

To,

1. CMDs/ MDs of coal / lignite based thermal power plants (Central/ State/ Private)
2. Principal Secretary (Power/ Energy) of All States/ UT's
3. Chairperson, Central Electricity Authority

Subject: Supply of Fly ash to the end users by the power plants to increase fly ash utilization

It is observed that the demand of Fly Ash has been increasing year on year basis contributing to increase in the Fly Ash utilization. Fly Ash is emerging as a valuable commodity. As the end users of Fly Ash like cement plants, brick kilns, road and construction agencies etc. are commercial ventures and all their input costs are accounted for, Fly Ash should invariably be auctioned through a transparent bidding process.

2. All Coal/lignite based power plants are hereby advised to provide fly ash to the end users for all new commitments for supply of fly ash based on the following guidelines:

2.1 The power plants shall provide the Fly Ash to end users through a transparent bidding process only.

2.2 If after bidding/ auction some quantity of Fly Ash still remains un-utilized, then only, as one of the options, it could be considered to be given free of cost on first come first served basis if the user agency is willing to bear transportation cost.

2.3 If ash remains unutilised even after the steps taken in Paras 2.1 and 2.2 above, TPP shall bear the cost of transportation of Fly Ash to be provided free to eligible projects.

2.4 The end users shall be obligated to source the fly ash from the nearest TPPs to reduce the cost of fly ash transportation. If the nearest TPP refuses to do so, the end user project shall approach Ministry of Power for appropriate directions.

2.5 The transportation cost wherever required to be borne as per provisions of MIOEF&CC notification by the power plants, shall be discovered on competitive bidding basis only. Thermal Power Plants shall prepare a panel of transportation agencies every



year based on competitive bidding for transportation in slabs of 50km which may be used for the period. The TPPs shall call for bids well in advance so, that a transportation panel is in place as soon as the previous panel expires. There should not be gap between the expiry of one panel and the finalization of the fresh panel.

2.6 The fly ash will be offered to the end users on the competing demand basis, i.e the end users who offer the highest price for fly ash and seek minimum support for transportation cost will be offered the same fly ash on priority. This will reduce the tariff of electricity and burden on the consumers.

2.7 The power plants may offer fly ash subject to their technical restrictions such as all precautions required for Dyke Stability and Safety etc. The power plants having lower ash utilizations shall make all out efforts to increase the fly ash utilization.

3. All concerned are requested to take necessary action in this regard.

4. This issues with the approval of the Hon'ble Minister of Power and NRE.

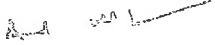
(Anand Upadhyay)
Deputy Secretary to the Govt. of India
Tel: 23062439

Copy to:

- i. Secretary (MOEF&CC), Government of India
- ii. Secretary (MoRTH), Government of India
- iii. Secretary (MoHUA), Government of India
- iv. Secretary, CERC
- v. Secretaries of all SERCs/ JERCS

Copy for kind information to:

PS to MOP, PS to MOSP, Sr. PPS to Secretary (Power), All Joint Secretaries/ EA/ CE (Thermal), Directors/DS, MOP



Four laning of NH-163 from Hyderabad (ORR Appa Junction) (Design Km 14.000/Existing Km 14.000) to Manneguda (Design Km 60.405/Existing Km 59.500) (Design Length = 46.405 Km) in the State of Telangana under Bharatmala Pariyojna on Hybrid Annuity Mode

SCHEDULE– C

(See Clause 2.1)

1 Project Facilities

1.1 The concessionaire shall construct the project facilities in accordance with the provisions of this agreement. Such Project facilities shall include:

- (a) Toll Plazas;
- (b) Roadside Furniture;
- (c) Highway Lighting;
- (d) Pedestrian Facilities;
- (e) Rest areas (Wayside amenities);
- (f) Truck lay-byes;
- (g) Bus-bays and bus shelters;
- (h) Cattle crossings;
- (i) Traffic aid posts;
- (j) Medical aid posts;
- (k) Vehicle rescue posts;
- (l) Highway patrol Unit;
- (m) Emergency Medical Services (Ambulance);
- (n) Crane services;
- (o) Operation & Maintenance Center;
- (p) Landscaping and Tree Plantation;
- (q) Communication system;
- (r) Advanced Traffic Management;
- (s) Environmental Management Plan and
- (t) Facilities to be provided to NHAI:

1.2 Project Facilities as specified in Annex – I of this Schedule – C shall be completed on or before COD.



Four laning of NH-163 from Hyderabad (ORR Appa Junction) (Design Km 14.000/Existing Km 14.000) to Manneguda (Design Km 60.405/Existing Km 59.500) (Design Length = 46.405 Km) in the State of Telangana under Bharatmala Pariyojna on Hybrid Annuity Mode

SCHEDULE – C
(See Clause 2.1)
PROJECT FACILITIES
(Annex-I)

1. Project Facilities

The Concessionaire shall construct the Project Facilities described in this Annex-I to form part of the Four/six – Lane Project. The Project Facilities shall include:

- a) Toll Plazas;
- b) Roadside Furniture;
- c) Highway Lighting;
- d) Pedestrian Facilities;
- e) Rest areas (Wayside amenities);
- f) Truck lay-byes;
- g) Bus-bays and bus shelters;
- h) Cattle crossings;
- i) Traffic aid posts;
- j) Medical aid posts;
- k) Vehicle rescue posts;
- l) Highway patrol Unit;
- m) Emergency Medical Services;
- n) Crane services;
- o) Operation & Maintenance Center;
- p) Landscaping and Tree Plantation;
- q) Communication system;
- r) Advanced Traffic Management;
- s) Environmental Management Plan and

2. Description of Project Facilities

Each of the Project Facilities is described below:

(a) Toll Plaza location:

As stipulated in Manual of Specifications and Standards for Four – Laning of Highways through Public Private Partnership (IRC: SP: 84-2014).

Toll Plazas shall be provided at the following locations:

Sl. No.	Location	Existing Chainage (Km)	Design Chainage (Km)	Number of Toll Lanes	
				Entry	Exit
01	Near Angadichittimpalle	53+600	54+450	8	8



Four laning of NH-163 from Hyderabad (ORR Appa Junction) (Design Km 14.000/Existing Km 14.000) to Manneguda (Design Km 60.405/Existing Km 59.500) (Design Length = 46.405 Km) in the State of Telangana under Bharatmala Pariyojna on Hybrid Annuity Mode

- i. Above mentioned toll lanes are indicative. Concessionaire shall assess actual requirement of toll lanes as per actual site condition and manual. These toll lanes shall be finalized in consultation with Independent Engineer/ Project Director, NHA. The additional toll lanes shall not be treated as change of scope
- ii. Solar panels shall be erected over the Toll Plaza Canopy to generate the green energy. Same shall be utilized for toll plaza lighting with LED lights and other energy requirement within toll plaza area. In addition to solar panels conventional lighting shall be provided by Concessionaire.
- iii. All Toll Lanes to be equipped with ETC/Fastag Facility equipments.
- iv. One Helipad shall be constructed in the Project Corridor. The location shall be finalized in consultation with Independent Engineer/Project Director, NHA.
- v. A separate toilet facilities shall be provided near toll plaza location along with parking facility for road users. One toilet block on each direction shall be provided. These toilets facilities shall follow CPWD specifications for sanitary ware items and fittings such as EWC, Wash Basin, Wash Basin – under counter, Urinal flat back, PVC Cistern, IWC Orissa pan, Flush Valve – CP, Wash basin pillar cock-CP, Bib Cock - CP, Health Faucet, W/C bib Cock and Wash basin angle cock. Drawing of Toilet facility is enclosed at Appendix-I of this Annexure.
- vi. Weigh in Motion (WIM) devices shall be provided in toll lanes at Toll Plaza Location. In addition to WIM, static weigh Bridge (SWBs) shall be provided on each direction as per manual.
- vii. Point of sale (POS) with card swapping machines shall be provided.

(b) Road side furniture: The roadside furniture shall be as per Section 9 of the manual and as per guidelines given in IRC:8, IRC:25, IRC:26, IRC:35, IRC:67, IRC:79, IRC:103 and Section 800 of MoRT&H Specifications and shall include

- i. **Traffic Signs:** Traffic signs shall include roadside signs, overhead signs, kerb mounted signs etc. along the entire project highway. The detailed signage plan indicating places, direction, distances and other features marked on the change plan shall be prepared and same shall be finalized in consultation with Independent Engineer/project Director, NHA as per site requirement.
- ii. **Overhead Traffic Signs:** Excluding overhead signs and other signs at Toll Plaza location which are to be provided as per Manual of Specifications and Standards as referred in Schedule D, the location of these facilities shall be finalized in consultation with Independent Engineer/Project Director, NHA as per site requirement. However minimum 17nos of Gantry Overhead signs and 2nos of Cantilever excluding toll plaza location shall be provided.
- iii. **Pavement Markings:** Shall cover road marking for the entire Project highway including toll plaza.
- iv. **LED Traffic Blinkers:** These shall be provided on the entire Project Highway near pedestrian crossings, public gathering places (Educational Institutions, Hospitals, Worshipping Places, etc.), cross roads, & median openings, structures like VUP/LVUP.
- v. **Crash barrier:** W Metal Beam Crash Barrier shall be provided at built up location, High



Four laning of NH-163 from Hyderabad (ORR Appa Junction) (Design Km 14.000/Existing Km 14.000) to Manneguda (Design Km 60.405/Existing Km 59.500) (Design Length = 46.405 Km) in the State of Telangana under Bharatmala Pariyojna on Hybrid Annuity Mode

Embankment &, Bridge approaches and curve locations where radius is less than 450m. The locations for these provisions shall be as per Section 9.7 of Manual and finalized in consultation with Independent Engineer/Project Director, NHAI.

- vi. **Cat's Eye / Road Studs:** Road Studs shall be provided at Horizontal Curve below 700m, median opening, intersections, Cross roads & Built-up areas (Excluding Toll Plaza location) and shall conform to the specifications mentioned in Schedule D.
- vii. **Delineators/Road Studs:** Shall be provided for Entire Project highway as per IRC:79-2019 and site requirement & specification as per Schedule D.
- viii. Deleted.
- ix. **Hectometer / Kilometer Stones:** Shall be provided for Entire Project highway.
- x. **Boundary Wall & Toe wall:** Toe wall (RCC pre-cast panel) shall be provided along the extreme outer line of ROW as per the cross-section enclosed at Appendix-II of this Annexure, along the complete stretch except bypass locations & cross roads. Boundary wall shall be provided along the extreme outer line of ROW as per the cross-section enclosed at Appendix-III of this Annexure, on the bypass locations.

(C) **Highway Lighting:** Shall be provided in accordance with Section 12 of the Manual.

Highway lighting (LED) of required LUX at reference location shall be provided at the following locations:

- (i) At Toll Plazas, Rest area, Truck Lay bye, Bus bays, bus shelter as given in this schedule – C, Grade separators and its approaches, built up sections & junctions as location given in schedule – B.
- (ii) Solar lighting shall be considered near junctions, and at toll plaza locations. Solar Panels also to be established at any other preferred locations along with Conventional lighting.

Not to be limited to the above specified locations and it shall be finalized in consultation with Independent Engineer / Project Director, NHAI.

(d) **Pedestrian facilities:** Pedestrian Facilities shall be provided in accordance with the Manual of Specifications and Standards as referred in Schedule D.

Pedestrian Facilities include the provision of:

- (i) Pedestrian Guard Rail:

Pedestrian guard rails shall be provided at each bus bay, bus shelter location, built-up sections and intersections as specified in the manual.

- (ii) Pedestrian crossings:



Four laning of NH-163 from Hyderabad (ORR Appa Junction) (Design Km 14.000/Existing Km 14.000) to Manneguda (Design Km 60.405/Existing Km 59.500) (Design Length = 46.405 Km) in the State of Telangana under Bharatmala Pariyojna on Hybrid Annuity Mode

Pedestrian crossing shall be provided on service roads, built-up sections and intersections as specified in the manual

The additional pedestrian facilities in the form of guard rails, footpath, lighting etc. shall be provided wherever required in accordance with Section 12.2 of the IRC Manual Standards and Specifications.

(e) Deleted

(f) Truck lay byes:

The truck lay-bye shall be provided at below given location.

Sl. No.	Existing km	Design Chainage Km	Side	Location Name
1	-	23+250	Both	Moinabad Bypass

Toilet block on each Truck Lay bye shall be provided as per drawing at Appendix –I of Annexure I of Schedule C. These toilets facilities must be functional 24x7 with maintenance facility.

(g) Bus Bays and Passenger shelters:

- i. Locations for Bus Bays are indicated in the table given below. However, the same shall be finalized as per suitability of location and site requirement in consultation with Independent Engineer / Project Director, NHAI.

Sl. No.	Design Chainage (Km)	Facility
1	20+000	Bus bay/ Passenger Shelter on LHS
2	20+300	Bus bay/ Passenger Shelter on RHS
3	41+050	Bus bay/ Passenger Shelter on LHS
4	41+300	Bus bay/ Passenger Shelter on RHS

- ii. Locations for Passenger shelters are indicated in the table given below. However, the same shall be finalized as per suitability of location and site requirement in consultation with Independent Engineer / Project Director, NHAI.

Sl. No.	Design Chainage (Km)	Facility
1	16+000	Passenger Shelter on LHS
2	16+200	Passenger Shelter on RHS
3	17+200	Passenger Shelter on LHS
4	17+400	Passenger Shelter on RHS
5	18+400	Passenger Shelter on LHS
6	18+600	Passenger Shelter on RHS
7	22+200	Passenger Shelter on LHS

Four laning of NH-163 from Hyderabad (ORR Appa Junction) (Design Km 14.000/Existing Km 14.000) to Manneguda (Design Km 60.405/Existing Km 59.500) (Design Length = 46.405 Km) in the State of Telangana under Bharatmala Pariyojna on Hybrid Annuity Mode

Sl. No.	Design Chainage (Km)	Facility
8	22+500	Passenger Shelter on RHS
9	25+950	Passenger Shelter on LHS
10	26+200	Passenger Shelter on RHS
11	27+900	Passenger Shelter on LHS
12	28+200	Passenger Shelter on RHS
13	30+700	Passenger Shelter on LHS
14	32+100	Passenger Shelter on LHS
15	32+300	Passenger Shelter on RHS
16	33+300	Passenger Shelter on LHS
17	33+650	Passenger Shelter on RHS
18	36+500	Passenger Shelter on LHS
19	39+000	Passenger Shelter on LHS
20	39+300	Passenger Shelter on RHS
21	46+500	Passenger Shelter on LHS
22	49+900	Passenger Shelter on LHS
23	50+100	Passenger Shelter on RHS
24	52+300	Passenger Shelter on LHS
25	52+400	Passenger Shelter on RHS
26	53+400	Passenger Shelter on RHS
27	55+900	Passenger Shelter on RHS
28	59+900	Passenger Shelter on RHS

(h) Cattle Crossings: Nil

(i) Traffic Aid Posts

Traffic aid post shall be constructed at the toll plaza in consultation with the Independent Engineer/Project Director, NHAI, not exceeding 25 (twenty five) square meter of plinth area, 2nos of patrolling vehicles to carry out the obligations. Specification and requirements shall be strictly as per concession agreement and schedule "D".

(j) Medical Aid Posts

The Concessionaire shall, at its cost and in accordance with the type designs prescribed for such buildings by the State Medical Department (or a substitute thereof to be designated by the Authority), construct an aid post building at toll plaza location and hand it over to the Authority, no later than 30 (thirty) days prior to COD. The Medical Aid Post(s) shall be deemed to be part of the Site and shall vest in the Authority. Medical Aid Post shall be set up at Administrative Block with 2 nos of Ambulance with round-the-clock services for victims of accidents on the Project Highway. Such Post and two residential quarters shall be constructed in accordance with the type designs prescribed by the State Medical Department and shall be maintained throughout the



Four laning of NH-163 from Hyderabad (ORR Appa Junction) (Design Km 14.000/Existing Km 14.000) to Manneguda (Design Km 60.405/Existing Km 59.500) (Design Length = 46.405 Km) in the State of Telangana under Bharatmala Pariyojna on Hybrid Annuity Mode

contract period. Ambulance shall be provided as per Annexure-I of NHA/policy guidelines/ Incident Management /2021, Policy No.18.66 dated 11th March 2021, along with all necessary manpower (including paramedic staff) and shall be maintained throughout the contract period.

(k) Vehicle Rescue Posts

Vehicle Rescue post shall be constructed at the Toll Plaza in consultation with the Independent Engineer/Project Director, NHA. 2nos of crane services to tow away the disabled vehicles and Specification and requirements shall be strictly as per concession agreement and schedule "D" .

(l) Highway Patrol Unit: Highway Patrol unit shall be provided as specified in the manual.

(m) Emergency Medical Service: Emergency Medical Service shall be provided as specified in the manual.

(n) Crane service: Crane service shall be provided as specified in the Manual.

(o) Operation and Maintenance Centre: Operation and Maintenance Centre shall be provided as specified in the manual.

(p) Landscaping and Tree Plantation:

- (i) Median: The plantation in the median shall be as per provision of IRC SP-21
- (ii) Avenue plantation shall be done in minimum two rows (one row on each side as per IRC SP-84 / IRC SP 21 including Tree Guard with MS angle Iron and Steel Wire.
- (iii) Below the Grade Separated intersections, Entry & Exit Ramps and Islands of At grade intersections; and
- (iv) Toll Plaza Area and O&M Centre Tree Plantation shall be provided in accordance with the Manual of Specifications and Standards as referred in Schedule D and in accordance with National Green Highway Policy 2015.

(q) Communication system: Communication system shall be provided as specified in the Manual.

(r) Advanced Traffic Management System: The Concessionaire is required to design, install, operate and maintain Highway Traffic Management System (HTMS) / Advanced Traffic Management System (ATMS) as part of the project facilities. Advanced Traffic Management System shall be provided as specified the manual.

Briefly, the ATMS components to be deployed shall inter alia include:

- (a) Video Surveillance System (CCTV PTZ Dome / Fixed Camera)
- (b) Video Incident Detection System



Four laning of NH-163 from Hyderabad (ORR Appa Junction) (Design Km 14.000/Existing Km 14.000) to Manneguda (Design Km 60.405/Existing Km 59.500) (Design Length = 46.405 Km) in the State of Telangana under Bharatmala Pariyojna on Hybrid Annuity Mode

- (c) Vehicle Actuated Radar Speed Displays
- (d) Emergency Roadside Telephones
- (e) Fixed / Portable Variable Message Sign
- (f) Meteorological System
- (g) Portable Weigh in Motion
- (h) Automatic Traffic Counter cum Classifier
- (i) The ATMS Control Centre including the equipment (hardware, software, and local networking)
- (j) Communications System utilizing Optic fiber, GSM/GPRS and Wi-Fi Communications linked to ATMS Control Centre.
- (k) Power supplies for field equipment: working on Mains power supported with back-up (largely on renewable energy) to facilitate 24x7 operation and for the ATMS Control Centre working on Mains power supported by UPS and Diesel generator set of adequate capacities, to facilitate 24x7 operation.

(s) **Environmental Management Plan :**

The Concessionaire shall implement the Environmental Management plan & action Plan for undertaking possible mitigation measures in accordance with guidelines for Highway Projects of the Ministry of Environment and Forests and Wild Life Department. The conditions & directions stipulated by the MOEF shall be make available by the Authority.



Four laning of NH-163 from Hyderabad (ORR Appa Junction) (Design Km 14.000/Existing Km 14.000) to Manneguda (Design Km 60.405/Existing Km 59.500) (Design Length = 46.405 Km) in the State of Telangana under Bharatmala Pariyojna on Hybrid Annuity Mode

**Appendix-I of Annex-I
(Schedule-C)**

Standard Drawing for Toilet Block



Four laning of NH-163 from Hyderabad (ORR Appa Junction) (Design Km 14.000/Existing Km 14.000) to Manneguda (Design Km 60.405/Existing Km 59.500) (Design Length = 46.405 Km) in the State of Telangana under Bharatmala Pariyojna on Hybrid Annuity Mode

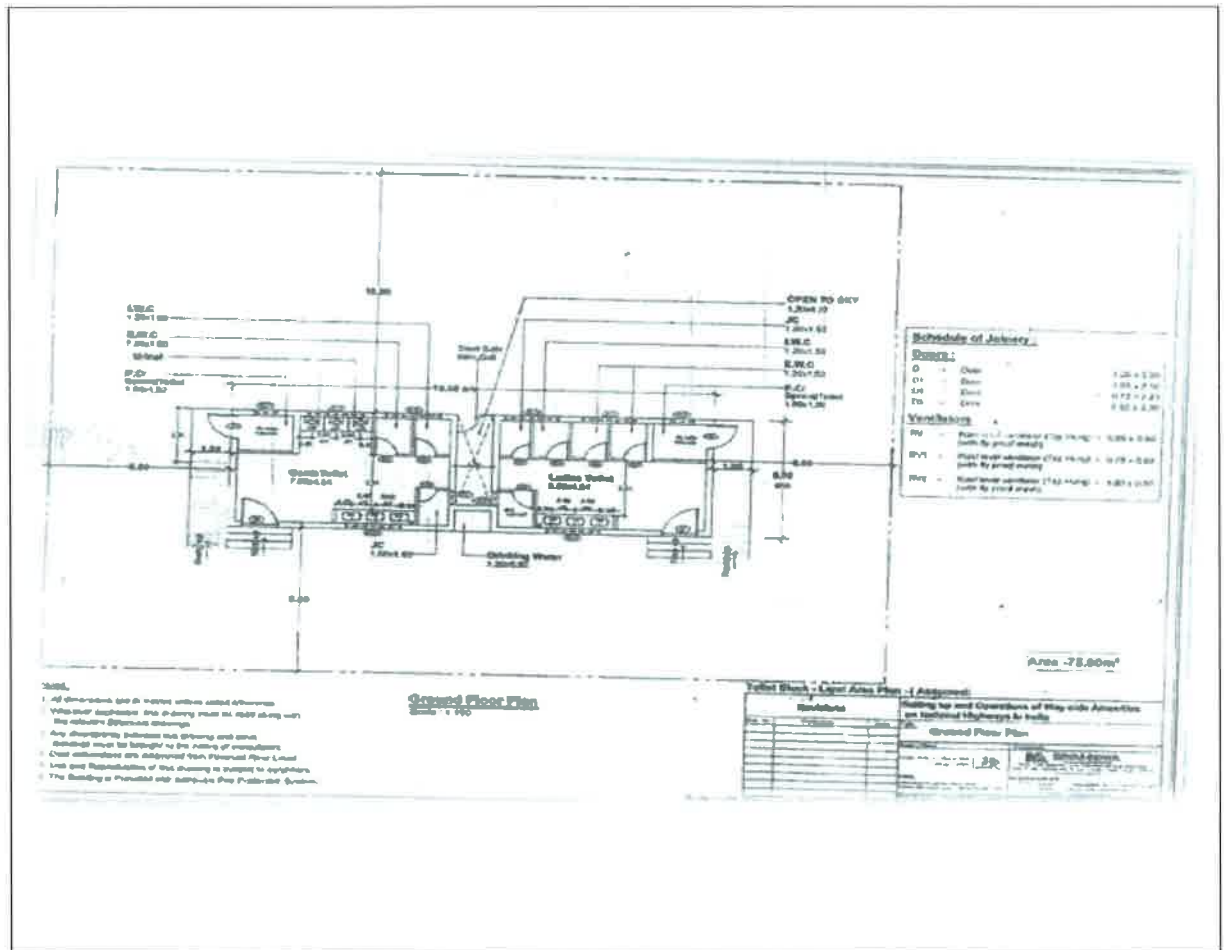

Four laning of NH-163 from Hyderabad (ORR Appa Junction) (Design Km 14.000/Existing Km 14.000) to Manneguda (Design Km 60.405/Existing Km 59.500) (Design Length = 46.405 Km) in the State of Telangana under Bharatmala Pariyojna on Hybrid Annuity Mode

Appendix-II of Annex-I
(Schedule-C)

Standard Drawing for Toe Wall

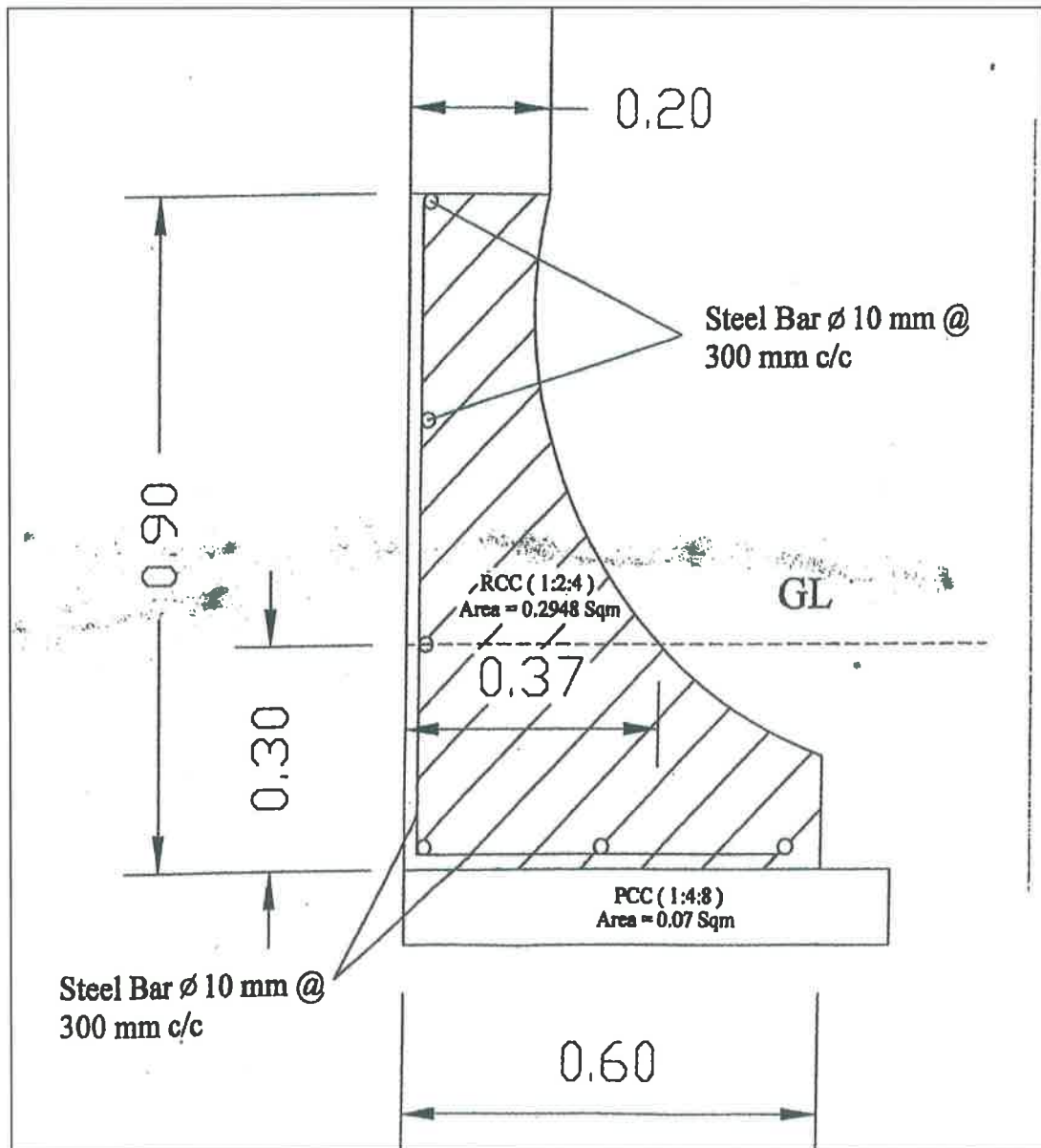

Note: Dimensions are in Metre.

Four laning of NH-163 from Hyderabad (ORR Appa Junction) (Design Km 14.000/Existing Km 14.000) to Manneguda (Design Km 60.405/Existing Km 59.500) (Design Length = 46.405 Km) in the State of Telangana under Bharatmala Pariyojna on Hybrid Annuity Mode

Appendix-III of Annex-I
(Schedule-C)

Standard Drawing for Boundary Wall

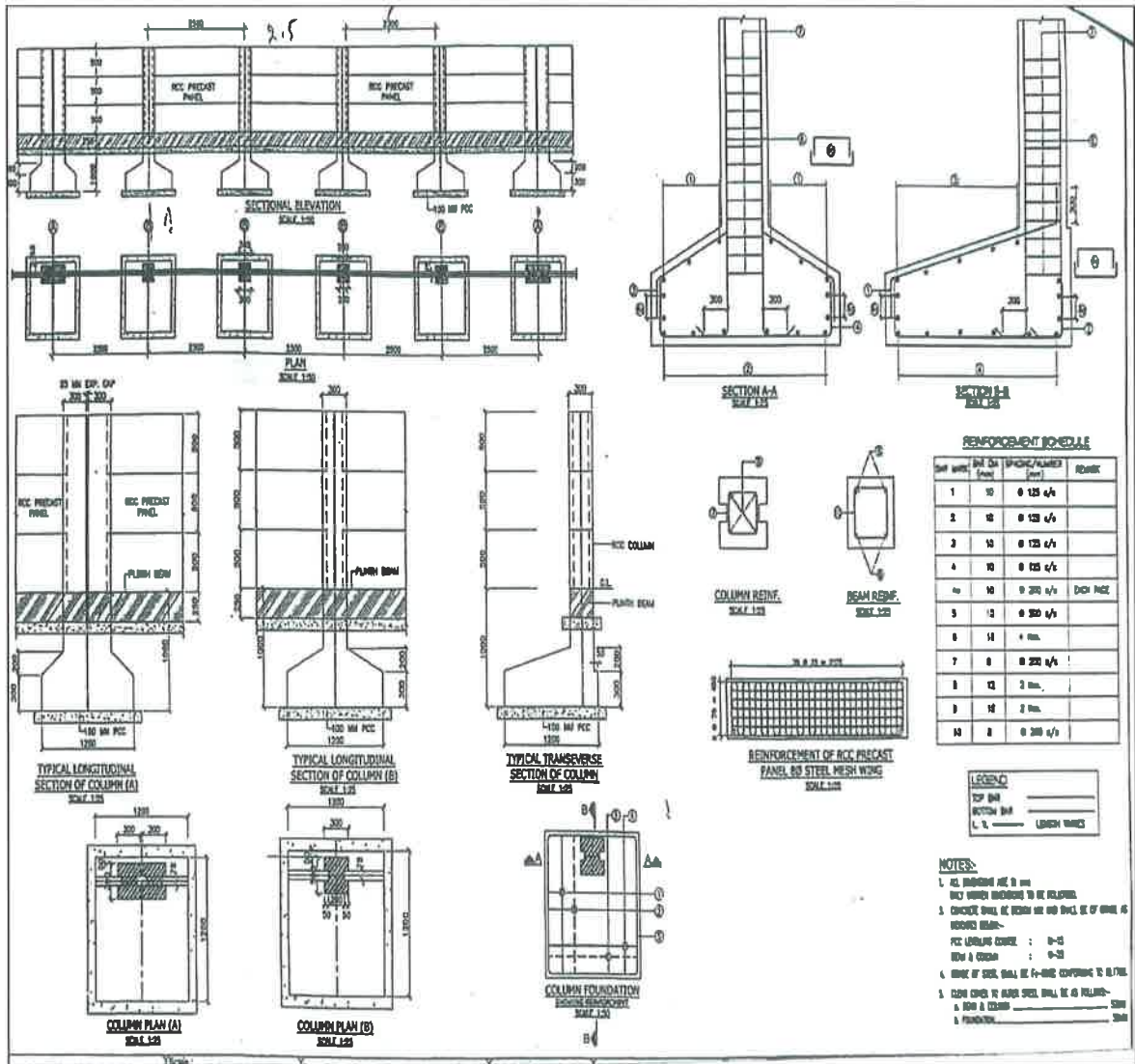

Four laning of NH-163 from Hyderabad (ORR Appa Junction) (Design Km 14.000/Existing Km 14.000) to Manneguda (Design Km 60.405/Existing Km 59.500) (Design Length = 46.405 Km) in the State of Telangana under Bharatmala Pariyojna on Hybrid Annuity Mode

SCHEDULE– D

(See Clause 2.1)

SPECIFICATIONS AND STANDARDS

1 Construction

The Concessionaire shall comply with the Specifications and Standards set forth in Annex-I of this Schedule-D for construction of the Project Highway.

2 Design Standards

The Project Highway including Project Facilities shall conform to design requirements set out in the following documents:

Manual of Specifications & Standards for four laning of Highways through PPP (IRC: SP: 84-2014), referred to herein as the manual.

As regards to work of utility shifting, the relevant specifications, relevant rules, regulations and acts of Utility owning Department/Agencies shall be applicable.



Four laning of NH-163 from Hyderabad (ORR Appa Junction) (Design Km 14.000/Existing Km 14.000) to Manneguda (Design Km 60.405/Existing Km 59.500) (Design Length = 46.405 Km) in the State of Telangana under Bharatmala Pariyojna on Hybrid Annuity Mode

Annex – I
(Schedule-D)
Specifications and Standards for Construction

Specifications and Standards

Four – Laning of the Project shall conform to the Manual of Specifications and Standards for Four – Laning of Highways through Public Private Partnership published by the IRC (IRC: SP: 84-2014, Referred as 4 laning manual).

Deviations from the Manual

Notwithstanding anything to the contrary contained in the aforesaid Manual, the following Specifications and Standards shall apply to the construction of the Project Highway, and for purposes of this agreement, the aforesaid manual shall be deemed to be amended to the extent set forth below:

Sl. No.	Clause No.	Details of Item	Description of Deviation
1	2.3	ROW	The 60m ROW has been proposed except for from D.Ch. km. 14+000 to km. 18+500 (Mrugavani National Park area) and Stretches of D.Ch. 18+500 to 19+300 due to site constraints as mentioned in schedule - A.
2	7.3	Overall width of structures	The Overall Deck Configuration of all structures shall be as per Schedule B.
3	2.17	Typical Cross Section	The typical cross section shall be as given in Schedule B.
4	7.19	Fig: 7.8	For Grade Separated Structures 11.00m deck width is considered instead of 14.5m.
5	5.2	Type of Pavement	The type of pavement shall as specified in Schedule B.



Four laning of NH-163 from Hyderabad (ORR Appa Junction) (Design Km 14.000/Existing Km 14.000) to Manneguda (Design Km 60.405/Existing Km 59.500) (Design Length = 46.405 Km) in the State of Telangana under Bharatmala Pariyojna on Hybrid Annuity Mode

Sl. No.	Clause No.	Details of Item	Description of Deviation		
			Start Design chainage (Km)	End Design Chainage (Km)	Design Speed (Kmph)
6		Speed has been restricted at these locations due to national park and land constraints			
			14+002.148	14+031.999	20
			14+054.516	14+200.005	20
			14+229.207	14+422.022	40
			14+438.496	14+569.003	50
			14+572.144	14+782.795	50
			14+927.212	15+263.706	65
			15+521.354	15+771.774	50
			15+889.154	16+046.869	50
			16+599.090	16+755.020	80
			16+796.718	17+039.671	80
			17+128.636	17+228.653	50
			17+270.133	17+302.967	20
			17+337.590	17+352.798	20
			17+400.666	17+403.669	50
			17+519.314	17+645.194	65
			17+938.500	18+125.297	50
			28+712.663	29+124.689	80
			29+260.827	29+605.362	80
			34+844.881	35+068.960	80
35+123.829	35+365.778	80			
37+681.850	38+012.801	80			
58+773.721	58+982.851	80			
7		Radius has been reduced at these locations due to national park and land constrains	Start Design chainage (Km)	End Design Chainage (Km)	Radius (m)
			14+002.148	14+031.999	30.00
			14+054.516	14+200.005	100.00
			15+889.154	16+046.869	120.00
			17+128.636	17+228.653	180.00
			17+270.133	17+302.967	40.00
			17+337.590	17+352.798	50.00
			17+938.500	18+125.297	180.00
8	NA	Manufactures Aggregates	Ministry Circular No. RW/NH-34066/09/2017-S&R(B) dated 21.07.2020 regarding use of manufactures aggregate shall be allowed.		
9	2.10.2 (ii)	Vertical clearance of LVUP	The vertical clearance for LVUP shall be 4.0m as against of minimum 3.5m as given in clause 2.10.2 (ii) of the manual		



Four laning of NH-163 from Hyderabad (ORR Appa Junction) (Design Km 14.000/Existing Km 14.000) to Manneguda (Design Km 60.405/Existing Km 59.500) (Design Length = 46.405 Km) in the State of Telangana under Bharatmala Pariyojna on Hybrid Annuity Mode

Sl. No.	Clause No.	Details of Item	Description of Deviation
10	2.10.1	Lateral clearance of VUP/LVUP	Lateral clearance VUP/LVUP of shall be provided as mentioned in para-7 of annexure-I of Schedule-B
11	Fig 7.2B	Typical Cross Section of minor bridges	For Minor bridges at D. Ch. Km 42.921, decks width of 12.5m shall be provided instead of 10.5m.



Four laning of NH-163 from Hyderabad (ORR Appa Junction) (Design Km 14.000/Existing Km 14.000) to Manneguda (Design Km 60.405/Existing Km 59.500) (Design Length = 46.405 Km) in the State of Telangana under Bharatmala Pariyojna on Hybrid Annuity Mode

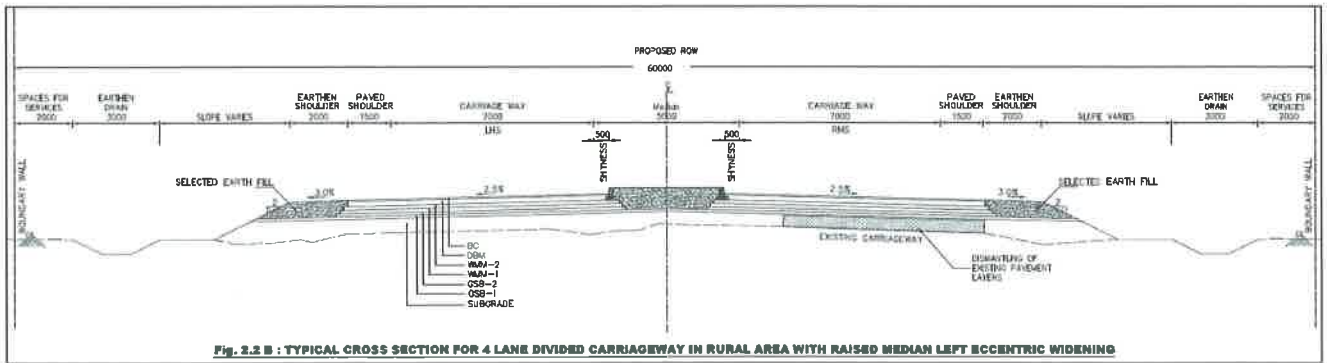
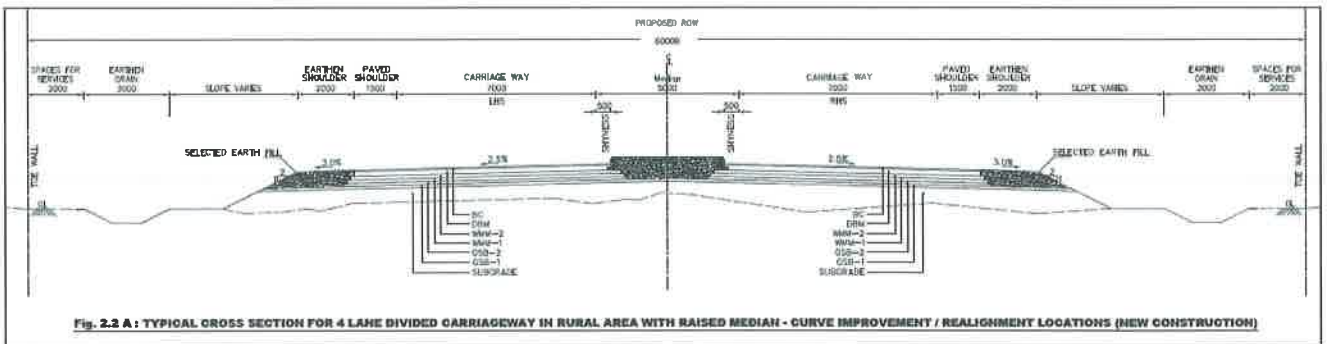

Four laning of NH-163 from Hyderabad (ORR Appa Junction) (Design Km 14.000/Existing Km 14.000) to Manneguda (Design Km 60.405/Existing Km 59.500) (Design Length = 46.405 Km) in the State of Telangana under Bharatmala Pariyojna on Hybrid Annuity Mode

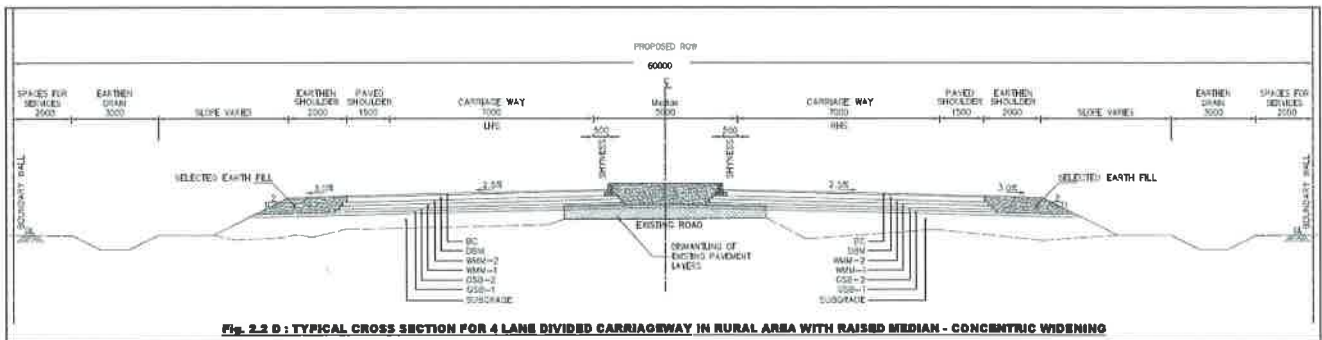
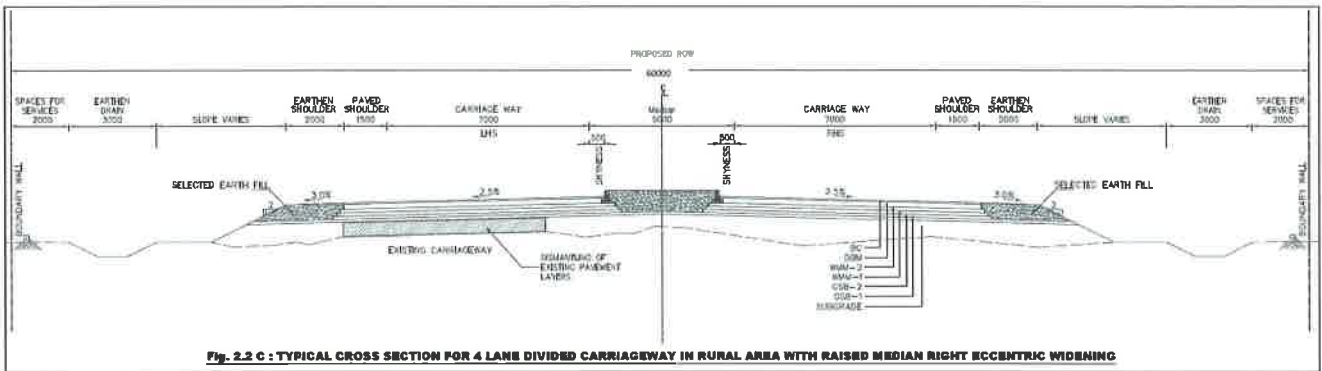

Four laning of NH-163 from Hyderabad (ORR Appa Junction) (Design Km 14.000/Existing Km 14.000) to Manneguda (Design Km 60.405/Existing Km 59.500) (Design Length = 46.405 Km) in the State of Telangana under Bharatmala Pariyojna on Hybrid Annuity Mode

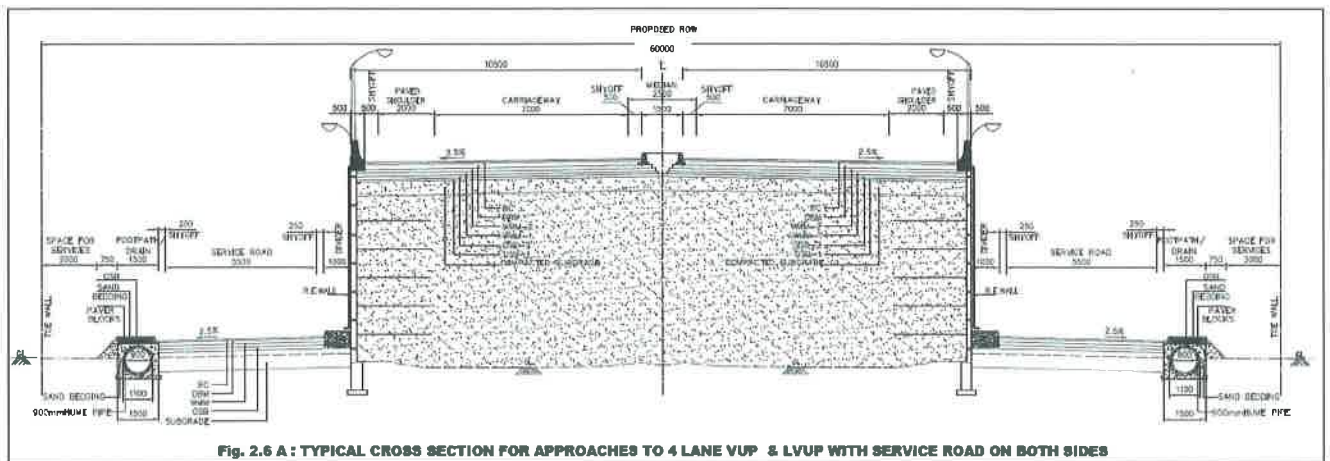
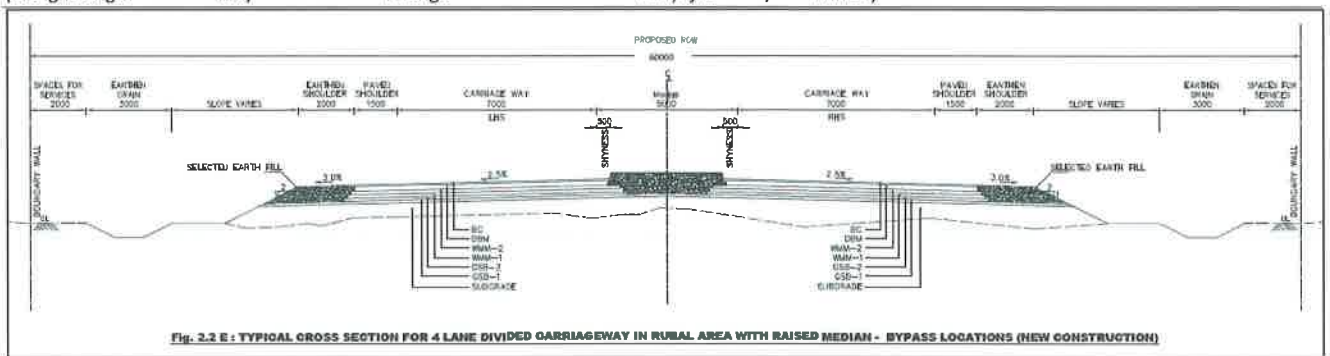

Four laning of NH-163 from Hyderabad (ORR Appa Junction) (Design Km 14.000/Existing Km 14.000) to Manneguda (Design Km 60.405/Existing Km 59.500) (Design Length = 46.405 Km) in the State of Telangana under Bharatmala Pariyojna on Hybrid Annuity Mode

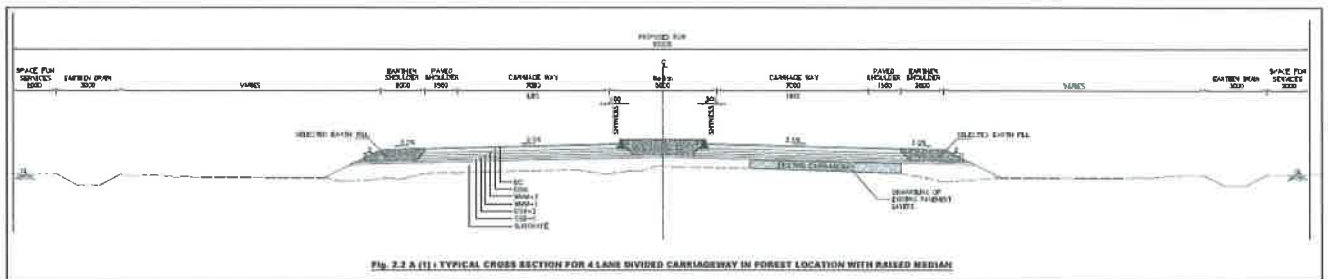
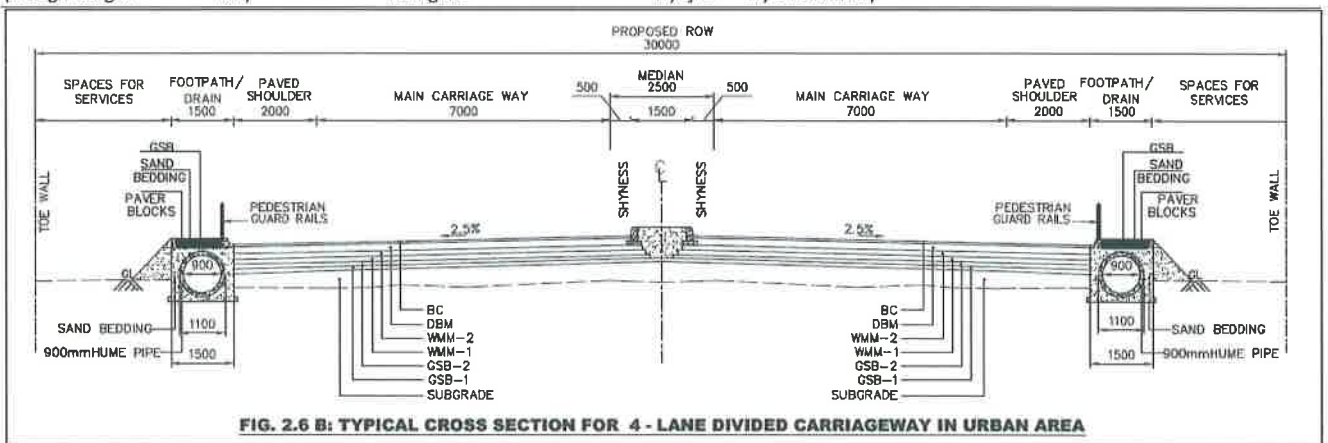

Four laning of NH-163 from Hyderabad (ORR Appa Junction) (Design Km 14.000/Existing Km 14.000) to Manneguda (Design Km 60.405/Existing Km 59.500) (Design Length = 46.405 Km) in the State of Telangana under Bharatmala Pariyojna on Hybrid Annuity Mode

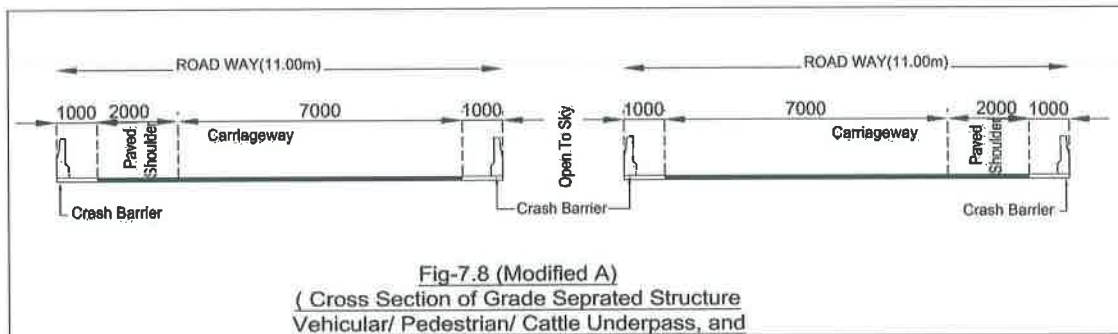

SCHEDULE - E

(See Clause 4.1.3)

APPLICABLE PERMITS

1 Applicable Permits

1.1 The Concessionaire shall obtain, as required under Applicable Laws, the following Applicable Permits on or before the Appointed Date.

Part-I

(a) Permission of the State Government for extraction of boulders from quarries for and in respect of at least 20% (twenty per cent) of the total length of the Project; and

Part-II

- (a) Permission of Village Panchayat and the Pollution Control Board for installation of crushers;
- (b) License for use of explosives;
- (c) Permission of the State Government for drawing water from river/reservoir; and
- (d) Any other permits or clearances required under Applicable Laws.

1.2 Unless otherwise specified in this Agreement, Applicable Permits, as required, relating to environmental protection and conservation shall have been procured by the Authority as a Condition Precedent.



SCHEDULE - F

(See Clause 9.1)

PERFORMANCE SECURITY

To,
The Chairman,
National Highways Authority of India
G – 5 & 6, Dwarka Sector 10,
Dwarka, New Delhi - 110075

WHEREAS:

- (A) (the “**Concessionaire**”) and the Chairman, National Highways Authority of India (the “**Authority**”) have entered into a Concession Agreement dated (the “**Agreement**”) whereby the Authority has agreed to the Concessionaire undertaking Four laning from Hyderabad (ORR Appa Junction) (Design Km 14.000/Existing Km 14.000) to Manneguda (Design Km 60.405/Existing Km 59.500) (Design Length = 46.405 Km) in the State of Telangana under NH(O) section of National Highway No. 163 on design, build, operate and transfer (“**DBOT Annuity or Hybrid Annuity**”) basis, subject to and in accordance with the provisions of the Agreement.
- (B) The Agreement requires the Concessionaire to furnish a Performance Security to the Authority in a sum of Rs. ***** cr. (Rupees ***** crore) (the “**Guarantee Amount**”) as security for due and faithful performance of its obligations, under and in accordance with the Agreement, during the Construction Period (as defined in the Agreement).
- (C) We,through our Branch at (the “**Bank**”) have agreed to furnish this Bank Guarantee by way of Performance Security.

NOW, THEREFORE, the Bank hereby, unconditionally and irrevocably, guarantees and affirms as follows:

1. The Bank hereby unconditionally and irrevocably guarantees the due and faithful performance of the Concessionaire’s obligations during the Construction Period, under and in accordance with the Agreement, and agrees and undertakes to pay to the Authority, upon its mere first written demand, and without any demur, reservation, recourse, contest or protest, and without any reference to the Concessionaire, such sum or sums upto an aggregate sum of the Guarantee Amount as the Authority shall claim, without the Authority being required to prove or to show grounds or reasons for its demand and/or for the sum specified therein.
2. A letter from the Authority, under the hand of an Officer not below the rank of General Manager in the National Highways Authority of India, that the Concessionaire has committed default in the due and faithful performance of all or any of its obligations under and in accordance with the Agreement shall be conclusive, final and binding on the Bank. The Bank further agrees that the Authority shall be the sole judge as to whether the Concessionaire is in default in due and faithful performance of its obligations during the Construction Period under the Agreement and its decision that



the Concessionaire is in default shall be final, and binding on the Bank, notwithstanding any differences between the Authority and the Concessionaire, or any dispute between them pending before any court, tribunal, arbitrators or any other authority or body, or by the discharge of the Concessionaire for any reason whatsoever.

3. In order to give effect to this Guarantee, the Authority shall be entitled to act as if the Bank were the principal debtor and any change in the constitution of the Concessionaire and/or the Bank, whether by their absorption with any other body or corporation or otherwise, shall not in any way or manner affect the liability or obligation of the Bank under this Guarantee.
4. It shall not be necessary, and the Bank hereby waives any necessity, for the Authority to proceed against the Concessionaire before presenting to the Bank its demand under this Guarantee.
5. The Authority shall have the liberty, without affecting in any manner the liability of the Bank under this Guarantee, to vary at any time, the terms and conditions of the Agreement or to extend the time or period for the compliance with, fulfilment and/ or performance of all or any of the obligations of the Concessionaire contained in the Agreement or to postpone for any time, and from time to time, any of the rights and powers exercisable by the Authority against the Concessionaire, and either to enforce or forbear from enforcing any of the terms and conditions contained in the Agreement and/or the securities available to the Authority, and the Bank shall not be released from its liability and obligation under these presents by any exercise by the Authority of the liberty with reference to the matters aforesaid or by reason of time being given to the Concessionaire or any other forbearance, indulgence, act or omission on the part of the Authority or of any other matter or thing whatsoever which under any law relating to sureties and guarantors would but for this provision have the effect of releasing the Bank from its liability and obligation under this Guarantee and the Bank hereby waives all of its rights under any such law.
6. This Guarantee is in addition to and not in substitution of any other guarantee or security now or which may hereafter be held by the Authority in respect of or relating to the Agreement or for the fulfilment, compliance and/or performance of all or any of the obligations of the Concessionaire under the Agreement.
7. Notwithstanding anything contained hereinbefore, the liability of the Bank under this Guarantee is restricted to the Guarantee Amount and this Guarantee will remain in force until the earlier of the 1st (first) anniversary of the Appointed Date or compliance of the conditions specified in paragraph 8 below and unless a demand or claim in writing is made by the Authority on the Bank under this Guarantee, no later than 6 (six) months from the date of expiry of this Guarantee, all rights of the Authority under this Guarantee shall be forfeited and the Bank shall be relieved from its liabilities hereunder.
8. The Performance Security shall cease to be in force and effect when the Concessionaire shall have expended on Project construction an aggregate sum not less than 30% (thirty per cent) of the Bid Project cost which is deemed to be Rs.*** cr. (Rupees ***** crore) for the purposes of this Guarantee, and provided the Concessionaire is not in breach of this Agreement. Upon request made by the Concessionaire for release of the Performance Security alongwith the particulars required hereunder, duly certified by a



PUBLIC PRIVATE PARTNERSHIP IN HYBRID ANNUITY PROJECTS

statutory auditor of the Concessionaire, the Authority shall release the Performance Security forthwith.

- 9. The Bank undertakes not to revoke this Guarantee during its currency, except with the previous express consent of the Authority in writing, and declares and warrants that it has the power to issue this Guarantee and the undersigned has full powers to do so on behalf of the Bank.
- 10. Any notice by way of request, demand or otherwise hereunder may be sent by post addressed to the Bank at its above referred Branch, which shall be deemed to have been duly authorised to receive such notice and to effect payment thereof forthwith, and if sent by post it shall be deemed to have been given at the time when it ought to have been delivered in due course of post and in proving such notice, when given by post, it shall be sufficient to prove that the envelope containing the notice was posted and a certificate signed by an officer of the Authority that the envelope was so posted shall be conclusive.
- 11. This Guarantee shall come into force with immediate effect and shall remain in force and effect for a period of one year and six months or until it is released earlier by the Authority pursuant to the provisions of the Agreement.
- 12. This guarantee shall also be operatable at our _____ branch at New Delhi, from whom, confirmation regarding the issue of this guarantee or extension/ renewal thereof shall be made available on demand. In the contingency of this guarantee being invoked and payment thereunder claimed, the said branch shall accept such invocation letter and make payment of amounts so demanded under the said invocation.
- 13. The guarantor/ bank hereby confirms that it is on the SFMS (Structural Finance Messaging System) platform & shall invariably send an advice of this Bank Guarantee to the designated bank of NHAI. The details are as following:

1.	Name of Beneficiary	National Highways Authority of India
2.	Name of Bank	Canara Bank
3.	Address of Bank Branch	Dwarka Sector 10 Branch
4.	Account No.	8598201005819
5.	IFSC Code	CNRB0008598

Signed and sealed this day of, 20..... at

SIGNED, SEALED AND DELIVERED

For and on behalf of

the BANK by:

(Signature)



220



PUBLIC PRIVATE PARTNERSHIP IN HYBRID ANNUITY PROJECTS

(Name)

(Designation)

(Code Number)

(Address)

NOTES:

- (i) The bank guarantee should contain the name, designation and code number of the officer(s) signing the guarantee.
- (ii) The address, telephone number and other details of the Head Office of the Bank as well as of issuing Branch should be mentioned on the covering letter of issuing Branch.



221



Annexure 1 of Schedule F
(See Clause 23.8)
Format for Guarantee for Mobilization Advance

To,
The Chairman,
National Highways Authority of India
New Delhi

WHEREAS:

- (A) (the “Concessionaire”) and the Chairman, National Highways Authority of India (the “Authority”) have entered into a Concession Agreement dated (the “Agreement”) whereby the Authority has agreed to the Concessionaire undertaking *Four laning of NH-163 from Hyderabad (ORR Appa Junction) (Design Km 14.000/Existing Km 14.000) to Manneguda (Design Km 60.405/Existing Km 59.500) (Design Length = 46.405 Km) in the State of Telangana under NH(O) on Hybrid Annuity Mode* on design, build, operate and transfer (“DBOT Annuity or Hybrid Annuity”) basis, subject to and in accordance with the provisions of the Agreement.
- (B) In accordance with Clause 23.8 of the Agreement, the Authority shall make to the Concessionaire an interest bearing (@average of one year MCLR of top 5 Scheduled Commercial Banks plus 1.25% compounded Annually) advance payment (herein after called “Mobilization Advance”) not exceeding 10% (ten per cent) of the Bid Project Cost; and that the Mobilization Advance shall be made in [one/two] installment(s) subject to the concessionaire furnishing an irrevocable and unconditional guarantee by a scheduled bank for an amount equivalent to 110% (one hundred and ten percent) of such installment to remain effective till the complete and full payment of the installment of the Mobilization Advance as security for compliance with its obligations in accordance with the Agreement. The amount of {first/second} installment of the Mobilization Advance is Rs.----- Cr. (Rupees----- Crore) and the amount of this Guarantee is Rs. ---- Cr. (Rupees---- crore) (the “Guarantee Amount”)⁹.
- (C) We,through our branch at (the “Bank”) have agreed to furnish this bank guarantee (hereinafter called the “Guarantee”) for the Guarantee Amount.

NOW, THEREFORE, the Bank hereby, unconditionally and irrevocably, guarantees and affirms as follows:

1. The Bank hereby unconditionally and irrevocably guarantees the due and faithful repayment on time of the aforesaid installment of Mobilization Advance under and in accordance with the Agreement, and agrees and undertakes to pay to the Authority, upon its mere first written demand, and without any demur, reservation, recourse, contest or protest, and without any reference to the Concessionaire, such sum or sums upto an aggregate sum of the Guarantee Amount as the Authority shall claim, without the Authority being required to prove or to show grounds or reasons for its demand and/or for the sum specified therein.
2. A letter from the Authority, under the hand of an Officer not below the rank of General

⁹ The Guarantee amount should be equivalent to 110% of the value of the applicable installment.

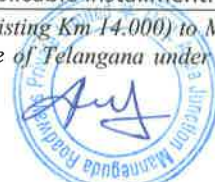

Manager in the National Highways Authority of India, that the Concessionaire has committed default in the due and faithful performance of all or any of its obligations for the repayment of the installment of the Mobilization Advance under and in accordance with the Agreement shall be conclusive, final and binding on the Bank. The Bank further agrees that the Authority shall be the sole judge as to whether the Concessionaire is in default in due and faithful performance of its obligations during and under the Agreement and its decision that the Concessionaire is in default shall be final, and binding on the Bank, notwithstanding any differences between the Authority and the Concessionaire, or any dispute between them pending before any court, tribunal, arbitrators or any other authority or body, or by the discharge of the Concessionaire for any reason whatsoever.

3. The Bank further also agrees that the Authority at its option shall be entitled to in enforce this Guarantee against the Bank as principal debtor, in the first instance without proceeding against the Concessionaire and notwithstanding any security or other guarantee that the Authority may have in relation to the Concessionaire's liability.
4. In order to give effect to this Guarantee, the Authority shall be entitled to act as if the Bank were the principal debtor and any change in the constitution of the Concessionaire and/or the Bank, whether by their absorption with any other body or corporation or otherwise, shall not in any way or manner affect the liability or obligation of the Bank under this Guarantee.
5. It shall not be necessary, and the Bank hereby waives any necessity, for the Authority to proceed against the Concessionaire before presenting to the Bank its demand under this Guarantee.
6. The Authority shall have the liberty, without affecting in any manner the liability of the Bank under this Guarantee, to vary at any time, the terms and conditions of the Mobilization Advance or to extend the time or period of its repayment or to postpone for any time, and from time to time, any of the rights and powers exercisable by the Authority against the Concessionaire, and either to enforce or forbear from enforcing any of the terms and conditions contained in the Agreement and/or the securities available to the Authority, and the Bank shall not be released from its liability and obligation under these presents by any exercise by the Authority of the liberty with reference to the matters aforesaid or by reason of time being given to the Concessionaire or any other forbearance, indulgence, act or omission on the part of the Authority or of any other matter or thing whatsoever which under any law relating to sureties and guarantors would but for this provision have the effect of releasing the Bank from its liability and obligation under this Guarantee and the Bank hereby waives all of its rights under any such law.
7. This Guarantee is in addition to and not in substitution of any other guarantee or security now or which may hereafter be held by the Authority in respect of or relating to the Mobilization Advance.
8. Notwithstanding anything contained hereinbefore, the liability of the Bank under this Guarantee is restricted to the Guarantee Amount and this Guarantee will remain in force for the period specified in paragraph 9 below and unless a demand or claim in writing is made by the Authority on the Bank under this Guarantee all rights of the Authority under this Guarantee shall be forfeited and the Bank shall be relieved from its liabilities hereunder.



PUBLIC PRIVATE PARTNERSHIP IN HYBRID ANNUITY PROJECTS

9. The Guarantee shall cease to be in force and effect on _____¹⁰ unless a demand or claim under this Guarantee is made in writing on or before the aforesaid date, the Bank shall be discharged from its liabilities hereunder.
10. The Bank undertakes not to revoke this Guarantee during its currency, except with the previous express consent of the Authority in writing, and declares and warrants that it has the power to issue this Guarantee and the undersigned has full powers to do so on behalf of the Bank.
11. Any notice by way of request, demand or otherwise hereunder may be sent by post addressed to the Bank at its above referred Branch, which shall be deemed to have been duly authorised to receive such notice and to effect payment thereof forthwith, and if sent by post it shall be deemed to have been given at the time when it ought to have been delivered in due course of post and in proving such notice, when given by post, it shall be sufficient to prove that the envelope containing the notice was posted and a certificate signed by an officer of the Authority that the envelope was so posted shall be conclusive.
12. This Guarantee shall come into force with immediate effect and shall remain in force and effect up to the date specified in paragraph 9 above or until it is released earlier by the Authority pursuant to the provisions of the Agreement.
13. This guarantee shall be operable at ourBranch at New Delhi, from whom, confirmation regarding the issue of this guarantee or extension/renewal thereof shall be made available on demand. In the contingency of this guarantee being invoked and payment thereunder claimed, the said branch shall accept such invocation letter and make payment of amounts so demanded under the said invocation.
14. The guarantor/bank hereby confirms that it is on the SFMS (Structural Finance Messaging System) platform & shall invariably send an advice of this Bank Guarantee to the designated bank of NHAI, the details of which are as follows:.

S. No.	Particulars	Details
1.	Name of Beneficiary	National Highways Authority of India
2.	Name of Bank	Canara Bank
3.	Address of Bank Branch	Dwarka, Sector-10 Branch
4.	Account No.	8598201005819
5.	IFSC Code	CNRB0008598

Signed and sealed this day of, 20..... at

SIGNED, SEALED AND DELIVERED

¹⁰ Initially the validity shall be 60 days after the expected date for **tenth** payment milestone mentioned in clause 23.4 of the Agreement. If the Concessionaire submits the Guarantee which has validity period which is less than that specified herein, then the Concessionaire shall also provide an undertaking to the Authority which states that the Concessionaire shall get the validity of the Guarantee extended so that the Guarantee is valid in accordance with the footnote.



For and on behalf of
the BANK by:

(Signature)

(Name)

(Designation)

(Code Number)

(Address)

NOTES:

- (i) The bank guarantee should contain the name, designation and code number of the officer(s) signing the guarantee.
- (iii) The address, telephone number and other details of the Head Office of the Bank as well as of issuing Branch should be mentioned on the covering letter of issuing Branch.



SCHEDULE - G

(See Clause 12.1)

PROJECT COMPLETION SCHEDULE

1 Project Completion Schedule

During Construction Period, the Concessionaire shall comply with the requirements set forth in this Schedule-G for each of the Project Milestones and the Scheduled Completion Date (the "Project Completion Schedule"). Within 15 (fifteen) days of the date of each Project Milestone, the Concessionaire shall notify the Authority of such compliance along with necessary particulars thereof.

2 Project Milestone-I

2.1 Project Milestone-I shall occur on the date falling on the 230th (Two Hundred and Thirtieth) day from the Appointed Date (the "Project Milestone-I").

2.2 Prior to the occurrence of Project Milestone-I, the Concessionaire shall have expended not less than 20% (twenty per cent) of the total capital cost set forth in the Financial Package.

2.3 Prior to the occurrence of Project Milestone –I, the Concessionaire shall have commenced construction of the Project and achieved 20% Physical Progress.

3 Project Milestone-II

3.1 Project Milestone-II shall occur on the date falling on the 340th (Three hundred and fortieth) day from the Appointed Date (the "Project Milestone-II").

3.2 Prior to the occurrence of Project Milestone-II, the Concessionaire shall have expended not less than 35% (thirty five per cent) of the total capital cost set forth in the Financial Package. Provided, however, that at least 70% (seventy per cent) of the expenditure referred to hereinabove shall have been incurred on physical works which shall not include advances of any kind to any person or expenditure of any kind on plant and machinery.

3.3 Prior to the occurrence of Project Milestone –II, the Concessionaire shall have commenced construction of the Project and achieved 35% Physical Progress

4 Project Milestone-III

4.1 Project Milestone-III shall occur on the date falling on the 550th (Five hundred and fiftieth) day from the Appointed Date (the "Project Milestone-III").

4.2 Prior to the occurrence of Project Milestone-III, the Concessionaire shall have commenced construction of all Project Facilities and expended not less than 75% (seventy five per cent) of the total capital cost set forth in the Financial Package.

4.3 Prior to the occurrence of Project Milestone –III, the Concessionaire shall have commenced construction of the Project and achieved 75% Physical Progress

5 Scheduled Completion Date

- 5.1 The Scheduled Completion Date shall be the 730th (Seven hundred and thirtieth) day from the Appointed Date.
- 5.2 On or before the Scheduled Completion Date, the Concessionaire shall have completed the Project in accordance with this Agreement.

6 Extension of period

Upon extension of any or all of the aforesaid Project Milestones or the Scheduled Completion Date, as the case may be, under and in accordance with the provisions of this Agreement, the Project Completion Schedule shall be deemed to have been amended accordingly.



Annexure-I of Schedule G

Format for Contract Price Weightages for Highway Projects with Flexible Pavements

Contract Price Weightages

1.1 The Contract Price for this Agreement is Rs. 785 Crore
(Rupees Seven Hundred Eighty Five Crores Only)

1.2 Proportions of the Contract Price for different stages of Construction of the Project Highway shall be as specified below:

Item	Stage for measurement of Physical Progress	Unit	Qty.	Weightage in percentage to the Contract Price
1	2	3	4	5
Road works including culverts, minor bridges, underpasses, overpasses, approaches to ROB/RUB/ Major Bridges/ Structures (but excluding service roads)	A- Widening and strengthening of existing road			
	(1) Earthwork up to top of the sub-grade	Km	***	***
	(2) Granular work (sub- base, base, shoulders)			
	(a) GSB	Km	***	***
	(b) WMM	Km	***	***
	(3) Shoulders	Km	***	***
	(4) Bituminous work			
	(a) DBM	Km	***	***
	(b) BC	Km	***	***
	(5) Rigid Pavement			
	Concrete work	Km	***	***
	(6) Widening and repair of culverts	No.	***	***
	(7) Widening and repair of minor bridges	No.	***	***
	B- New realignment/bypass			
	(1) Earthwork up to top of the sub-grade	Km	***	***
	(2) Granular work (sub- base, base, shoulders)			
	(a) GSB	Km	***	***
	(b) WMM	Km	***	***
	(3) Shoulders	Km	***	***
	(4) Bituminous work			
(a) DBM	Km	***	***	
(b) BC	Km	***	***	

Four laning of NH-163 from Hyderabad (ORR Appa Junction) (Design Km 14.000/Existing Km 14.000) to Manneguda (Design Km 60.405/Existing Km 59.500) (Design Length = 46.405 Km) in the State of Telangana under NH(O) on Hybrid Annuity Mode Page 161



PUBLIC PRIVATE PARTNERSHIP IN HYBRID ANNUITY PROJECTS

(5) Rigid Pavement			
Concrete work	Km	***	***
C- New culverts, minor bridges, underpasses, overpasses on existing road, realignments, bypasses:			
(1) Culverts	No.	***	***
(2) Minor bridges			
(a) Foundation	No.	***	***
(b) Sub-structure	No.	***	***
(c) Super-structure (including crash barriers etc. complete)	No.	***	***
(3) Cattle/Pedestrian underpasses			
(a) Foundation	No.	***	***
(b) Sub-structure	No.	***	***
(c) Super-structure (including crash barriers etc. complete)	No.	***	***
(4) Pedestrian overpasses			
(a) Foundation	No.	***	***
(b) Sub-structure	No.	***	***
(c) Super-structure (including crash barriers etc. complete)	No.	***	***
(5) Grade separated structures			
(a) Underpasses			
(i) Foundation	No.	***	***
(ii) Sub-structure	No.	***	***
(iii) Super-structure (including crash barriers etc. complete)	No.	***	***
(b) Overpass			
(i) Foundation	No.	***	***
(ii) Sub-structure	No.	***	***
(iii) Super-structure (including crash barriers etc. complete)	No.	***	***
(c) Flyover			
(i) Foundation	No.	***	***
(ii) Sub-structure	No.	***	***
(iii) Super-structure (including crash barriers etc. complete)	No.	***	***



PUBLIC PRIVATE PARTNERSHIP IN HYBRID ANNUITY PROJECTS

	(d) Foot over Bridge	No.	***	***
Major Bridge works and ROB/RUB	A- Widening and repairs of Major Bridges			
	(1) Foundation			
	(a) Open Foundation	No.	***	***
	(b) Pile Foundation/Well Foundation	No.	***	***
	(2) Sub-structure	No.	***	***
	(3) Super-structure (including crash barriers etc. complete)	No.	***	***
	B- Widening and repair of			
	(a) ROB			
	(1) Foundation	No.	***	***
	(2) Sub-structure	No.	***	***
	(3) Super-structure (including crash barriers etc. complete)	No.	***	***
	(b) RUB			
	(1) Foundation	No.	***	***
	(2) Sub-structure	No.	***	***
	(3) Super-structure (including crash barriers etc. complete)	No.	***	***
	C- New Major Bridges			
	(1) Foundation	No.	***	***
	(a) Open Foundation	No.	***	***
	(b) Pile Foundation/Well Foundation	No.	***	***
	(2) Sub-structure	No.	***	***
	(3) Super-structure (including crash barriers etc. complete)	No.	***	***
	D- New rail-road bridges			
	(a) ROB			
	(1) Foundation	No.	***	***
	(2) Sub-structure	No.	***	***
	(3) Super-structure (including crash barriers etc. complete)	No.	***	***
	(b) RUB			
	(1) Foundation	No.	***	***
(2) Sub-structure	No.	***	***	
(3) Super-structure (including crash barriers etc. complete)	No.	***	***	

Four laning of NH-163 from Hyderabad (ORR Appa Junction) (Design Km 14.000/Existing Km 14.000) to Manneguda (Design Km 60.405/Existing Km 59.500) (Design Length = 46.405 Km) in the State of Telangana under NH(O) on Hybrid Annuity Mode Page 163



PUBLIC PRIVATE PARTNERSHIP IN HYBRID ANNUITY PROJECTS

Structures (elevated sections, reinforced earth)	(1) Foundation	No.	***	***
	(2) Sub-structure	No.	***	***
	(3) Super-structure (including crash barriers etc. complete)	No.	***	***
	(4) Reinforced Earth Wall (includes Approaches of ROB, Underpasses, Overpasses, Flyover etc.	Sqm	***	***
Electrical and Public Health Utilities Electrical and Public Health Utilities	EHT line	Km	***	***
	EHT crossing	No.	***	***
	HT/LT lines (including Transformers if any)	Km	***	***
	HT/LT crossings	No.	***	***
	Water pipeline	Km	***	***
	Water pipeline crossings	No.	***	***
	Sewage line	Km	***	***
	Sewage line crossings	No.	***	***
	EHT line	Km	***	***
Other Works	(i) Service roads/ Slip Roads	Km	***	***
	(ii) Toll Plaza	No.	***	***
	(iii) Road side drains	Km	***	***
	(iv) Road signs, markings, km stones, safety devices,			
	(a) Road signs, markings, km stones,	Km	***	***
	(b) Concrete Crash Barrier/ W-Beam Crash Barrier in Road work	Km	***	***
	(v) Project facilities			
	(a) Bus bays	No.	***	***
	(b) Truck lay-byes	No.	***	***
	(c) Rest areas	No.	***	***
	(vi) Repairs to bridges/structures	No.	***	***
	(vii) Road side plantation	Km	***	***
	(viii) Protection works			
	(a) Boulder Pitching on slopes	Km	***	***
	(b) Toe/Retaining wall	Km	***	***
	(ix) Tunnel			
	(a) Excavation	Metre	***	***
	(b) Construction of support system including rock bolting, lining etc.	Metre	***	***

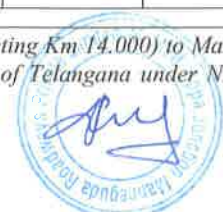

PUBLIC PRIVATE PARTNERSHIP IN HYBRID ANNUITY PROJECTS

	(c) On complete completion of tunnel	Metre	[***]	[***]
	(x) Miscellaneous	Lump sum	[***]	[***]
Total				100.00%

* The above list is illustrative and may require modification as per the scope of the work.

**** Measurement of Progress**

For example, if the total length of bituminous work to be done is 100 km, the physical progress of bituminous work shall be determined as follows:

Physical progress of bituminous work = Weightage
for bituminous work x (L'/L)

L = Total length of bituminous work in km

L' = Executed length of bituminous work in km

Similarly, the physical progress for other stages shall be worked out and addition of all will give the total progress achieved.



Annexure-I of Schedule G

Format for Contract Price Weightages for Highway Projects with Rigid Pavements

Contract Price Weightages

1.1 The Contract Price for this Agreement is Rs. 785 Crore
(Rupees Seven Hundred Eighty Five Crores Only)

1.2 Proportions of the Contract Price for different stages of Construction of the Project Highway shall be as specified below:

Item	Stage for measurement of Physical Progress	Unit	Qty.	Weightage in percentage to the Contract Price
1	2	3	4	5
Road works including culverts, minor bridges, underpasses, overpasses, approaches to ROB/RUB/ Major Bridges/ Structures (but excluding service roads)	A- Widening and strengthening of existing road			
	(1) Earthwork up to top of the sub-grade	Km	***	***
	(2) Granular work (sub- base, shoulders)			
	GSB	Km	***	***
	(3) Shoulders	Km	***	***
	(4) Bituminous work	Km	***	***
	(5) Rigid Pavement			
	(a) DLC	Km	***	***
	(b) PQC	Km	***	***
	(6) Widening and repair of culverts	No.	***	***
	(7) Widening and repair of minor bridges	No.	***	***
	B- New realignment/bypass			
	(1) Earthwork up to top of the sub-grade	Km	***	***
	(2) Granular work (sub- base, shoulders)			
	GSB	Km	***	***
	(3) Shoulders	Km	***	***
	(4) Bituminous work	Km	***	***
	(5) Rigid Pavement			
	(a) DLC	Km	***	***
	(b) PQC	Km	***	***

233

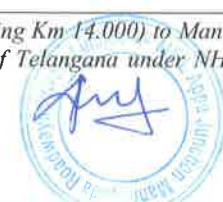

PUBLIC PRIVATE PARTNERSHIP IN HYBRID ANNUITY PROJECTS

	C- New culverts, minor bridges, underpasses, overpasses on existing road, realignments, bypasses:			
	(1) Culverts	No.	[***]	[***]
	(2) Minor bridges			
	(a) Foundation	No.	[***]	[***]
	(b) Sub-structure	No.	[***]	[***]
	(c) Super-structure (including crash barriers etc. complete)	No.	[***]	[***]
	(3) Cattle/Pedestrian underpasses			
	(a) Foundation	No.	[***]	[***]
	(b) Sub-structure	No.	[***]	[***]
	(c) Super-structure (including crash barriers etc. complete)	No.	[***]	[***]
	(4) Pedestrian overpasses			
	(a) Foundation	No.	[***]	[***]
	(b) Sub-structure	No.	[***]	[***]
	(c) Super-structure (including crash barriers etc. complete)	No.	[***]	[***]
	(5) Grade separated structures			
	(a) Underpasses			
	(i) Foundation	No.	[***]	[***]
	(ii) Sub-structure	No.	[***]	[***]
	(iii) Super-structure (including crash barriers etc. complete)	No.	[***]	[***]
	(b) Overpass			
	(i) Foundation	No.	[***]	[***]
	(ii) Sub-structure	No.	[***]	[***]
	(iii) Super-structure (including crash barriers etc. complete)	No.	[***]	[***]
	(c) Flyover			
	(i) Foundation	No.	[***]	[***]
	(ii) Sub-structure	No.	[***]	[***]
	(iii) Super-structure (including crash barriers etc. complete)	No.	[***]	[***]
	(d) Foot over Bridge	No.	[***]	[***]
Major Bridge works and ROB/RUB	A- Widening and repairs of Major Bridges			
	(1) Foundation			
	(a) Open Foundation	No.	[***]	[***]



PUBLIC PRIVATE PARTNERSHIP IN HYBRID ANNUITY PROJECTS

	(b) Pile Foundation/Well Foundation	No.	[***]	[***]
	(2) Sub-structure	No.	[***]	[***]
	(3) Super-structure (including crash barriers etc. complete)	No.	[***]	[***]
	B- Widening and repair of			
	(a) ROB			
	(1) Foundation	No.	[***]	[***]
	(2) Sub-structure	No.	[***]	[***]
	(3) Super-structure (including crash barriers etc. complete)	No.	[***]	[***]
	(b) RUB			
	(1) Foundation	No.	[***]	[***]
	(2) Sub-structure	No.	[***]	[***]
	(3) Super-structure (including crash barriers etc. complete)	No.	[***]	[***]
	C- New Major Bridges			
	(1) Foundation	No.	[***]	[***]
	(a) Open Foundation	No.	[***]	[***]
	(b) Pile Foundation/Well Foundation	No.	[***]	[***]
	(2) Sub-structure	No.	[***]	[***]
	(3) Super-structure (including crash barriers etc. complete)	No.	[***]	[***]
	D- New rail-road bridges			
	(a) ROB			
	(1) Foundation	No.	[***]	[***]
	(2) Sub-structure	No.	[***]	[***]
	(3) Super-structure (including crash barriers etc. complete)	No.	[***]	[***]
	(b) RUB			
	(1) Foundation	No.	[***]	[***]
	(2) Sub-structure	No.	[***]	[***]
	(3) Super-structure (including crash barriers etc. complete)	No.	[***]	[***]
Structures (elevated sections, reinforced earth)	(1) Foundation	No.	[***]	[***]
	(2) Sub-structure	No.	[***]	[***]
	(3) Super-structure (including crash barriers etc. complete)	No.	[***]	[***]

235



PUBLIC PRIVATE PARTNERSHIP IN HYBRID ANNUITY PROJECTS

	(4) Reinforced Earth Wall (includes Approaches of ROB, Underpasses, Overpasses, Flyover etc.	Sqm	***	***
Electrical and public health utilities	EHT line	Km	***	***
	EHT crossing	No.	***	***
	HT/LT lines (including Transformers if any)	Km	***	***
	HT/LT crossings	No.	***	***
	Water pipeline	Km	***	***
	Water pipeline crossings	No.	***	***
	Sewage line	Km	***	***
	Sewage line crossings	No.	***	***
Other Works	(i) Service roads/ Slip Roads	Km	***	***
	(ii) Toll Plaza	No.	***	***
	(iii) Road side drains	Km	***	***
	(iv) Road signs, markings, km stones, safety devices,			
	(a) Road signs, markings, km stones,	Km	***	***
	(b) Concrete Crash Barrier/ W- Beam Crash Barrier in Road work	Km	***	***
	(v) Project facilities			
	(a) Bus bays	No.	***	***
	(b) Truck lay-byes	No.	***	***
	(c) Rest areas	No.	***	***
	(vi) Repairs to bridges/structures	No.	***	***
	(vii) Road side plantation	Km	***	***
	(viii) Protection works			
	(a) Boulder Pitching on slopes	Km	***	***
	(b) Toe/Retaining wall	Km	***	***
	(ix) Tunnel			
	(a) Excavation	Metre	***	***
	(b) Construction of support system including rock bolting, lining etc.	Metre	***	***
	(c) On complete completion of tunnel	Metre	***	***
	(x) Miscellaneous	Lump sum	***	***
Total				100.00%

* The above list is illustrative and may require modification as per the scope of the work.



**** Measurement of Progress**

For example, if the total length of bituminous work to be done is 100 km, the physical progress of bituminous work shall be determined as follows:

Physical progress of bituminous work = Weightage
for bituminous work x (L'/L)

L = Total length of bituminous work in km

L' = Executed length of bituminous work in km

Similarly, the physical progress for other stages shall be worked out and addition of all will give the total progress achieved.



SCHEDULE - H
(See Clause 12.2)
DRAWINGS

1 Drawings

In compliance of the obligations set forth in Clause 12.2 of this Agreement, the Concessionaire shall furnish to the Independent Engineer, free of cost, all Drawings listed in Annex-I of this Schedule-H.

2 Additional drawings

If the Independent Engineer determines that for discharging its duties and functions under this Agreement, it requires any drawings other than those listed in Annex-I, it may by notice require the Concessionaire to prepare and furnish such drawings forthwith. Upon receiving a requisition to this effect, the Concessionaire shall promptly prepare and furnish such drawings to the Independent Engineer, as if such drawings formed part of Annex-I of this Schedule-H.



Annex - I (Schedule-H)

List of Drawings

A minimum list of the drawings of the various components / elements of the Project Highway and project facilities required to be submitted by the Concessionaire is given below:

- (a). Horizontal and Vertical Alignment with details of reference pillars. Horizontal intersection Point, Vertical Intersection Points, elements of curves, and sight distances.
- (b). Cross-section at 10m interval along the alignment within ROW.
- (c). Drawings of cross drainage works.
- (d). Typical Cross-section with details of pavement structures.
- (e). Detailed drawings of individual Bridges / Structures/ interchanges.
- (f). Detailed drawings for individual culverts.
- (g). Detailed layout drawings for intersections and interchanges.
- (h). Drawings for Road sign, Toll Plaza Layout, Toll Collection systems, roadway near toll plaza, Bus bays, Parking areas, Truck lay byes with furniture and drainage system, etc.
- (i). Drawings of road furniture items including traffic signage, markings, safety barriers, etc.
- (j). Detailed layout drawings for traffic circulation for service roads/ slip roads and detailed drawings for underpasses including cross-section drawings through underpasses at the project road level and the structures bed level.
- (k). Drawings for Landscaping, Horticulture & Tree Plantation.
- (l). Drawing of control center.
- (m). Wayside Amenities/Service area/Parking area.
- (n). Traffic Management drawings for safety in construction zones.
- (o). Drawings for traffic diversion plans and traffic control measures in construction zones.
- (p). Drawings of road drainage measures.
- (q). Drawings of typical details slope protection measures.
- (r). Drawings of street lighting. General arrangement of base camp and administrative block.
- (s). Any other drawing relevant to the Project Highway as desired by Authority/IE.



SCHEDULE - I

(See Clause 14.1.2)

TESTS

1 Schedule for Tests

- 1.1 The Concessionaire shall, no later than 30 (thirty) days prior to the likely completion of the Project, notify the Independent Engineer and the Authority of its intent to subject the Project to Tests, and no later than 7 (seven) days prior to the actual date of Tests, furnish to the Independent Engineer and the Authority detailed inventory and particulars of all works and equipment forming part of the Project.
- 1.2 The Concessionaire shall notify the Independent Engineer of its readiness to subject the Project to Tests at any time after 7 (seven) days from the date of such notice, and upon receipt of such notice, the Independent Engineer shall, in consultation with the Concessionaire, determine the date and time for each Test and notify the same to the Authority who may designate its representative to witness the Tests. The Independent Engineer shall thereupon conduct the Tests itself or cause any of the Tests to be conducted in accordance with Article 14 and this Schedule-I.

2 Tests

- 2.1 In pursuance of the provisions of Clause 14.1.2 of this Agreement, the Independent Engineer shall conduct, or cause to be conducted, the Tests specified in this Paragraph 2.
- 2.2 Visual and physical Test: The Independent Engineer shall conduct a visual and physical check of the Project to determine that all works and equipment forming part thereof conform to the provisions of this Agreement.
- 2.3 Test drive: The Independent Engineer shall undertake a test drive of the Project by a Car and by a fully loaded Truck to determine that the quality of service conforms to the provisions of the Agreement.
- 2.4 Riding quality Test: Riding quality of each lane of the carriageway shall be checked with the help of a calibrated bump integrator and the maximum permissible roughness for purposes of this Test shall be 1,800 (one thousand and eight hundred) mm for each kilometer.
- 2.5 Pavement Composition Test: The thickness and composition of the pavement structure shall be checked on a sample basis by digging pits to determine conformity of such pavement structure with Specifications and Standards. The sample shall consist of one pit in each direction of travel to be chosen at random in each stretch of 5 (five) kilometers of the Project. The first pit for the sample shall be selected by the Independent Engineer through an open draw of lots and every fifth kilometer from such first pit shall form part of the sample for this pavement quality Test.
- 2.6 Cross-section Test: The cross-sections of the Project shall be checked on a sample basis through physical measurement of their dimensions for determining the conformity thereof with Specifications and Standards. For the road portion, the sample shall consist



of one spot to be selected at random in each stretch of 1(one) kilometer of the Project. The first spot for the sample shall be selected by the Independent Engineer through an open draw of lots and the spots located at every one kilometer from such first spot shall form part of the sample. For the bridge portion, one spot shall be selected at random by the Independent Engineer in each span of the bridge.

- 2.7 Structural Test for bridges: All major and minor bridges, including over bridges, underpasses and flyovers, constructed by the Concessionaire shall be subjected to the Rebound Hammer and Ultrasonic Pulse Velocity tests, to be conducted in accordance with the procedure described in Special Report No. 17: 1996 of the IRC Highway Research Board on Non-destructive Testing Techniques, at two spots in every span, to be chosen at random by the Independent Engineer. Bridges with a span of 15 (fifteen) meters or more shall also be subjected to load testing.
- 2.8 Other Tests: The Independent Engineer may require the Concessionaire to carry out or cause to be carried additional Tests, in accordance with Good Industry Practice, for determining the compliance of the Project with Specifications and Standards.
- 2.9 Environmental audit: The Independent Engineer shall carry out a check to determine conformity of the Project with the environmental requirements set forth in Applicable Laws and Applicable Permits.
- 2.10 Safety review: Safety audit of the Project shall have been undertaken by the Safety Consultant as set forth in Schedule-L, and on the basis of such audit, the Independent Engineer shall determine conformity of the Project with the provisions of this Agreement.

3 Agency for conducting Tests

All Tests set forth in this Schedule-I shall be conducted by the Independent Engineer or such other agency or person as it may specify in consultation with the Authority.

4 Completion/Provisional Certificate

Upon successful completion of Tests, the Independent Engineer shall issue the Completion Certificate or the Provisional Certificate, as the case may be, in accordance with the provisions of Article 14.

5 Tests during construction

Without prejudice to the provisions of this Schedule-I, tests during construction shall be conducted In accordance with the provisions of Clause 13.3.1.



SCHEDULE - J

(See Clause 14.2 & 14.3)

COMPLETION CERTIFICATE

- 1 I/We,..... (Name of the Independent Engineer), acting as Independent Engineer, under and in accordance with the Concession Agreement dated(the "Agreement"), for development and operation of the **Four laning of NH-163 from Hyderabad (ORR Appa Junction) (Design Km 14.000/Existing Km 14.000) to Manneguda (Design Km 60.405/Existing Km 59.500) (Design Length = 46.405 Km) in the State of Telangana under NH(O) Project** (the "Project") on design, build, operate and transfer (the "DBOT Annuity or Hybrid Annuity") basis, through.....(Name of Concessionaire), hereby certify that the Tests specified in Article 14 and Schedule-I of the Agreement have been successfully undertaken to determine compliance of the Project with the provisions of the Agreement, and I/We am/are satisfied that the Project can be safely and reliably placed in commercial service of the Users thereof..
- 2 It is certified that Rain Water Harvesting and Artificial recharging arrangements have been provided by the Concessionaire as per schedule –B of the Concession Agreement, and are functional. Details (with locationChainage) are as given in Annex_____.
- 3 It is certified that, in terms of the aforesaid Agreement, all works forming part of the Project have been completed, and the Project is hereby declared fit for entry into commercial operation on this the day of 20

SIGNED, SEALED AND DELIVERED

For and on behalf of

INDEPENDENT ENGINEER by:

(Signature)

(Name)

(Designation)

(Address)

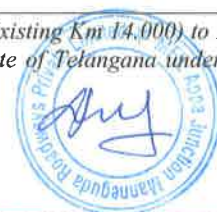

PROVISIONAL CERTIFICATE

- 1 I/We,..... (Name of the Independent Engineer), acting as Independent Engineer, under and in accordance with the Concession Agreement Dated..... (the "Agreement"), for development and operation of the Construction of **Four laning of NH-163 from Hyderabad (ORR Appa Junction) (Design Km 14.000/Existing Km 14.000) to Manneguda (Design Km 60.405/Existing Km 59.500) (Design Length = 46.405 Km) in the State of Telangana under NH(O) Project** (the "Project") on design, build, operate and transfer (the "DBOT Annuity or Hybrid Annuity") basis through.....(Name of Concessionaire), hereby certify that the Tests specified in Article 14 and Schedule-I of the Agreement have been undertaken for the Project/section..... of the Project to determine compliance thereof with the provisions of the Agreement.

- 2 Construction Works forming part of the Project/section of the Project that were found to be incomplete and/or deficient have been specified in the Punch List appended hereto, and the Concessionaire has agreed and accepted that it shall complete and/or rectify all such works in the time and manner set forth in the Agreement. Some of the incomplete works have been delayed as a result of reasons attributable to the Authority or due to Force Majeure and the Provisional Certificate cannot be withheld on this account. Though the remaining incomplete works have been delayed as a result of reasons attributable to the Concessionaire,^δ I/We am/are satisfied that having regard to the nature and extent of such incomplete works, it would not be prudent to withhold commercial operation of the Project/section..... of the Project, pending completion thereof.

- 3 In view of the foregoing, I/We am/are satisfied that the Project/section of the Project can be safely and reliably placed in commercial service of the Users thereof, and in terms of the Agreement, the Project/section of the Project is hereby provisionally declared fit for entry into commercial operation on this the day of..... 20

ACCEPTED, SIGNED, SEALED

AND DELIVERED

FOR AND ON BEHALF OF

CONCESSIONAIRE by:

(Signature)

(Name and Designation)

(Address)

SIGNED, SEALED AND

DELIVERED

FOR AND ON BEHALF OF

INDEPENDENT ENGINEER by:

(Signature)

(Name and Signature)

(Address)

^δMay be struck out if not applicable. Also strike out other parts which are not applicable.



SCHEDULE - K

(See Clause 17.2)

MAINTENANCE REQUIREMENTS

1 Maintenance Requirements

- 1.1 The Concessionaire shall, at all times, operate and maintain the Project in accordance with the provisions of the Agreement, Applicable Laws and Applicable Permits. In particular, the Concessionaire shall, at all times during the Operation Period, conform to the maintenance requirements set forth in this Schedule-K (the "Maintenance Requirements").
- 1.2 The Concessionaire shall repair or rectify any defect or deficiency set forth in Paragraph 2 of this Schedule-K within the time limit specified therein and any failure in this behalf shall constitute a breach of the Agreement. Upon occurrence of any breach hereunder, the Authority shall be entitled to recover Damages as set forth in Clause 17.8 of the Agreement, without prejudice to the rights of the Authority under the Agreement, including Termination thereof.

2. Repair/rectification of defects and deficiencies

- 2.1 The obligations of the Concessionaire in respect of Maintenance Requirements shall include repair and rectification of the defects and deficiencies specified in Annex - I of this Schedule - K within the time limit set forth therein.
- 2.2 The Concessionaire shall at all times maintain an adequate inventory of spares and consumables to meet the Maintenance Requirements.

3 Other defects and deficiencies

- 3.1 In respect of any defect or deficiency not specified in Annex - I of this Schedule-K, the Concessionaire shall undertake repair or rectification in accordance with Good Industry Practice and within the time limit specified by the Independent Engineer.
- 3.2 In respect of any defect or deficiency not specified in Annex - I of this Schedule-K, the Independent Engineer may, in conformity with Good Industry Practice, specify the permissible limit of deviation or deterioration with reference to the Specifications and Standards, and any deviation or deterioration beyond the permissible limit shall be repaired or rectified by the Concessionaire in accordance with Good Industry Practice and within the time limit specified by the Independent Engineer.

4 Extension of time limit

Notwithstanding anything to the contrary specified in this Schedule-K, if the nature and extent of any defect or deficiency justifies more time for its repair or rectification than the time specified herein, the Concessionaire shall be entitled to additional time in conformity the Good Industry Practice. Such additional time shall



be determined by the Independent Engineer and conveyed to the Concessionaire and the Authority with reasons thereof.

5 Emergency repairs/restoration

Notwithstanding anything to the contrary contained in this Schedule-K, if any defect, deficiency or deterioration in the Project poses a hazard to safety or risk of damage to property, the Concessionaire shall promptly take all reasonable measures for eliminating or minimizing such danger.

6 Daily Inspection by the Concessionaire

The Concessionaire shall, through its engineer, undertake a daily visual inspection of the Project and maintain a record thereof in a register to be kept in such form and manner as the Independent Engineer may specify. Such record shall be kept in safe custody of the Concessionaire and shall be open to inspection by the Authority and the Independent Engineer at any time during office hours.

7 Divestment Requirements

All defects and deficiencies specified in this Schedule-K shall be repaired and rectified by the Concessionaire so that the Project conforms to the Maintenance Requirements on the Transfer Date.

8 Display of Schedule - K

The Concessionaire shall display copy of this Schedule –K at the site along with the complaint register stipulated in article 40.



ANNEX – I

(Schedule-K)

Repair/Rectification of Defects and Deficiencies

The Concessionaire shall repair and rectify the defects and deficiencies specified in this Annex-I of Schedule-K within the time limit set forth herein.

ROADS

(a)

S.No.	Nature of defect or deficiency	Time limit for Repair/rectification
Carriageway and paved shoulders		
(i)	Breach or blockade	Temporary restoration of traffic within 24 hours; permanent restoration within 15 days
(ii)	Roughness value exceeding 2,750 mm in a stretch of 1 km (as measured by a standardized rough meter/bump integrator)	180 days
(iii)	Pot holes	48 hours
(iv)	Cracking in more than 5% of road surface in a stretch of 1 km	30 days
(v)	Rutting exceeding 10 mm in more than 2% of road surface in a stretch of 1 km (measured with 3 m straight edge)	30 days
(vi)	Bleeding/skidding	7 days
(vii)	Raveling/Stripping of bitumen surface exceeding 10 Sq m	15 days
(viii)	Damage to pavement edges exceeding 100 mm	15 days
(ix)	Removal of debris	6 hours
Hard/earth shoulders, side slopes, drains and culverts		
(i)	Variation by more than 2% in the prescribed slope of camber/cross fall	30 days
(ii)	Edge drop at shoulders exceeding 40 mm	7 days
(iii)	Variation by more than 15% in the prescribed side (embankment) slopes	30 days
(iv)	Rain cuts/gullies in slope	7 days
(v)	Damage to or silting of culverts and side drains during and immediately preceding the rainy season	7 days
(vi)	Desalting of drains in urban/semi-urban areas	48 hours
Road side furniture including road signs and pavement marking		
(i)	Damage to shape or position; Poor visibility or loss of retro-reflectivity	48 hours
Street lighting and telecom (ATMS)		
(i)	Any major failure of the system	24 hours



PUBLIC PRIVATE PARTNERSHIP IN HYBRID ANNUITY PROJECTS

(ii)	Faults and minor failures	8 hours
Trees and plantation		
(i)	Obstruction in a minimum head-room of 5 m above carriageway or obstruction in visibility of road signs	24 hours
(ii)	Deterioration in health of trees and bushes	Timely watering and treatment
(iii)	Replacement of trees and bushes	90 days
(iv)	Removal of vegetation affecting sight line and road structures	15 days
Rest areas		
(i)	Cleaning of toilets	Every 4 hours
(ii)	Defects in electrical, water and sanitary installations	24 hours
Other Project Facilities and Approach roads		
(i)	Damage or deterioration in Approach Roads, [pedestrian facilities, truck lay-bys, bus-bays, bus- shelters, cattle crossings, Traffic Aid Posts, Medical Aid Posts, Rain Water Harvesting/Artificial Recharge Unit and other works]	15 days

BRIDGES

Superstructure of bridges		
(i)	Cracks Temporary measures Permanent measures	Within 48 hours Within 45 days
(ii)	Spalling/scaling	15 days
Foundations of bridges		
(i)	Scouring and/or cavitation	15 days
Piers, abutments, return walls and wing walls		
(i)	Cracks and damages including settlement and tilting	30 days
Bearings (metallic) of bridges		
(i)	Deformation	15 days
Joints in bridges		
(i)	Loosening and malfunctioning of joints	15 days
Other items relating to bridges		
(i)	Deforming of pads in elastomeric bearings	7 days
(ii)	Gathering of dirt in bearings and joints or clogging of spouts, weep holes and vent-holes	3 days
(iii)	Damage or deterioration in parapets and handrails	3 days
(iv)	Rain-cuts or erosion of banks of the side slopes of approaches	15 days
(v)	Damage to wearing coat	15days
(vi)	Damage or deterioration in approach slabs, pitching, apron, toes, floor or guide bunds	30 days
(vii)	Growth of vegetation affecting the structure or obstructing the waterway	15 days



SCHEDULE - L

(See Clause 18.1.1)

SAFETY REQUIREMENTS

Guiding principles

- 1.1 Safety Requirements aim at reduction in injuries, loss of life and damage to property resulting from accidents on or about the Project, irrespective of the person(s) at fault.
- 1.2 Users of the Project include motorised and non-motorized vehicles as well as pedestrians and animals involved in, or associated with accidents. Vulnerable Road Users (VRU) include pedestrians as well as riders of motorized two-wheelers, bicycles and other vehicles which do not provide adequate occupant protection.
- 1.3 Safety Requirements apply to all phases of construction, operation and maintenance with emphasis on identification of factors associated with accidents, consideration of the same, and implementation of appropriate remedial measures.
- 1.4 Safety Requirements include measures associated with traffic management and regulation such as road signs, pavement marking, traffic control devices, roadside furniture, highway design elements, enforcement and emergency response.

2 Obligations of the Concessionaire

The Concessionaire shall abide by the following insofar as they relate to safety of the Users:

- (a) Applicable Laws and Applicable Permits;
- (b) Manual for Safety in Road Design, issued by MoRTH;
- (c) Relevant Standards/Guidelines of IRC relating to safety, road geometries, bridges, culverts, road signs, pavement marking and roadside furniture;
- (d) Provisions of this Agreement; and
- (e) Good Industry Practice.

3 Appointment of Safety Consultant

For carrying out safety audit of the Project under and in accordance with this Schedule-L, the Authority shall appoint from time to time, one or more qualified firms or organisations as its consultants (the "Safety Consultant"). The Safety Consultant shall employ a team comprising, without limitation, one road safety expert and one traffic planner to undertake safety audit of the Project.

4 Safety measures during Development Period

- 4.1 No later than 90 (ninety) days from the date of this Agreement, the Authority shall appoint a Safety Consultant for carrying out safety audit at the design stage of the Project. The Safety Consultant shall collect data on all fatal crashes and other road



accidents which occurred on the Project in the preceding two years by obtaining copies of the relevant First Information Reports (FIRs) from the police stations having jurisdiction. The information contained in such FIRs shall be summarised in the form prescribed by the Authority for this purpose and the data shall be analysed for the type of victims killed or injured, impacting vehicles, location of accidents and other relevant factors.

- 4.2 The Concessionaire shall provide to the Safety Consultant, in four copies, the relevant drawings containing the design details that have a bearing on safety of Users (the "Safety Drawings"). Such design details shall include horizontal and vertical alignments; sightlines; layouts of intersections; interchanges; road cross-section; bridges and culverts; side drains; provision for parked vehicles, slow moving vehicles (tractors, bullock carts, bicycles) and pedestrians; bus bays; truck lay-bys; and other incidental or consequential information. The Safety Consultant shall review the design details and forward 3 (three) copies of the Safety Drawings with its recommendations, if any, to the Independent Engineer who shall record its comments, if any, and forward one copy each to the Authority and the Concessionaire.
- 4.3 The accident data and the design details shall be compiled, analysed and used by the Safety Consultant for evolving a package of recommendations consisting of safety related measures for the Project. The safety audit shall be completed in a period of three months and a report thereof (the "Safety Report") shall be submitted to the Authority, in 5 (five) copies. One copy each of the Safety Report shall be forwarded by the Authority to the Concessionaire and the Independent Engineer forthwith.
- 4.4 The Concessionaire shall endeavor to incorporate the recommendations of the Safety Report in the design of the Project, as may reasonably be required in accordance with Applicable Laws, Applicable Permits, Manuals and Guidelines of the Authority, Specifications and Standards, and Good Industry Practice. If the Concessionaire does not agree with any or all of such recommendations, it shall state the reasons thereof and convey them to the Authority forthwith. In the event that any or all of the works and services recommended in the Safety Report fall beyond the scope of Schedule-B, Schedule-C or Schedule-D, the Concessionaire shall make a report thereon and seek the instructions of the Authority for funding such works in accordance with the provisions of Article 18.
- 4.5 Without prejudice to the provisions of Paragraph 4.4, the Concessionaire and the Independent Engineer shall, within 15 (fifteen) days of receiving the Safety Report, send their respective comments thereon to the Authority, and no later than 15 (fifteen) days of receiving such comments, the Authority shall review the same along with the Safety Report and by notice direct the Concessionaire to carry out any or all of the recommendations contained therein with such modifications as the Authority may specify; provided that any works or services required to be undertaken hereunder shall be governed by the provisions of Article 18.

5 Safety measures during Construction Period



- 5.1 A Safety Consultant shall be appointed by the Authority, no later than 4 (four) months prior to the expected COD, for carrying out a safety audit of the completed Construction Works.
- 5.2 The Safety Consultant shall collect and analyses the accident data for the preceding two years in the manner specified in Paragraph 4.1 of this Schedule- L. It shall study the Safety Report for the Development Period and inspect the Project to assess the adequacy of safety measures. The Safety Consultant shall complete the safety audit within a period of 4 (four) months and submit a Safety Report recommending a package of additional road safety measures, if any, that are considered essential for reducing accident hazards on the Project. Such recommendations shall be processed, mutatis mutandis, and acted upon in the manner set forth in Paragraphs 4.3, 4.4 and 4.5 of this Schedule-L.
- 5.3 The Concessionaire shall make adequate arrangements during the Construction Period for the safety of workers and road Users in accordance with the guidelines of IRC for safety in construction zones, and notify the Authority and the Independent Engineer about such arrangements.

6 Safety measures during Operation Period

- 6.1 The Concessionaire shall develop, implement and administer a surveillance and safety program for Users, including correction of safety violations and deficiencies and all other actions necessary to provide a safe environment in accordance with this Agreement.
- 6.2 The Concessionaire shall establish a Highway Safety Management Unit (the "HSMU") to be functional on and after COD, and designate one of its officers to be in-charge of the HSMU. Such officer shall have specialist knowledge and training in road safety and traffic engineering by having attended a course conducted by a reputed organization on the subject.
- 6.3 The Concessionaire shall keep a copy of every FIR recorded by the Police with respect to any accident occurring on the Project. In addition, the Concessionaire shall also collect data for all cases of accidents not recorded by the Police but where a vehicle rolled over or had to be towed away. The information so collected shall be summarized in the form prescribed by the Authority for this purpose. The Concessionaire shall also record the exact location of each accident on a road map. The aforesaid data shall be submitted to the Authority at the conclusion of every quarter and to the Safety Consultant as and when appointed.
- 6.4 The Concessionaire shall submit to the Authority before the 31st(thirty first) May of each year, an annual report (in ten copies) containing, without limitation, a detailed listing and analysis of all accidents of the preceding Accounting Year and the measures taken by the Concessionaire pursuant to the provisions of Paragraph 6.1 of this Schedule-L for averting or minimizing such accidents in future.
- 6.5 Once in every Accounting Year, a safety audit shall be carried out by the Safety Consultant to be appointed by the Authority. It shall review and analyses the annual report and accident data of the preceding year, and undertake an inspection of the



Project. The Safety Consultant shall complete the safety audit within a period of 1 (one) month and submit a Safety Report recommending specific improvements, if any, required to be made to the road, bridges, culverts, markings, signs, road furniture and Project Facilities, including cattle crossings and pedestrian crossings. Such recommendations shall be processed, mutatis mutandis, and acted upon in the manner set forth in Paragraphs 4.3, 4.4 and 4.5 of this Schedule-L.

7 Costs and expenses

Costs and expenses incurred in connection with the Safety Requirements set forth herein, including the provisions of Paragraph 2 of this Schedule-L, shall be met in accordance with Article 18, and in particular, the remuneration of the Safety Consultant, safety audit, and costs incidental thereto, shall be met by the Concessionaire.

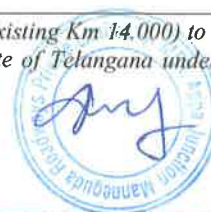

SCHEDULE - M

(See Clause 21.1)

SELECTION OF INDEPENDENT ENGINEER

1 Selection of Independent Engineer

- 1.1 The provisions of the Model Request for Proposals for Selection of Technical Consultants, issued by the Ministry of Finance, GOI vide OM 24(23)/PF-II/ 2008 dated 21 May 2009, or any substitute thereof shall apply for selection of an experienced firm to discharge the functions and duties of an Independent Engineer. Provided, however, that no entity which is owned or controlled by the Authority shall be eligible for appointment as the Independent Engineer hereunder.
- 1.2 In the event of termination of an Independent Engineer appointed in accordance with the provisions of Paragraph 1.1, the Authority shall appoint another firm of Technical Consultants forthwith or may engage a government-owned entity in accordance with the provisions of Paragraph 5 of this Schedule-M.
- 1.3 The Concessionaire may, in its discretion, nominate a representative to participate in the process of selection to be undertaken by the Authority under this Schedule-M.

2 Terms of Reference

The Terms of Reference for the Independent Engineer shall substantially conform to Schedule-N.

3 Fee and expenses

- 3.1 In determining the nature and quantum of duties and services to be performed by the Independent Engineer during the Development Period and Construction Period, the Authority shall endeavor that payments to the Independent Engineer on account of fee and expenses do not exceed 3% (three per cent) of the Bid Project Cost. Payments not exceeding such 3% (three per cent) shall be borne equally by the Authority and the Concessionaire in accordance with the provisions of this Agreement and any payments in excess thereof shall be borne entirely by the Authority.
- 3.2 The nature and quantum of duties and services to be performed by the Independent Engineer during the Operation Period shall be determined by the Authority in conformity with the provisions of this Agreement and with due regard for economy in expenditure. All payments made to the Independent Engineer on account of fee and expenses during the Operation Period shall be borne equally by the Authority and the Concessionaire.

4 Selection every three years

No later than 3 (three) years from the date of appointment of Independent Engineer pursuant to the provisions of Paragraph 1 of this Schedule-M, and every 3 (three) years thereafter, the Authority shall engage another firm in accordance with the criteria set forth in this Schedule-M.

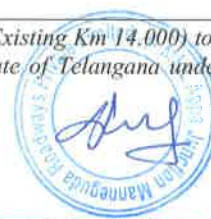

5 Appointment of government entity as Independent Engineer

Notwithstanding anything to the contrary contained in this Schedule, the Authority may in its discretion appoint a government-owned entity as the Independent Engineer; provided that such entity shall be a body corporate having as one of its primary function the provision of consulting, advisory and supervisory services for engineering projects; provided further that a government- owned entity which is owned or controlled by the Authority shall not be eligible for appointment as Independent Engineer.



SCHEDULE - N

(See Clause 21.2.1)

TERMS OF REFERENCE FOR INDEPENDENT ENGINEER

1 Scope

These Terms of Reference for the Independent Engineer (the "TOR") are being specified pursuant to the Concession Agreement dated (the "Agreement"), which has been entered into between the Authority and the "Concessionaire") for **Four laning of NH-163 from Hyderabad (ORR Appa Junction) (Design Km 14.000/Existing Km 14.000) to Manneguda (Design Km 60.405/Existing Km 59.500) (Design Length = 46.405 Km) in the State of Telangana under NH(O)** on design, build, operate and transfer (the "DBOT Annuity or Hybrid Annuity") basis, and a copy of which is annexed hereto and marked as Annex-A to form part of this TOR.

2 Definitions and interpretation

2.1 The words and expressions beginning with or in capital letters used in this TOR and not defined herein but defined in the Agreement shall have, unless repugnant to the context, the meaning respectively assigned to them in the Agreement.

2.2 References to Articles, Clauses and Schedules in this TOR shall, except where the context otherwise requires, be deemed to be references to the Articles, Clauses and Schedules of the Agreement, and references to Paragraphs shall be deemed to be references to Paragraphs of this TOR.

2.3 The rules of interpretation stated in Clauses 1.2, 1.3 and 1.4 of the Agreement shall apply, mutatis mutandis, to this TOR.

3.1 The role and functions of the Independent Engineer shall include the following:

- (i) review of the Drawings and Documents as set forth in Paragraph 4;
- (ii) Review, inspection and monitoring of Construction Works as set forth in Paragraph 5; conducting Tests on completion of construction and issuing Completion/ Provisional Certificate as set forth in Paragraph 5
- (iv) Review, inspection and monitoring of O&M as set forth in Paragraph 6;
- (v) review, inspection and monitoring of Divestment Requirements as set forth in Paragraph 7;
- (vi) determining, as required under the Agreement, the costs of any works or services and/or their reasonableness;
- (vii) determining, as required under the Agreement, the period or any extension thereof, for performing any duty or obligation;
- (viii) Assisting the Parties in resolution of Disputes as set forth in Paragraph 9; and
- (ix) Undertaking all other duties and functions in accordance with the Agreement.



3.2 The Independent Engineer shall discharge its duties in a fair, impartial and efficient manner, consistent with the highest standards of professional integrity and Good Industry Practice.

4 Development Period

4.1 During the Development Period, the Independent Engineer shall undertake a detailed review of the Drawings to be furnished by the Concessionaire along with supporting data, including the geo-technical and hydrological investigations, characteristics of materials from borrow areas and quarry sites, topographical surveys and traffic surveys. The Independent Engineer shall complete such review and send its comments/observations to the Authority and the Concessionaire within 15 (fifteen) days of receipt of such Drawings. In particular, such comments shall specify the conformity or otherwise of such Drawings with the Scope of the Project and Specifications and Standards.

4.2 The Independent Engineer shall review any modified Drawings or supporting Documents sent to it by the Concessionaire and furnish its comments within 7 (seven) days of receiving such Drawings or Documents.

4.3 The Independent Engineer shall review the Drawings sent to it by the Safety Consultant in accordance with Schedule-L and furnish its comments thereon to the Authority and the Concessionaire within 7 (seven) days of receiving such Drawings. The Independent Engineer shall also review the Safety Report and furnish its comments thereon to the Authority within 15 (fifteen) days of receiving such report.

4.4 The Independent Engineer shall review the detailed design, construction methodology, quality assurance procedures and the procurement, engineering and construction time schedule sent to it by the Concessionaire and furnish its comments within 15 (fifteen) days of receipt thereof.

4.5 Upon reference by the Authority, the Independent Engineer shall review and; comment on the EPC Contract or any other contract for construction, operation and maintenance of the Project, and furnish its comments within 7 (seven) days from receipt of such reference from the Authority.

5 Construction Period

5.1 In respect of the Drawings, Documents and Safety Report received by the Independent Engineer for its review and comments during the Construction Period, the provisions of Paragraph 4 shall apply, mutatis mutandis.

5.2 The Independent Engineer shall review the monthly progress report furnished by the Concessionaire and send its comments thereon to the Authority and the Concessionaire within 7 (seven) days of receipt of such report.

5.3 The Independent Engineer shall inspect the Construction Works and the Project once every month, preferably after receipt of the monthly progress report from the Concessionaire, but before the 20th (twentieth) day of each month in any case, and make out a report of such inspection (the "Inspection Report") setting forth an overview



of the status, progress, quality and safety of construction, including the work methodology adopted, the materials used and their sources, and conformity of Construction Works with the Scope of the Project and the Specifications and Standards. In a separate section of the Inspection Report, the Independent Engineer shall describe in reasonable detail the lapses, defects or deficiencies observed by it in the construction of the Project. The Inspection Report shall also contain a review of the maintenance of the existing lanes in conformity with the provisions of the Agreement. The Independent Engineer shall send a copy of its Inspection Report to the Authority and the Concessionaire within 7 (seven) days of the inspection.

- 5.4 The Independent Engineer may inspect the Project more than once in a month if any lapses, defects or deficiencies require such inspections.
- 5.5 For determining that the Construction Works conform to Specifications and Standards, the Independent Engineer shall require the Concessionaire to carry out, or cause to be carried out, tests on a sample basis, to be specified by the Independent Engineer in accordance with Good Industry Practice for quality assurance. For purposes of this Paragraph 5.5, the tests specified in the IRC Special Publication-11 (Handbook of Quality Control for Construction of Roads and Runways) and the Specifications for Road and Bridge Works issued by the Authority (the "Quality Control Manuals") or any modification/substitution thereof shall be deemed to be tests conforming to Good Industry Practice for quality assurance. The Independent Engineer shall issue necessary directions to the Concessionaire for ensuring that the tests are conducted in a fair and efficient manner, and shall monitor and review the results thereof.
- 5.6 The sample size of the tests, to be specified by the Independent Engineer under Paragraph 5.5, shall comprise 10% (ten per cent) of the quantity or number of tests prescribed for each category or type of tests in the Quality Control Manuals; provided that the Independent Engineer may, for reasons to be recorded in writing, increase the aforesaid sample size by up to 10% (ten per cent) for certain categories or types of tests.
- 5.7 The timing of tests referred to in Paragraph 5.5, and the criteria for acceptance/rejection of their results shall be determined by the Independent Engineer in accordance with the Quality Control Manuals. The tests shall be undertaken on a random sample basis and shall be in addition to, and independent of, the tests that may be carried out by the Concessionaire for its own quality assurance in accordance with Good Industry Practice.
- 5.8 In the event that the Concessionaire carries out any remedial works for removal or rectification of any defects or deficiencies, the Independent Engineer shall require the Concessionaire to carry out, or cause to be carried out, tests to determine that such remedial works have brought the Construction Works into conformity with the Specifications and Standards, and the provisions of this Paragraph 5 shall apply to such tests.
- 5.9 In the event that the Concessionaire fails to achieve any of the Project Milestones, the Independent Engineer shall undertake a review of the progress of construction and identify potential delays, if any. If the Independent Engineer shall determine that



completion of the Project is not feasible within the time specified in the Agreement, it shall require the Concessionaire to indicate within 15 (fifteen) days the steps proposed to be taken to expedite progress, and the period within which COD shall be achieved. Upon receipt of a report from the Concessionaire, the Independent Engineer shall review the same and send its comments to the Authority and the Concessionaire forthwith.

- 5.10 If at any time during the Construction Period, the Independent Engineer determines that the Concessionaire has not made adequate arrangements for the safety of workers and Users in the zone of construction or that any work is being carried out in a manner that threatens the safety of the workers and the Users, it shall make a recommendation to the Authority forthwith, identifying the whole or part of the Construction Works that should be suspended for ensuring safety in respect thereof.
- 5.11 In the event that the Concessionaire carries out any remedial measures to secure the safety of suspended works and Users, it may, by notice in writing, require the Independent Engineer to inspect such works, and within 3 (three) days of receiving such notice, the Independent Engineer shall inspect the suspended works and make a report to the Authority forthwith, recommending whether or not such suspension may be revoked by the Authority.
- 5.12 If suspension of Construction Works is for reasons not attributable to the Concessionaire, the Independent Engineer shall determine the extension of dates set forth in the Project Completion Schedule, to which the Concessionaire is reasonably entitled, and shall notify the Authority and the Concessionaire of the same.
- 5.13 The Independent Engineer shall carry out, or cause to be carried out, all the Tests specified in Schedule-I and issue a Completion Certificate or Provisional Certificate, as the case may be. For carrying out its functions under this Paragraph 5.13 and all matters incidental thereto, the Independent Engineer shall act under and in accordance with the provisions of Article 14 and Schedule-I.
- 5.14 Upon reference from the Authority, the Independent Engineer shall make a fair and reasonable assessment of the costs of providing information, works and services as set forth in Article 16 and certify the reasonableness of such costs for payment by the Authority to the Concessionaire.
- 5.15 The Independent Engineer shall aid and advise the Concessionaire in preparing the Maintenance Manual.
- 5.16 Upon reference from the Authority, the Independent Engineer shall undertake the assessment of cost of civil works, as per applicable schedule of rates, for the reduction of Scope of work as provided in Clause 16.6.1 of the Concession Agreement.

6 Operation Period

- 6.1 In respect of the Drawings, Documents and Safety Report received by the Independent Engineer for its review and comments during the Operation Period, the provisions of Paragraph 4 shall apply, mutatis mutandis.



PUBLIC PRIVATE PARTNERSHIP IN HYBRID ANNUITY PROJECTS

- 6.2 The Independent Engineer shall review the annual Maintenance Program furnished by the Concessionaire and send its comments thereon to the Authority and the Concessionaire within 15 (fifteen) days of receipt of the Maintenance Program.
- 6.3 The Independent Engineer shall review the monthly status report furnished by the Concessionaire and send its comments thereon to the Authority and the Concessionaire within 7 (seven) days of receipt of such report.
- 6.4 The Independent Engineer shall inspect the Project once every month, preferably after receipt of the monthly status report from the Concessionaire, but before the 20th (twentieth) day of each month in any case, and make out an O&M Inspection Report setting forth an overview of the status, quality and safety of O&M including its conformity with the Maintenance Requirements and Safety Requirements. In a separate section of the O&M Inspection Report, the Independent Engineer shall describe in reasonable detail the lapses, defects or deficiencies observed by it in O&M of the Project. The Independent Engineer shall send a copy of its O&M Inspection Report to the Authority and the Concessionaire within 7 (seven) days of the inspection.
- 6.5 The Independent Engineer may inspect the Project more than once in a month, if any lapses, defects or deficiencies require such inspections.
- 6.6 The Independent Engineer shall in its O&M Inspection Report specify the tests, if any, that the Concessionaire shall carry out, or cause to be carried out, for the purpose of determining that the Project is in conformity with the Maintenance Requirements. It shall monitor and review the results of such tests and the remedial measures, if any, taken by the Concessionaire in this behalf.
- 6.7 In respect of any defect or deficiency referred to in Paragraph 3 of Schedule- K, the Independent Engineer shall, in conformity with Good Industry Practice, specify the permissible limit of deviation or deterioration with reference to the Specifications and Standards and shall also specify the time limit for repair or rectification of any deviation or deterioration beyond the permissible limit.
- 6.8 The Independent Engineer shall determine if any delay has occurred in completion of repair or remedial works in accordance with the Agreement, and shall also determine the Damages, if any, payable by the Concessionaire to the Authority for such delay.
- 6.9 The Independent Engineer shall examine the request of the Concessionaire for closure of any lane(s) of the carriageway for undertaking maintenance/repair thereof, keeping in view the need to minimize disruption in traffic and the time required for completing such maintenance/repair in accordance with Good Industry Practice. It shall grant permission with such modifications, as it may deem necessary, within 3 (three) days of receiving a request from the Concessionaire. Upon expiry of the permitted period of closure, the Independent Engineer shall monitor the re-opening of such lane(s), and in case of delay, determine the Damages payable by the Concessionaire to the Authority under Clause 17.7.
- 6.10 The Independent Engineer shall monitor and review the curing of defects and deficiencies by the Concessionaire as set forth in Clause 19.4.



6.11 In the event that the Concessionaire notifies the Independent Engineer of any modifications that it proposes to make to the Project, the Independent Engineer shall review the same and send its comments to the Authority and the Concessionaire within 15 (fifteen) days of receiving the proposal.

6.12 The Independent Engineer shall undertake traffic sampling, as and when required by the Authority, under and in accordance with the provisions of this Agreement.

7 Termination

7.1 At any time, not earlier than 90 (ninety) days prior to Termination but not later than 15 (fifteen) days prior to such Termination, the Independent Engineer shall, in the presence of a representative of the Concessionaire, inspect the Project for determining compliance by the Concessionaire with the Divestment Requirements set forth in Clause 32.1 and, if required, cause tests to be carried out at the Concessionaire's cost for determining such compliance. If the Independent Engineer determines that the status of the Project is such that its repair and rectification would require a larger amount than the sum set forth in Clause 33.2, it shall recommend retention of the required amount in the Escrow Account and the period of retention thereof.

7.2 The Independent Engineer shall inspect the Project once in every 15 (fifteen) days during a period of 90 (ninety) days after Termination for determining the liability of the Concessionaire under Article 33, in respect of the defects or deficiencies specified therein. If any such defect or deficiency is found by the Independent Engineer, it shall make a report in reasonable detail and send it forthwith to the Authority and the Concessionaire.

8 Determination of costs and time

8.1 The Independent Engineer shall determine the costs, and/or their reasonableness, that are required to be determined by it under the Agreement.

8.2 The Independent Engineer shall determine the period, or any extension thereof, that is required to be determined by it under the Agreement.

9 Assistance in Dispute resolution

9.1 When called upon by either Party in the event of any Dispute, the Independent Engineer shall mediate and assist the Parties in arriving at an amicable settlement.

9.2 In the event of any disagreement between the Parties regarding the meaning, scope and nature of Good Industry Practice, as set forth in any provision of the Agreement, the Independent Engineer shall specify such meaning, scope and nature by issuing a reasoned written statement relying on good industry practice and authentic literature.

10 Other duties and functions

The Independent Engineer shall perform all other duties and functions specified in the Agreement.

11 Miscellaneous

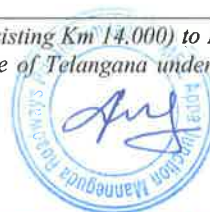

- 11.1 The Independent Engineer shall notify its programmer of inspection to the Authority and to the Concessionaire, who may, in their discretion, depute their respective representatives to be present during the inspection.
- 11.2 A copy of all communications, comments, instructions, Drawings or Documents sent by the Independent Engineer to the Concessionaire pursuant to this TOR, and a copy of all the test results with comments of the Independent Engineer thereon shall be furnished by the Independent Engineer to the Authority forthwith.
- 11.3 The Independent Engineer shall obtain, and the Concessionaire shall furnish in 2(two)..... Copies thereof, all communications and reports required to be submitted, under this Agreement, by the Concessionaire to the Independent Engineer, whereupon the Independent Engineer shall send 1 (one) of the copies to the Authority along with its comments thereon.
- 11.4 The Independent Engineer shall retain at least one copy each of all Drawings and Documents received by it, including 'as-built' Drawings, and keep them in its safe custody.
- 11.5 Upon completion of its assignment hereunder, the Independent Engineer shall duly classify and list all Drawings, Documents, results of tests and other relevant records, and hand them over to the Authority or such other person as the Authority may specify, and obtain written receipt thereof. Two copies of the said documents shall also be furnished in their editable digital format or in such other medium or manner as may be acceptable to the Authority.
- 11.6 Wherever no period has been specified for delivery of services by the Independent Engineer, the Independent Engineer shall act with the efficiency and urgency necessary for discharging its functions in accordance with Good Industry Practice.



SCHEDULE -O

(See Clause 25.1.2)

ESCROW AGREEMENT

THIS ESCROW AGREEMENT is entered into on this the day of 20__ AMONGST

- 1Limited, a company incorporated under the provisions of the Companies Act, 2013 and having its registered office at..... (hereinafter referred to as the "Concessionaire" which expression shall, unless repugnant to the context or meaning thereof, include its successors, permitted assigns and substitutes);
- 2(insert name and particulars of Lenders' Representative) and having its registered office at..... acting for and on behalf of the Senior Lenders as their duly authorized agent with regard to matters arising out of or in relation to this Agreement (hereinafter referred to as the "Lenders' Representative" which expression shall, unless repugnant to the context or meaning thereof, include its successors and substitutes);
- 3(insert name and particulars of the Escrow Bank) and having its registered office at..... (hereinafter referred to as the "Escrow Bank" which expression shall, unless repugnant to the context or meaning thereof, include its successors and substitutes); and
- 4 The NATIONAL HIGHWAYS AUTHORITY OF INDIA, established under the National Highways Authority of India Act 1988, represented by its Chairman and having its principal offices at G-5&6, Sector-10, Dwarka, New Delhi-110075 (hereinafter referred to as the "Authority" which expression shall, unless repugnant to the context or meaning thereof, include its administrators, successors and assigns).

WHEREAS:

- (A) The Authority has entered into a Concession Agreement dated with the Concessionaire (the "Concession Agreement") for **Four laning of NH-163 from Hyderabad (ORR Appa Junction) (Design Km 14.000/Existing Km 14.000) to Manneguda (Design Km 60.405/Existing Km 59.500) (Design Length = 46.405 Km) in the State of Telangana under NH(O) Project** (the "Project") on design, build, operate and transfer (the "DBOT Annuity or Hybrid Annuity") basis, and a copy of which is annexed hereto and marked as Annex-A to form part of this Agreement.
- (B) Senior Lenders have agreed to finance the Project in accordance with the terms and conditions set forth in the Financing Agreements.
- (C) The Concession Agreement requires the Concessionaire to establish an Escrow Account, inter alia, on the terms and conditions stated therein.

NOW, THEREFORE, in consideration of the foregoing and the respective covenants and agreements set forth in this Agreement, the receipt and sufficiency of which is hereby acknowledged, and intending to be legally bound hereby, the Parties agree as follows:

*Four laning of NH-163 from Hyderabad (ORR Appa Junction) (Design Km 14.000/Existing Km 14.000) to Manneguda (Design Km 60.405/Existing Km 59.500) (Design Length = 46.405 Km) in the State of Telangana under NH(O) on Hybrid Annuity Mode*Page 194



261

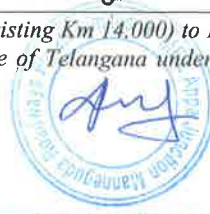

1 DEFINITIONS AND INTERPRETATION

1.1 Definitions

In this Agreement, the following words and expressions shall, unless repugnant to the context or meaning thereof, have the meaning hereinafter respectively assigned to them:

“Agreement” means this Escrow Agreement and any amendment thereto made in accordance with the provisions contained herein;

“Concession Agreement” means the Concession Agreement referred to in Recital (A) above and annexed hereto as Annex-A, and shall include all of its Recitals and Schedules and any amendments made thereto in accordance with the provisions contained in this behalf therein;

“Cure Period” means the period specified in this Agreement for curing any breach or default of any provision of this Agreement by the Concessionaire, and shall commence from the date on which a notice is delivered by the Authority or the Lenders’ Representative, as the case may be, to the Concessionaire asking the latter to cure the breach or default specified in such notice;

“Escrow Account” means an escrow account established in terms of and under this Agreement, and shall include the Sub-Accounts;

“Escrow Default” shall have the meaning ascribed thereto in Clause 6.1;

“Lenders’ Representative” means the person referred to as the Lenders’ Representative in the foregoing Recitals;

“Parties” means the parties to this Agreement collectively and **“Party”** shall mean any of the Parties to this Agreement individually;

“Payment Date” means, in relation to any payment specified in Clause 4.1, the date(s) specified for such payment; and

“Sub-Accounts” means the respective sub-accounts of the Escrow Account, into which the monies specified in Clause 4.1 would be credited every month and paid out if due, and if not due in a month then appropriated proportionately in such month and retained in the respective sub-accounts and paid out therefrom on the Payment Date(s).

1.2 Interpretation

1.2.1 References to Lenders’ Representative shall, unless repugnant to the context or meaning thereof, mean references to the Lenders’ Representative, acting for and on behalf of Senior Lenders.

1.2.2 The words and expressions beginning with capital letters and defined in this Agreement shall have the meaning ascribed thereto herein, and the words and expressions used in this Agreement and not defined herein but defined in the Concession Agreement shall, unless repugnant to the context, have the meaning ascribed thereto in the Concession Agreement.



1.2.3 References to Clauses are, unless stated otherwise, references to Clauses of this Agreement.

1.2.4 The rules of interpretation stated in Clauses 1.2, 1.3 and 1.4 of the Concession Agreement shall apply, mutatis mutandis, to this Agreement.

2 ESCROW ACCOUNT

2.1 Escrow Bank to act as trustee

2.1.1 The Concessionaire hereby appoints the Escrow Bank to act as trustee for the Authority, the Lenders' Representative and the Concessionaire in connection herewith and authorizes the Escrow Bank to exercise such rights, powers, authorities and discretion as are specifically delegated to the Escrow Bank by the terms hereof together with all such rights, powers, authorities and discretion as are reasonably incidental hereto, and the Escrow Bank accepts such appointment pursuant to the terms hereof.

2.1.2 The Concessionaire hereby declares that all rights, title and interest in and to the Escrow Account shall be vested in the Escrow Bank and held in trust for the Authority, the Lenders' Representative and the Concessionaire, and applied in accordance with the terms of this Agreement. No person other than the Authority, the Lenders' Representative and the Concessionaire shall have any rights hereunder as the beneficiaries of or as third party beneficiaries under this Agreement.

2.2 Acceptance of Escrow Bank

The Escrow Bank hereby agrees to act as such and to accept all payments and other amounts to be delivered to and held by the Escrow Bank pursuant to the provisions of this Agreement. The Escrow Bank shall hold and safeguard the Escrow Account during the term of this Agreement and shall treat the amount in the Escrow Account as monies deposited by the Concessionaire, Senior Lenders or the Authority with the Escrow Bank. In performing its functions and duties under this Agreement, the Escrow Bank shall act in trust for the benefit of, and as agent for, the Authority, the Lenders' Representative and the Concessionaire or their nominees, successors or assigns, in accordance with the provisions of this Agreement.

2.3 Establishment and operation of Escrow Account

2.3.1 Within 30 (thirty) days from the date of this Agreement, and in any case prior to the Appointed Date, the Concessionaire shall open and establish the Escrow Account with the (name of Branch) Branch of the Escrow Bank. The Escrow Account shall be denominated in Rupees.

2.3.2 The Escrow Bank shall maintain the Escrow Account in accordance with the terms of this Agreement and its usual practices and applicable regulations, and pay the maximum rate of interest payable to similar customers on the balance in the said account from time to time.

2.3.3 The Escrow Bank and the Concessionaire shall, after consultation with the Lenders' Representative, agree on the detailed mandates, terms and conditions, and operating procedures for the Escrow Account, but in the event of any conflict or inconsistency



between this Agreement and such mandates, terms and conditions, or procedures, this Agreement shall prevail.

- 2.4 Escrow Bank's fee The Escrow Bank shall be entitled to receive its fee and expenses in an amount, and at such times, as may be agreed between the Escrow Bank and the Concessionaire. For the avoidance of doubt, such fee and expenses shall form part of the O&M Expenses and shall be appropriated from the Escrow Account in accordance with Clause 4.1.
- 2.5 Rights of the Parties Save and except as otherwise provided in the Concession Agreement, the rights of the Authority, the Lenders' Representative and the Concessionaire in the monies held in the Escrow Account are set forth in their entirety in this Agreement and the Authority, the Lenders' Representative and the Concessionaire shall have no other rights against or to the monies in the Escrow Account.
- 2.6 Substitution of the Concessionaire The Parties hereto acknowledge and agree that upon substitution of the Concessionaire with the Nominated Company, pursuant to the Substitution Agreement, it shall be deemed for the purposes of this Agreement that the Nominated Company is a Party hereto and the Nominated Company shall accordingly be deemed to have succeeded to the rights and obligations of the Concessionaire under this Agreement on and with effect from the date of substitution of the Concessionaire with the Nominated Company.

3 DEPOSITS INTO ESCROW ACCOUNT

3.1 Deposits by the Concessionaire

3.1.1 The Concessionaire agrees and undertakes that it shall deposit into and/or credit the Escrow Account with:

- (a) All monies received in relation to the Project from any source, including the Senior Lenders, lenders of Subordinated Debt and the Authority;
- (b) All funds received by the Concessionaire from its shareholders, in any manner or form;
- (c) Any other revenues; rentals, deposits or capital receipts, as the case may be, from or in respect of the Project; and
- (d) All proceeds received pursuant to any insurance claims.

3.1.2 The Concessionaire may at any time make deposits of its other funds into the Escrow Account, provided that the provisions of this Agreement shall apply to such deposits.

3.2 Deposits by the Authority

The Authority agrees and undertakes that, as and when due and payable, it shall deposit into and/or credit the Escrow Account with:

- (a) Grant and any other monies disbursed by the Authority to the Concessionaire;



- (b) All revenues collected by the Authority in exercise of its rights under the Concession Agreement; and
- (c) Termination Payments

Provided that, notwithstanding the provisions of Clause 4.1.1, the Authority shall be entitled to appropriate from the aforesaid amounts, any amounts due and payable to it by the Concessionaire, and the balance remaining shall be deposited into the Escrow Account.

3.3 Deposits by Senior Lenders

The Lenders' Representative agrees, confirms and undertakes that the Senior Lenders shall deposit into and/or credit the Escrow Account with all disbursements made by them in relation to or in respect of the Project; provided that notwithstanding anything to the contrary contained in this Agreement, the Senior Lenders shall be entitled to make direct payments to the EPC Contractor under and in accordance with the express provisions contained in this behalf in the Financing Agreements.

3.4 Interest on deposits

The Escrow Bank agrees and undertakes that all interest accruing on the balances of the Escrow Account shall be credited to the Escrow Account; provided that the Escrow Bank shall be entitled to appropriate therefrom the fee and expenses due to it from the Concessionaire in relation to the Escrow Account and credit the balance remaining to the Escrow Account.

4 WITHDRAWALS FROM ESCROW ACCOUNT

4.1 Withdrawals during Concession Period

4.1.1 At the beginning of every month, or at such shorter intervals as the Lenders' Representative and the Concessionaire may by written instructions determine, the Escrow Bank shall withdraw amounts from the Escrow Account and appropriate them in the following order by depositing such amounts in the relevant Sub-Accounts for making due payments, and if such payments are not due in any month, then retain such monies in such Sub-Accounts and pay out therefrom on the Payment Date(s):

- (a) All taxes due and payable by the Concessionaire for and in respect of the Project;
- (b) Deleted;
- (c) All payments relating to construction of the Project, subject to and in accordance with the conditions, if any, set forth in the Financing Agreements;
- (d) O&M Expenses, subject to the ceiling, if any, set forth in the Financing Agreements;
- (e) O&M Expenses and other costs and expenses incurred by the Authority in accordance with the provisions of the Concession Agreement, and certified by the Authority as due and payable to it;

265



- (f) Any amounts due and payable to the Authority;
- (g) Monthly proportionate provision of Debt Service due in an Accounting Year;
- (h) all payments and Damages certified by the Authority as due and payable to it by the Concessionaire pursuant to the Concession Agreement;
- (i) Monthly proportionate provision of debt service payments due in an Accounting Year in respect of Subordinated Debt;
- (j) any reserve requirements set forth in the Financing Agreements; and
- (k) Balance, if any, in accordance with the instructions of the Concessionaire.

4.1.2 No later than 60 (sixty) days prior to the commencement of each Accounting Year, the Concessionaire shall provide to the Escrow Bank, with prior written approval of the Lenders' Representative, details of the amounts likely to be required for each of the payment obligations set forth in this Clause 4.1; provided that such amounts may be subsequently modified, with prior written approval of the Lenders' Representative, if fresh information received during the course of the year makes such modification necessary.

4.2 Withdrawals upon Termination upon Termination of the Concession Agreement, all amounts standing to the credit of the Escrow Account shall, notwithstanding anything in this Agreement, be appropriated and dealt with in the following order:

- (a) All taxes due and payable by the Concessionaire for and in respect of the Project;
- (b) Deleted;
- (c) 90% (ninety per cent) of Debt Due excluding Subordinated Debt;
- (d) all payments and Damages certified by the Authority as due and payable to it by the Concessionaire pursuant to the Concession Agreement, including any claims in connection with or arising out of Termination;
- (e) Retention and payments arising out of, or in relation to, liability for defects and deficiencies set forth in Article 33 of the Concession Agreement;
- (f) Outstanding Debt Service including the balance of Debt Due;
- (g) Outstanding Subordinated Debt;
- (h) Incurred or accrued O&M Expenses;
- (i) Any other payments required to be made under the Concession Agreement; and
- (j) Balance, if any, in accordance with the instructions of the Concessionaire: Provided that the disbursements specified in Sub-clause (i) of this Clause 4.2 shall be undertaken only after the Vesting Certificate has been issued by the Authority.



4.3 Application of insufficient funds:

Funds in the Escrow Account shall be applied in the serial order of priority set forth in Clauses 4.1 and 4.2, as the case may be. If the funds available are not sufficient to meet all the requirements, the Escrow Bank shall apply such funds in the serial order of priority until exhaustion thereof.

4.4 Application of insurance proceeds

Notwithstanding anything in this Agreement, the proceeds from all insurance claims, except life and injury, shall be deposited into and/or credited to the Escrow Account and utilized for any necessary repair, reconstruction, reinstatement, replacement, improvement, delivery or installation of the Project, and the balance remaining, if any, shall be applied in accordance with the provisions contained in this behalf in the Financing Agreements.

4.5 Withdrawals during Suspension

Notwithstanding anything to the contrary contained in this Agreement, the Authority may exercise all or any of the rights of the Concessionaire during the period of Suspension under Article 30 of the Concession Agreement. Any instructions given by the Authority to the Escrow Bank during such period shall be complied with as if such instructions were given by the Concessionaire under this Agreement and all actions of the Authority hereunder shall be deemed to have been taken for and on behalf of the Concessionaire.

5 OBLIGATIONS OF THE ESCROW BANK

5.1 Segregation of funds

Monies and other property received by the Escrow Bank under this Agreement shall, until used or applied in accordance with this Agreement, be held by the Escrow Bank in trust for the purposes for which they were received, and shall be segregated from other funds and property of the Escrow Bank.

5.2 Notification of balances

7(seven) business days prior to each Payment Date (and for this purpose the Escrow Bank shall be entitled to rely on an affirmation by the Concessionaire and/or the Lenders' Representative as to the relevant Payment Dates), the Escrow Bank shall notify the Lenders' Representative of the balances in the Escrow Account and Sub-Accounts as at the close of business on the immediately preceding business day.

5.3 Communications and notices

In discharge of its duties and obligations hereunder, the Escrow Bank:

- (a) May, in the absence of bad faith or gross negligence on its part, rely as to any matters of fact which might reasonably be expected to be within the knowledge of the Concessionaire upon a certificate signed by or on behalf of the Concessionaire;



- (b) may, in the absence of bad faith or gross negligence on its part, rely upon the authenticity of any communication or document believed by it to be authentic;
- (c) shall, within 5 (five) business days after receipt, deliver a copy to the Lenders' Representative of any notice or document received by it in its capacity as the Escrow Bank from the Concessionaire or any other person hereunder or in connection herewith; and
- (d) shall, within 5 (five) business days after receipt, deliver a copy to the Concessionaire of any notice or document received by it from the Lenders' Representative in connection herewith.

5.4 No set off

The Escrow Bank agrees not to claim or exercise any right of set off, banker's lien or other right or remedy with respect to amounts standing to the credit of the Escrow Account. For the avoidance of doubt, it is hereby acknowledged and agreed by the Escrow Bank that the monies and properties held by the Escrow Bank in the Escrow Account shall not be considered as part of the assets of the Escrow Bank and being trust property, shall in the case of bankruptcy or liquidation of the Escrow Bank, be wholly excluded from the assets of the Escrow Bank in such bankruptcy or liquidation.

5.5 Regulatory approvals

The Escrow Bank shall use its best efforts to procure, and thereafter maintain and comply with, all regulatory approvals required for it to establish and operate the Escrow Account. The Escrow Bank represents and warrants that it is not aware of any reason why such regulatory approvals will not ordinarily be granted to the Escrow Bank.

6 ESCROW DEFAULT

6.1 Escrow Default

6.1.1 Following events shall constitute an event of default by the Concessionaire (an "Escrow Default") unless such event of default has occurred as a result of Force Majeure or any act or omission of the Authority or the Lenders' Representative:

- (a) the Concessionaire commits breach of this Agreement by failing to deposit any receipts into the Escrow Account as provided herein and fails to cure such breach by depositing the same into the Escrow Account within a Cure Period of 5 (five) business days;
- (b) the Concessionaire causes the Escrow Bank to transfer funds to any account of the Concessionaire in breach of the terms of this Agreement and fails to cure such breach by depositing the relevant funds into the Escrow Account or any Sub-Account in which such transfer should have been made, within a Cure Period of 5 (five) business days; or
- (c) the Concessionaire commits or causes any other breach of the provisions of this Agreement and fails to cure the same within a Cure Period of 5 (five) business days.

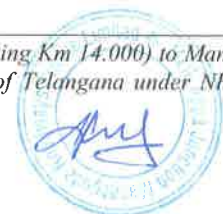

6.1.2 Upon occurrence of an Escrow Default, the consequences thereof shall be dealt with under and in accordance with the provisions of the Concession Agreement.

7 TERMINATION OF ESCROW AGREEMENT

7.1 Duration of the Escrow Agreement

This Agreement shall remain in full force and effect so long as any sum remains to be advanced or is outstanding from the Concessionaire in respect of the debt, guarantee or financial assistance received by it from the Senior Lenders, or any of its obligations to the Authority remain to be discharged, unless terminated earlier by consent of all the Parties or otherwise in accordance with the provisions of this Agreement.

7.2 Substitution of Escrow Bank

The Concessionaire may, by not less than 45 (forty five) days prior notice to the Escrow Bank, the Authority and the Lenders' Representative, terminate this Agreement and appoint a new Escrow Bank, provided that the new Escrow Bank is acceptable to the Lenders' Representative and arrangements are made satisfactory to the Lenders' Representative for transfer of amounts deposited in the Escrow Account to a new Escrow Account established with the successor Escrow Bank.

The termination of this Agreement shall take effect only upon coming into force of an Escrow Agreement with the substitute Escrow Bank.

7.3 Closure of Escrow Account

The Escrow Bank shall, at the request of the Concessionaire and the Lenders' Representative made on or after the payment by the Concessionaire of all outstanding amounts under the Concession Agreement and the Financing Agreements including the payments specified in Clause 4.2, and upon confirmation of receipt of such payments, close the Escrow Account and Sub- Accounts and pay any amount standing to the credit thereof to the Concessionaire. Upon closure of the Escrow Account hereunder, the Escrow Agreement shall be deemed to be terminated.

8 SUPPLEMENTARY ESCROW AGREEMENT

8.1 Supplementary escrow agreement

The Lenders' Representative and the Concessionaire shall be entitled to enter into a supplementary escrow agreement with the Escrow Bank providing, inter alia, for detailed procedures and documentation for withdrawals from Sub- Accounts pursuant to Clause 4.1.1 and for matters not covered under this Agreement such as the rights and obligations of Senior Lenders and lenders of Subordinated Debt, investment of surplus funds, restrictions on withdrawals by the Concessionaire in the event of breach of this Agreement or upon occurrence of an Escrow Default, procedures relating to operation of the Escrow Account and withdrawal therefrom, reporting requirements and any matters incidental thereto; provided that such supplementary escrow agreement shall not contain any provision which is inconsistent with this Agreement and in the event of any conflict or inconsistency between provisions of this Agreement and such supplementary escrow agreement, the provisions of this Agreement shall prevail.



9 INDEMNITIES

9.1 General indemnity

- 9.1.1 The Concessionaire will indemnify, defend and hold the Authority, Escrow Bank and the Senior Lenders, acting through the Lenders' Representative, harmless against any and all proceedings, actions and third party claims for any loss, damage, cost and expense arising out of any breach by the Concessionaire of any of its obligations under this Agreement or on account of failure of the Concessionaire to comply with Applicable Laws and Applicable Permits.
- 9.1.2 The Authority will indemnify, defend and hold the Concessionaire harmless against any and all proceedings, actions and third party claims for any loss, damage, cost and expense arising out of failure of the Authority to fulfil any of its obligations under this Agreement materially and adversely affecting the performance of the Concessionaire's obligations under the Concession Agreement or this Agreement other than any loss, damage, cost and expense arising out of acts done in discharge of their lawful functions by the Authority, its officers, servants and agents.
- 9.1.3 The Escrow Bank will indemnify, defend and hold the Concessionaire harmless against any and all proceedings, actions and third party claims for any loss, damage, cost and expense arising out of failure of the Escrow Bank to fulfil its obligations under this Agreement materially and adversely affecting the performance of the Concessionaire's obligations under the Concession Agreement other than any loss, damage, cost and expense, arising out of acts done in discharge of their lawful functions by the Escrow Bank, its officers, servants and agents.

9.2 Notice and contest of claims

In the event that any Party hereto receives a claim from a third party in respect of which it is entitled to the benefit of an indemnity under Clause 9.1 or in respect of which it is entitled to reimbursement (the "Indemnified Party"), it shall notify the other Party responsible for indemnifying such claim hereunder (the "Indemnifying Party") within 15 (fifteen) days of receipt of the claim and shall not settle or pay the claim without the prior approval of the Indemnifying Party, which approval shall not be unreasonably withheld or delayed. In the event that the Indemnifying Party wishes to contest or dispute the claim, it may conduct the proceedings in the name of the Indemnified Party and shall bear all costs involved in contesting the same. The Indemnified Party shall provide all cooperation and assistance in contesting any claim and shall sign all such writings and documents as the Indemnifying Party may reasonably require.

10 DISPUTE RESOLUTION

10.1 Dispute resolution

- 10.1.1 Any dispute, difference or claim arising out of or in connection with this Agreement, which is not resolved amicably, shall be decided finally by reference to arbitration to a Board of Arbitrators comprising one nominee of each Party to the dispute, and where the number of such nominees is an even number, the nominees shall elect another person to such Board. Such arbitration shall be held in accordance with the Rules of



Arbitration of the International Centre for Alternative Dispute Resolution, New Delhi (the "Rules") or such other rules as may be mutually agreed by the Parties, and shall be subject to the provisions of the Arbitration and Conciliation Act, 1996.

10.1.2 The Arbitrators shall issue a reasoned award and such award shall be final and binding on the Parties. The place of arbitration shall be the capital of the State and the language of arbitration shall be English.

11. MISCELLANEOUS PROVISIONS

11.1 Governing law and jurisdiction

This Agreement shall be construed and interpreted in accordance with and governed by the laws of India, and the courts in the State shall have jurisdiction over all matters arising out of or relating to this Agreement.

11.2 Waiver of sovereign immunity The Authority unconditionally and irrevocably:

- (a) agrees that the execution, delivery and performance by it of this Agreement constitute commercial acts done and performed for commercial purpose;
- (b) agrees that, should any proceedings be brought against it or its assets, property or revenues in any jurisdiction in relation to this Agreement or any transaction contemplated by this Agreement, no immunity (whether by reason of sovereignty or otherwise) from such proceedings shall be claimed by or on behalf of the Authority with respect to its assets;
- (c) waives any right of immunity which it or its assets, property or revenues now has, may acquire in the future or which may be attributed to it in any jurisdiction; and
- (d) consents generally in respect of the enforcement of any judgment or award against it in any such proceedings to the giving of any relief or the issue of any process in any jurisdiction in connection with such proceedings (including the making, enforcement or execution against it or in respect of any assets, property or revenues whatsoever irrespective of their use or intended use of any order or judgment that may be made or given in connection therewith).

11.3 Priority of agreements

In the event of any conflict between the Concession Agreement and this Agreement, the provisions contained in the Concession Agreement shall prevail over this Agreement.

11.4 Alteration of terms

All additions, amendments, modifications and variations to this Agreement shall be effectual and binding only if in writing and signed by the duly authorized representatives of the Parties.

11.5 Waiver

11.5.1 Waiver by any Party of a default by another Party in the observance and performance of any provision of or obligations under this Agreement:



- (a) Shall not operate or be construed as a waiver of any other or subsequent default hereof or of other provisions of or obligations under this Agreement;
- (b) shall not be effective unless it is in writing and executed by a duly authorized representative of the Party; and
- (c) shall not affect the validity or enforceability of this Agreement in any manner.

11.5.2 Neither the failure by any Party to insist on any occasion upon the performance of the terms, conditions and provisions of this Agreement or any obligation thereunder nor time or other indulgence granted by any Party to another Party shall be treated or deemed as waiver of such breach or acceptance of any variation or the relinquishment of any such right hereunder.

11.6 No third party beneficiaries This Agreement is solely for the benefit of the Parties and no other person or entity shall have any rights hereunder.

11.7 Survival

11.7.1 Termination of this Agreement:

- (a) shall not relieve the Parties of any obligations hereunder which expressly or by implication survive termination hereof; and
- (b) except as otherwise provided in any provision of this Agreement expressly limiting the liability of either Party, shall not relieve either Party of any obligations or liabilities for loss or damage to the other Party arising out of, or caused by, acts or omissions of such Party prior to the effectiveness of such termination or arising out of such termination.

11.7.2 All obligations surviving the cancellation, expiration or termination of this Agreement shall only survive for a period of 3 (three) years following the date of such termination or expiry of this Agreement.

11.8 Severability

If for any reason whatever any provision of this Agreement is or becomes invalid, illegal or unenforceable or is declared by any court of competent jurisdiction or any other instrumentality to be invalid, illegal or unenforceable, the validity, legality or enforceability of the remaining provisions shall not be affected in any manner, and the Parties will negotiate in good faith with a view to agreeing to one or more provisions which may be substituted for such invalid, unenforceable or illegal provisions, as nearly as is practicable to such invalid, illegal or unenforceable provision. Failure to agree upon any such provisions shall not be subject to dispute resolution under Clause 10.1 of this Agreement or otherwise.

11.9 Successors and assigns

This Agreement shall be binding on and shall inure to the benefit of the Parties and their respective successors and permitted assigns.

11.10 Notices

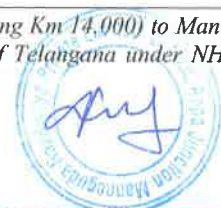

All notices or other communications to be given or made under this Agreement shall be in writing and shall either be delivered personally or sent by courier or registered post with an additional copy to be sent by facsimile or e-mail. The address for service of each Party, its facsimile number and e-mail are set out under its name on the signing pages hereto. A notice shall be effective upon actual receipt thereof, save that where it is received after 5.30 (five thirty) p.m. on a business day, or on a day that is not a business day, the notice shall be deemed to be received on the first business day following the date of actual receipt. Without prejudice to the foregoing, a Party giving or making a notice or communication by facsimile or e-mail shall promptly deliver a copy thereof personally, or send it by courier or registered post to the addressee of such notice or communication. It is hereby agreed and acknowledged that any Party may by notice change the address to which such notices and communications to it are to be delivered or mailed. Such change shall be effective when all the Parties have notice of it.

11.11 Language

All notices, certificates, correspondence and proceedings under or in connection with this Agreement shall be in English.

11.12 Authorized representatives

Each of the Parties shall, by notice in writing, designate their respective authorized representatives through whom only all communications shall be made. A Party hereto shall be entitled to remove and/or substitute or make fresh appointment of such authorized representative by similar notice.

11.13 Original Document

This Agreement may be executed in four counterparts, each of which when executed and delivered shall constitute an original of this Agreement.

IN WITNESS WHEREOF THE PARTIES HAVE EXECUTED AND DELIVERED THIS AGREEMENT AS OF THE DATE FIRST ABOVE WRITTEN.

THE COMMON SEAL OF CONCESSIONAIRE has been affixed pursuant to the resolution passed by the by the Board of Directors of the Concessionaire at its meeting held on the ___ day of 20__ hereunto affixed in the presence of, Director, who has signed these presents in token thereof and Company Secretary / Authorized Officer who has countersigned the

SIGNED, SEALED
AND DELIVERED
For and on behalf of
SENIOR LENDERS by the
Lender's Representative:

273



same in token thereof[¶]

(Signature)

(Signature)

(Name)

(Name)

(Designation)

(Designation)

(Address)

(Address)

(Fax No.)

(Fax No.)

(E-Mail Address)

(E-Mail Address)

SIGNED, SEALED AND
DELIVERED

SIGNED, SEALED AND
DELIVERED

For and on behalf of

For and on behalf of

ESCROW BANK by:

THE AUTHORITY by:

(Signature)

(Signature)

(Name)

(Name)

(Designation)

(Designation)

(Address)

(Address)

(Fax No.)

(Fax No.)

(E-Mail Address)

(E-Mail Address)

SIGNED, SEALED

In the presence of

1.

2.

[¶]To be affixed in accordance with the articles of association of the Concessionaire and the resolution passed by its Board of Directors.

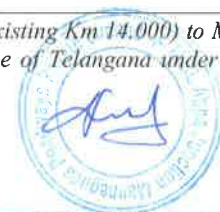

SCHEDULE - P

(See Clause 27.2.1)

PANEL OF CHARTERED ACCOUNTANTS

1 Panel of Chartered Accountants

Pursuant to the provisions of Clause 27.2.1 of the Agreement, the Authority and the Concessionaire shall prepare a mutually agreed panel of 5 (five) reputable firms of Chartered Accountants having their registered offices in India (the "Panel of Chartered Accountants"). The criteria for preparing such Panel and the procedure to be adopted in this behalf shall be as set forth in this Schedule-P.

2 Invitation for empanelment

2.1 The Authority shall invite offers from all reputed firms of Chartered Accountants who fulfil the following eligibility criteria, namely:

- (a) the firm should have conducted statutory audit of the annual accounts of at least one hundred companies registered under the Companies Act, 1956, including any re-enactment or amendment thereof, of which at least ten should have been public sector undertakings;
- (b) The firm should have at least 5 (five) practicing Chartered Accountants on its rolls, each with a minimum experience of ten years in the profession;
- (c) The firm or any of its partners should not have been disqualified or black-listed by the Comptroller and Auditor General of India or the Authority; and
- (d) The firm should have an office in the State or in an adjacent State with at least 2 (two) practicing Chartered Accountants on its rolls in such State.

2.2 Interested firms meeting the eligibility criteria shall be required to submit a statement of their capability including the bio-data of all the practicing Chartered Accountants on its rolls. In particular, each firm shall be required to furnish year-wise information relating to the names of all the companies with an annual turnover exceeding Rs. 25,00,00,000 (Rs. twenty five crore) whose annual accounts were audited by such firm in any of the preceding 5 (five) Accounting Years

3 Evaluation and selection

3.1 The information furnished by each firm shall be scrutinized and evaluated by the Authority and 1 (one) point shall be awarded for each annual audit of the companies specified in Paragraph 2.2 above. (For the avoidance of doubt and by way of illustration, a firm which has conducted audit of the annual accounts of any such company for 5 (five) years shall be awarded 5 (five) points).

3.2 The Authority shall prepare a list of all the eligible firms along with the points scored by each such firm and 5 (five) firms scoring the highest points shall be identified and included in the draft Panel of Chartered Accountants.



4 Consultation with the Concessionaire

The Authority shall convey the aforesaid panel of firms to the Concessionaire for scrutiny and comments, if any. The Concessionaire shall be entitled to scrutinize the relevant records of the Authority to ascertain whether the selection of firms has been undertaken in accordance with the prescribed procedure and it shall send its comments, if any, to the Authority within 15 (fifteen) days of receiving the aforesaid panel.

5 Mutually agreed panel

- 5.1 The Authority shall, after considering all relevant factors including the comments, if any, of the Concessionaire, finalize and constitute a panel of 5 (five) firms which shall be deemed to be the mutually agreed Panel of Chartered Accountants.
- 5.2 After completion of every 5 (five) years from the date of preparing the mutually agreed Panel of Chartered Accountants, or such earlier period as may be agreed between the Authority and the Concessionaire, a new panel shall be prepared in accordance with the provisions of this Schedule-P.



SCHEDULE - Q

(See Clause 32.4)

VESTING CERTIFICATE

- 1 The Chairman, National Highways Authority of India (the "Authority") refers to the Concession Agreement dated (the "Agreement") entered into between the Authority and (the "Concessionaire") for **Four laning of NH-163 from Hyderabad (ORR Appa Junction) (Design Km 14.000/Existing Km 14.000) to Manneguda (Design Km 60.405/Existing Km 59.500) (Design Length = 46.405 Km) in the State of Telangana under NH(O) (the "Project Highway")** on design, build, operate and transfer ("DBOT Annuity or Hybrid Annuity") basis.
- 2 The Authority hereby acknowledges compliance and fulfilment by the Concessionaire of the Divestment Requirements set forth in Clause 32.1 of the Agreement on the basis that upon issue of this Vesting Certificate, the Authority shall be deemed to have acquired, and all title and interest of the Concessionaire in or about the Project shall be deemed to have vested unto the Authority, free from any encumbrances, charges and liens whatsoever.
- 3 Notwithstanding anything to the contrary contained hereinabove, it shall be a condition of this Vesting Certificate that nothing contained herein shall be construed or interpreted as waiving the obligation of the Concessionaire to rectify and remedy any defect or deficiency in any of the Divestment Requirements and/or relieving the Concessionaire in any manner of the same.

Signed this..... day of....., 20..... At.....

AGREED, ACCEPTED AND SIGNED

SIGNED, SEALED AND DELIVERED

For and on behalf of

for and on behalf of

CONCESSIONAIRE by:

AUTHORITY by:

(Signature)

(Signature)

(Name)

(Name)

(Designation)

(Designation)

(Address)

(Address)

In the presence of:

1.

2.

277



SCHEDULE - R

(See Clause 34.3.1)

SUBSTITUTION AGREEMENT

THIS SUBSTITUTION AGREEMENT is entered into on this the.....day of.....20.....

AMONGST

- 1 The NATIONAL HIGHWAYS AUTHORITY OF INDIA, established under the National Highways Authority of India Act 1988, represented by its Chairman and having its principal offices at G-5 & 6, Sector – 10, Dwarka, New Delhi - 110075 (Hereinafter referred to as the "Authority" which expression shall unless repugnant to the context or meaning thereof include its administrators, successors and assigns);
- 2Limited, a company incorporated under the provisions of the Companies Act, 2013 and having its registered office at (Hereinafter referred to as the "**Concessionaire**" which expression shall unless repugnant to the context or meaning thereof include its successors and permitted assigns and substitutes);
- 3 (insert name and particulars of Lenders' Representative) and having its registered office at....., acting for and on behalf of the Senior Lenders as their duly authorized agent with regard to matters arising out of or in relation to this Agreement (hereinafter referred to as the "**Lenders' Representative**", which expression shall unless repugnant to the context or meaning thereof include its successors and substitutes);

WHEREAS:

- (A) The Authority has entered into a Concession Agreement dated..... With the Concessionaire (the "**Concession Agreement**") for **Four laning of NH-163 from Hyderabad (ORR Appa Junction) (Design Km 14.000/Existing Km 14.000) to Manneguda (Design Km 60.405/Existing Km 59.500) (Design Length = 46.405 Km) in the State of Telangana under NH(O) Project (the "Project")** on design, build, operate and transfer basis (the "**DBOT Annuity or Hybrid Annuity**"), and a copy of which is annexed hereto and marked as Annex-A to form part of this Agreement.
- (B) Senior Lenders have agreed to finance the Project in accordance with the terms and conditions set forth in the Financing Agreements.
- (C) Senior Lenders have requested the Authority to enter into this Substitution Agreement for securing their interests through assignment, transfer and substitution of the Concession to a Nominated Company in accordance with the provisions of this Agreement and the Concession Agreement.
- (D) In order to enable implementation of the Project including its financing, construction, operation and maintenance, the Authority has agreed and undertaken to transfer and

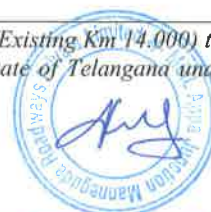

assign the Concession to a Nominated Company in accordance with the terms and conditions set forth in this Agreement and the Concession Agreement.

NOW, THEREFORE, in consideration of the foregoing and the respective covenants and agreements set forth in this Agreement, the receipt and sufficiency of which is hereby acknowledged, and intending to be legally bound hereby, the Parties agree as follows:

1 DEFINITIONS AND INTERPRETATION

1.1 Definitions

In this Substitution Agreement, the following words and expressions shall, unless repugnant to the context or meaning thereof, have the meaning hereinafter respectively assigned to them: **“Agreement”** means this Substitution Agreement and any amendment thereto made in accordance with the provisions contained in this Agreement;

“Financial Default” means occurrence of a material breach of the terms and conditions of the Financing Agreements or a continuous default in Debt Service by the Concessionaire for a minimum period of 3 (three) months;

“Lenders’ Representative” means the person referred to as the Lenders’ Representative in the foregoing Recitals;

“Nominated Company” means a company, incorporated under the provisions of the Companies Act, 1956, including any re-enactment or amendment thereof, selected by the Lenders’ Representative, on behalf of Senior Lenders, and proposed to the Authority for assignment/transfer of the Concession as provided in this Agreement;

“Notice of Financial Default” shall have the meaning ascribed thereto in Clause 3.2.1; and

“Parties” means the parties to this Agreement collectively and **“Party”** shall mean any of the Parties to this Agreement individually.

1.2 Interpretation

1.2.1 References to Lenders’ Representative shall, unless repugnant to the context or meaning thereof, mean references to the Lenders’ Representative, acting for and on behalf of Senior Lenders.

1.2.2 References to Clauses are, unless stated otherwise, references to Clauses of this Agreement.

1.2.3 The words and expressions beginning with capital letters and defined in this Agreement shall have the meaning ascribed thereto herein, and the words and expressions used in this Agreement and not defined herein but defined in the Concession Agreement shall, unless repugnant to the context, have the meaning ascribed thereto in the Concession Agreement.

1.2.4 The rules of interpretation stated in Clauses 1.2, 1.3 and 1.4 of the Concession Agreement shall apply, mutatis mutandis, to this Agreement.



2 ASSIGNMENT

2.1 Assignment of rights and title

The Concessionaire hereby agrees to assign the rights, title and interest in the Concession to, and in favor of, the Lenders' Representative pursuant to and in accordance with the provisions of this Agreement and the Concession Agreement by way of security in respect of financing by the Senior Lenders under the Financing Agreements.

3 SUBSTITUTION OF THE CONCESSIONAIRE

3.1 Rights of substitution

3.1.1 Pursuant to the rights, title and interest assigned under Clause 2.1, the Lenders' Representative shall be entitled to substitute the Concessionaire by a Nominated Company under and in accordance with the provisions of this Agreement and the Concession Agreement.

3.1.2 The Authority hereby agrees to substitute the Concessionaire by endorsement on the Concession Agreement in favor of the Nominated Company selected by the Lenders' Representative in accordance with this Agreement. For the avoidance of doubt, the Senior Lenders or the Lenders' Representative shall not be entitled to operate and maintain the Project as Concessionaire either individually or collectively.

3.2 Substitution upon occurrence of Financial Default

3.2.1 Upon occurrence of a Financial Default, the Lenders' Representative may issue a notice to the Concessionaire (the "Notice of Financial Default") along with particulars thereof, and send a copy to the Authority for its information and record. A Notice of Financial Default under this Clause 3 shall be conclusive evidence of such Financial Default and it shall be final and binding upon the Concessionaire for the purposes of this Agreement.

3.2.2 Upon issue of a Notice of Financial Default hereunder, the Lenders' Representative may, without prejudice to any of its rights or remedies under this Agreement or the Financing Agreements, substitute the Concessionaire by a Nominated Company in accordance with the provisions of this Agreement.

3.2.3 At any time after the Lenders' Representative has issued a Notice of Financial Default, it may by notice require the Authority to suspend all the rights of the Concessionaire and undertake the operation and maintenance of the Project in accordance with the provisions of Article 30 of the Concession Agreement, and upon receipt of such notice, the Authority shall undertake Suspension under and in accordance with the provisions of the Concession Agreement. The aforesaid Suspension shall be revoked upon substitution of the Concessionaire by a Nominated Company, and in the event such substitution is not completed within 180 (one hundred and eighty) days from the date of such Suspension, the Authority may terminate the Concession Agreement forthwith by issuing a Termination Notice in accordance with the provisions of the Concession Agreement; provided that upon written request from the Lenders' Representative and the Concessionaire, the Authority may extend the aforesaid period of 180 (one hundred



and eighty) days by a period not exceeding 90 (ninety) days. For the avoidance of doubt, the Authority expressly agrees and undertakes to terminate the Concession Agreement forthwith, upon receipt of a written request from the Lenders' Representative at any time after 240 (two hundred and forty) days from the date of Suspension hereunder.

3.3 Substitution upon occurrence of Concessionaire Default

3.3.1 Upon occurrence of a Concessionaire Default, the Authority shall by a notice inform the Lenders' Representative of its intention to issue a Termination Notice and grant 15 (fifteen) days' time to the Lenders' Representative to make a representation, stating the intention to substitute the Concessionaire by a Nominated Company.

3.3.2 In the event that the Lenders' Representative makes a representation to the Authority within the period of 15 (fifteen) days specified in Clause 3.3.1, stating that it intends to substitute the Concessionaire by a Nominated Company, the Lenders' Representative shall be entitled to undertake and complete the substitution of the Concessionaire by a Nominated Company in accordance with the provisions of this Agreement within a period of 180 (one hundred and eighty) days from the date of such representation, and the Authority shall either withhold Termination or undertake Suspension for the aforesaid period of 180 (one hundred and eighty) days; provided that upon written request from the Lenders' Representative and the Concessionaire, the Authority shall extend the aforesaid period of 180 (one hundred and eighty) days by a period not exceeding 90 (ninety) days; provided further that the Lenders' Representative may at any time withdraw its representation hereunder and upon such withdrawal, the Authority may terminate this Agreement in accordance with the provisions hereof.

3.4 Procedure for substitution

3.4.1 The Authority and the Concessionaire hereby agree that on or after the date of Notice of Financial Default or the date of representation to the Authority under Clause 3.3.2, as the case may be, the Lenders' Representative may, without prejudice to any of the other rights or remedies of the Senior Lenders, invite, negotiate and procure offers, either by private negotiations or public auction or tenders for the take over and transfer of the Project including the Concession to the Nominated Company upon such Nominated Company's assumption of the liabilities and obligations of the Concessionaire towards the Authority under the Concession Agreement and towards the Senior Lenders under the Financing Agreements.

3.4.2 To be eligible for substitution in place of the Concessionaire, the Nominated Company shall be required to fulfil the eligibility criteria that were laid down by the Authority for short listing the bidders for award of the Concession; provided that the Lenders' Representative may represent to the Authority that all or any of such criteria may be waived in the interest of the Project, and if the Authority determines that such waiver shall not have any material adverse effect on the Project, it may waive all or any of such eligibility criteria.

3.4.3 Upon selection of a Nominated Company, the Lenders' Representative shall request the Authority to:



- (a) Accede to transfer to the Nominated Company the right to construct, operate and maintain the Project in accordance with the provisions of the Concession Agreement;
- (b) Endorse and transfer the Concession to the Nominated Company, on the same terms and conditions, for the residual Concession Period; and
- (c) Enter into a Substitution Agreement with the Lenders' Representative and the Nominated Company on the same terms as are contained in this Agreement.

3.4.4 If the Authority has any objection to the transfer of Concession in favor of the Nominated Company in accordance with this Agreement, it shall within 15 (fifteen) days from the date of proposal made by the Lenders' Representative, give a reasoned order after hearing the Lenders' Representative. If no such objection is raised by the Authority, the Nominated Company shall be deemed to have been accepted. The Authority shall thereupon transfer and endorse the Concession within 15 (fifteen) days of its acceptance/deemed acceptance of the Nominated Company; provided that in the event of such objection by the Authority, the Lenders' Representative may propose another Nominated Company whereupon the procedure set forth in this Clause 3.4 shall be followed for substitution of such Nominated Company in place of the Concessionaire.

3.4.5 The transfer of Concession hereunder to a Nominated Company may, notwithstanding anything to the contrary in this Agreement and the Concession Agreement, be undertaken by transfer of no less than 75% (seventy five per cent) of the equity of the Concessionaire to the Nominated Company, and upon such transfer hereunder, the Concessionaire shall be deemed to be the Nominated Company under and in accordance with the provisions of this Agreement and the Concession Agreement.

3.5 Selection to be binding

The decision of the Lenders' Representative and the Authority in selection of the Nominated Company shall be final and binding on the Concessionaire. The Concessionaire irrevocably agrees and waives any right to challenge the actions of the Lenders' Representative or the Senior Lenders or the Authority taken pursuant to this Agreement including the transfer/assignment of the Concession in favor of the Nominated Company. The Concessionaire agrees and confirms that it shall not have any right to seek revaluation of assets of the Project or the Concessionaire's shares. It is hereby acknowledged by the Parties that the rights of the Lenders' Representative are irrevocable and shall not be contested in any proceedings before any court or Authority and the Concessionaire shall have no right or remedy to prevent, obstruct or restrain the Authority or the Lenders' Representative from effecting or causing the transfer by substitution and endorsement of the Concession as requested by the Lenders' Representative.

4 PROJECT AGREEMENTS

4.1 Substitution of Nominated Company in Project Agreements

The Concessionaire shall ensure and procure that each Project Agreement contains provisions that entitle the Nominated Company to step into such Project Agreement, in



its discretion, in place and substitution of the Concessionaire in the event of such Nominated Company's assumption of the liabilities and obligations of the Concessionaire under the Concession Agreement.

5 TERMINATION OF CONCESSION AGREEMENT

5.1 Termination upon occurrence of Financial Default

At any time after issue of a Notice of Financial Default, the Lenders' Representative may by a notice in writing require the Authority to terminate the Concession Agreement forthwith, and upon receipt of such notice, the Authority shall undertake Termination under and in accordance with the provisions of Article 31 of the Concession Agreement.

5.2 Termination when no Nominated Company is selected

In the event that no Nominated Company acceptable to the Authority is selected and recommended by the Lenders' Representative within the period of 180 (one hundred and eighty) days or any extension thereof as set forth in Clause 3.3.2, the Authority may terminate the Concession Agreement forthwith in accordance with the provisions thereof.

5.3 Realization of Debt Due

The Authority and the Concessionaire hereby acknowledge and agree that, without prejudice to their any other right or remedy, the Lenders' Representative is entitled to receive from the Concessionaire, without any further reference to or consent of the Concessionaire, the Debt Due upon Termination of the Concession Agreement. For realization of the Debt Due, the Lenders' Representative shall be entitled to make its claim from the Escrow Account in accordance with the provisions of the Concession Agreement and the Escrow Agreement.

6 DURATION OF THE AGREEMENT

6.1 Duration of the Agreement

This Agreement shall come into force from the date hereof and shall expire at the earliest to occur of the following events:

- (a) Termination of the Agreement; or
- (b) No sum remains to be advanced and no sum are outstanding to the Senior Lenders, under the Financing Agreements.

7 INDEMNITY

7.1 General indemnity

- 7.1.1 The Concessionaire will indemnify, defend and hold the Authority and the Lenders' Representative harmless against any and all proceedings, actions and third party claims for any loss, damage, cost and expense of whatever kind and nature arising out of any breach by the Concessionaire of any of its obligations under this Agreement or on



account of failure of the Concessionaire to comply with Applicable Laws and Applicable Permits.

7.1.2 The Authority will indemnify, defend and hold the Concessionaire harmless against any and all proceedings, actions and third party claims for any loss, damage, cost and expense arising out of failure of the Authority to fulfil any of its obligations under this Agreement, materially and adversely affecting the performance of the Concessionaire's obligations under the Concession Agreement or this Agreement, other than any loss, damage, cost and expense, arising out of acts done in discharge of their lawful functions by the Authority, its officers, servants and agents.

7.1.3 The Lenders' Representative will indemnify, defend and hold the Concessionaire harmless against any and all proceedings, actions and third party claims for any loss, damage, cost and expense arising out of failure of the Lenders' Representative to fulfil its obligations under this Agreement, materially and adversely affecting the performance of the Concessionaire's obligations under the Concession Agreement, other than any loss, damage, cost and expense, arising out of acts done in discharge of their lawful functions by the Lenders' Representative, its officers, servants and agents.

7.2 Notice and contest of claims

In the event that any Party hereto receives a claim from a third party in respect of which it is entitled to the benefit of an indemnity under Clause 7.1 or in respect of which it is entitled to reimbursement (the "Indemnified Party"), it shall notify the other Party responsible for indemnifying such claim hereunder (the "Indemnifying Party") within 15 (fifteen) days of receipt of the claim and shall not settle or pay the claim without the prior approval of the Indemnifying Party, such approval not to be unreasonably withheld or delayed. In the event that the Indemnifying Party wishes to contest or dispute the claim, it may conduct the proceedings in the name of the Indemnified Party and shall bear all costs involved in contesting the same. The Indemnified Party shall provide all cooperation and assistance in contesting any claim and shall sign all such writings and documents as the Indemnifying Party may reasonably require.

8 DISPUTE RESOLUTION

8.1 Dispute resolution

8.1.1 Any dispute, difference or claim arising out of or in connection with this Agreement which is not resolved amicably shall be decided by reference to arbitration to a Board of Arbitrators comprising one nominee each of the Authority, Concessionaire and the Lenders' Representative. Such arbitration shall be held in accordance with the Rules of Arbitration of the International Centre for Alternative Dispute Resolution, New Delhi (the "Rules") or such other rules as may be mutually agreed by the Parties, and shall be subject to provisions of the Arbitration and Conciliation Act, 1996.

8.1.2 The Arbitrators shall issue a reasoned award and such award shall be final and binding on the Parties. The place of arbitration shall be the capital of the State and the language of arbitration shall be English.

284



9 MISCELLANEOUS PROVISIONS

9.1 Governing law and jurisdiction

This Agreement shall be construed and interpreted in accordance with and governed by the laws of India, and the courts in the New Delhi shall have jurisdiction over all matters arising out of or relating to this Agreement.

9.2 Waiver of sovereign immunity

The Authority unconditionally and irrevocably:

- (a) agrees that the execution, delivery and performance by it of this Agreement constitute commercial acts done and performed for commercial purpose;
- (b) agrees that, should any proceedings be brought against it or its assets, property or revenues in any jurisdiction in relation to this Agreement or any transaction contemplated by this Agreement, no immunity (whether by reason of sovereignty or otherwise) from such proceedings shall be claimed by or on behalf of the Authority with respect to its assets;
- (c) waives any right of immunity which it or its assets, property or revenues now has, may acquire in the future or which may be attributed to it in any jurisdiction; and
- (d) consents generally in respect of the enforcement of any judgment or award against it in any such proceedings to the giving of any relief or the issue of any process in any jurisdiction in connection with such proceedings (including the making, enforcement or execution against it or in respect of any assets, property or revenues whatsoever irrespective of their use or intended use of any order or judgment that may be made or given in connection therewith).

9.3 Priority of agreements

In the event of any conflict between the Concession Agreement and this Agreement, the provisions contained in the Concession Agreement shall prevail over this Agreement.

9.4 Alteration of terms

All additions, amendments, modifications and variations to this Agreement shall be effectual and binding only if in writing and signed by the duly authorized representatives of the Parties

9.5 Waiver

9.5.1 Waiver by any Party of a default by another Party in the observance and performance of any provision of or obligations under this Agreement:

- (a) Shall not operate or be construed as a waiver of any other or subsequent default hereof or of other provisions of or obligations under this Agreement;



(b) Shall not be effective unless it is in writing and executed by a duly authorized representative of the Party; and

(c) Shall not affect the validity or enforceability of this Agreement in any manner.

9.5.2 Neither the failure by either Party to insist on any occasion upon the performance of the terms, conditions and provisions of this Agreement or any obligation thereunder nor time or other indulgence granted by a Party to another Party shall be treated or deemed as waiver of such breach or acceptance of any variation or the relinquishment of any such right hereunder.

9.6 No third party beneficiaries

This Agreement is solely for the benefit of the Parties and no other person or entity shall have any rights hereunder.

9.7 Survival

9.7.1 Termination of this Agreement:

(a) Shall not relieve the Parties of any obligations hereunder which expressly or by implication survive termination hereof; and

(b) except as otherwise provided in any provision of this Agreement expressly limiting the liability of either Party, shall not relieve either Party of any obligations or liabilities for loss or damage to the other Party arising out of or caused by acts or omissions of such Party prior to the effectiveness of such termination or arising out of such termination.

9.7.2 All obligations surviving the cancellation, expiration or termination of this Agreement shall only survive for a period of 3 (three) years following the date of such termination or expiry of this Agreement.

9.8 Severability

If for any reason whatever any provision of this Agreement is or becomes invalid, illegal or unenforceable or is declared by any court of competent jurisdiction or any other instrumentality to be invalid, illegal or unenforceable, the validity, legality or enforceability of the remaining provisions shall not be affected in any manner, and the Parties will negotiate in good faith with a view to agreeing to one or more provisions which may be substituted for such invalid, unenforceable or illegal provisions, as nearly as is practicable to such invalid, illegal or unenforceable provision. Failure to agree upon any such provisions shall not be subject to dispute resolution under Clause 8 of this Agreement or otherwise.

9.9 Successors and assigns

This Agreement shall be binding on and shall inure to the benefit of the Parties and their respective successors and permitted assigns.

9.10 Notices



All notices or other communications to be given or made under this Agreement shall be in writing, shall either be delivered personally or sent by courier or registered post with an additional copy to be sent by facsimile or e-mail. The address for service of each Party, its facsimile number and e-mail address are set out under its name on the signing pages hereto. A notice shall be effective upon actual receipt thereof, save that where it is received after 5.30 (five thirty) p.m. on any day, or on a day that is a public holiday, the notice shall be deemed to be received on the first working day following the date of actual receipt. Without prejudice to the foregoing, a Party giving or making a notice or communication by facsimile or e-mail shall promptly deliver a copy thereof personally, or send it by courier or registered post to the addressee of such notice or communication. It is hereby agreed and acknowledged that any Party may by notice change the address to which such notices and communications to it are to be delivered or mailed. Such change shall be effective when all the Parties have notice of it.

9.11 Language

All notices, certificates, correspondence and proceedings under or in connection with this Agreement shall be in English.

9.12 Authorized representatives

Each of the Parties shall by notice in writing designate their respective authorized representatives through whom only all communications shall be made. A Party hereto shall be entitled to remove and/or substitute or make fresh appointment of such authorized representative by similar notice.

9.13 Original Document

This Agreement may be executed in three counterparts, each of which when executed and delivered shall constitute an original of this Agreement.

IN WITNESS WHEREOF THE PARTIES HAVE EXECUTED AND DELIVERED THIS AGREEMENT AS OF THE DATE FIRST ABOVE WRITTEN

THE COMMON SEAL OF CONCESSIONAIRE has SIGNED, SEALED AND DELIVERED For and behalf of THE AUTHORITY by:
been affixed pursuant to the resolution passed by the Board of Directors of the Concessionaire at its meeting held on the.....day of the20.....here unto affixed in to the presence of.....the Director, who has signed these presents in token thereof,Company Secretary /Authorized Officer who has countersigned the same in token thereof⁴.

287

⁴To be affixed in accordance with the articles of association of the Concessionaire and the resolution passed by its Board of Directors Four laning of NH-163 from Hyderabad (ORR Appa Junction) (Design Km 14.000/Existing Km 14.000) to Manneguda (Design Km 60.405/Existing Km 59.500) (Design Length = 46.405 Km) in the State of Telangana under NH(O) on Hybrid Annuity ModePage 220

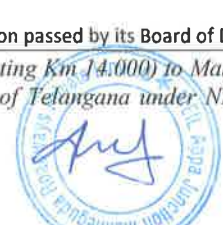

SCHEDULE – S

Procedure for Dispute Resolution Board

The parties to the Concession Agreement mutually agree as follows:

- (1) The Board shall comprise of three Members having experience in the field of construction or have been involved in the Works related to construction and with the interpretation of contractual documents. One Member shall be selected by each of the Authority and the Concessionaire from the list maintained by NHAI hosted on its website (www.nhai.gov.in). In the event the parties fail to select the member within 28 days of the date of the signing of Concession Agreement, in that eventuality, upon the request of either or both parties such Member shall be selected by SAROD within 14 days. The third Member shall be selected by the other two members from the same list. If the two Members selected by or on behalf of the parties fail to select the third Member within 14 days after the later of their selections, then upon the request of either or both parties such third Member shall be selected by SAROD within 14 days. The third Member shall serve as Chairman of the Board
- (2) The Board shall be constituted when each of the three Board Members has signed a Board Member's declaration of Acceptance as required by the DRB's rules and procedures (which, along with the declaration of acceptance form, are attached as Annexure herewith).
- (3) In the event of death, disability, or resignation of any Member, such Member shall be replaced in the same manner as the Member being replaced was selected. If for any other reason, a Member fails or is unable to serve, the Chairman (or failing the action of the Chairman then either of the other Members) shall inform the Parties and such non-serving Member shall be replaced in the same manner as the Member being replaced was selected. Any replacement made by the parties shall be completed within 28 days after the event giving rise to the vacancy on the Board, failing which the replacement shall be made by SAROD in the same manner as described above. Replacement shall be considered complete when the new Member signs the Board Member's Declaration of Acceptance. Throughout any replacement process, the Members not being replaced shall continue to serve and the Board shall continue to function and its activities shall have the same force and effect as if the vacancy had not occurred, provided, however, that the Board shall not conduct a hearing nor issue a decision until the replacement is completed
- (4) If either the Authority or the Concessionaire is dissatisfied with any decision of the Board, and/or if the Board fails to issue its decision within 56 days after receipt of all the pleadings (along with the supporting documents) of the parties by the Chairman of the Board or any extension mutually agreed upon by the Authority and the Concessionaire, in such a case, either the Authority or the Concessionaire may, within 28 days after his receipt of the decision, or within 28 days after the expiry of the said period, as the case may be, give notice to the other party, with a copy for information to the Independent Engineer, of his intention to refer the matter to the Conciliation Committee of Independent Experts (CCIE) of the Authority for Conciliation/amicable settlement.
- (5) It is mandatory to refer all the disputes to DRB before issuance of completion certificate and satisfactory completion of punch list items. No dispute shall be entertained after completion of aforementioned date.



- (6) If the Board has issued a decision to the Authority and the Concessionaire within the said 56 days or any extension mutually agreed upon by the Authority and the Concessionaire and no notice of intention to commence Conciliation by the Conciliation Committee of Independent Experts (CCIE) of the Authority for Conciliation/amicable settlement as to such dispute has been given by either the Authority or the Concessionaire within 28 days after the parties received such decision from the Board, the decision shall become final and binding upon the Authority and Concessionaire.
- (7) Whether or not it has become final and binding upon the Authority and the Concessionaire, a decision shall be admissible as evidence in any subsequent dispute resolution procedure, including any arbitration or litigation having any relation to the dispute to which the decision relates.
- (8) All decision of DRB which have become final and binding or till they have been reversed in subsequent conciliation/Arbitration process shall be implemented by the parties forthwith. Such implementation shall also include any relevant action of the Independent Engineer
- (9) If during the Concession Period, the Authority and the Concessionaire are of the opinion that the Disputes Resolution Board is not performing its functions properly, the Authority and the Concessionaire may together disband the Disputes Resolution Board and reconstitute it. In that case, a new board shall be selected in accordance with the provisions applying to the selection of the original Board as specified above, except that words "within 28 days after the signing of this Concession Agreement" shall be replaced by the words "within 28 days after the date on which the notice disbanding the original Board became effective
- (10) The Authority and the Concessionaire shall jointly sign a notice specifying that the Board shall stand disbanded with effect from the date specified in the notice. The notice shall be posted by email to each Member of the Board. A Member shall be deemed to have received the e mail even if he refuses to have received the same.
- (11) All other terms and conditions of the original Concession Agreement shall remain unaltered/unaffected and the parties shall remain bound by terms and conditions as contained therein.



Annexure to Schedule-S

Disputes Resolution Board's Rules and Procedures

1. Except for providing the services required hereunder, the Board Members shall not give any advice to either party or to the Independent Engineer concerning conduct of the Works. The Board Members:
 - (a). Shall have no financial interest in any party to the Concession Agreement, or the Independent Engineer, or a financial interest in the Concession, except for payment for services on the Board.
 - (b). Shall have had no previous employment by, or financial ties to, any party to the Concession Agreement, or the Independent Engineer, except for fee based consulting services/advisers on other projects, and/or be Retired Government Officers (not connected in whole or part with the project), all of which must be disclosed in writing to both parties prior to appointment to the Board.
 - (c). Shall have disclosed in writing to both parties prior to appointment to the Board any and all recent or close professional or personal relationships with any director, officer, or employee of any party to the Concession Agreement, or the Independent Engineer, and any and all prior involvement in the project to which the Concession relates;
 - (d). Shall not, while Board member, be employed whether as a consultant or adviser or otherwise by either party to the Concession Agreement, or the Independent Engineer, except as a Board Member, without the prior consent of the parties and the other Board Members,
 - (e). Shall not, while a Board Member, engage in discussion or make any agreement with any party to the Concession Agreement, or with the Independent Engineer, regarding employment whether as a consultant or otherwise whether after the Concession is completed or after service as a Board Member is completed
 - (f). Shall remain and be impartial and independent of the parties and shall disclose in writing to the Authority, the Concessionaire and one another any fact or circumstance which might be such as to cause either the Authority or the Concessionaire to question the continued existence of the impartiality and independence required of Board Members; and
 - (g). Shall be fluent in the language of the Concession.
2. Except for its participation in the Board's activities as provided in the Concession and in this Agreement none of the Authority, the Concessionaire, and or the Independent Engineer shall solicit advice or consultation from the Board or the Board Members on matters dealing with the conduct of the Works.
3. The Concessionaire shall:



PUBLIC PRIVATE PARTNERSHIP IN HYBRID ANNUITY PROJECTS

- (a). Furnish to each Board member one copy of all documents which the Board may request including Concession Agreement, progress reports and other documents pertinent to the performance of the Concession Agreement.
 - (b). In cooperation with the Authority, coordinate the site visits of the Board, including conference facilities, and secretarial and copying service.
4. The Board shall begin its activities following the signing of a Board Member's Declaration of Acceptance by all three Board Members, and it shall terminate these activities as set forth below:
 - (a). The Board shall terminate its regular activities when either (i) issuance of completion certificate and completion of punch list items or (ii) the parties have terminated the Concession and when, in either case, the Board has communicated to the parties and the Independent Engineer its decision on all disputes previously referred to it.
 - (b). Once the Board has terminated its regular activities as provided by the previous paragraph, the Board shall remain available to process any dispute referred to it by either party. In case of such a referral, Board Members shall receive payments as provided in paragraphs 7(a) (ii), (iii) and (iv).
5. Board Members shall not assign or subcontract any of their work under these Rules and Procedures.
6. The Board Members are Independent and not employees or agents of either the Authority or the Concessionaire.
7. Payments to the Board Members for their services shall be governed by the following provisions:
 - (a). Each Board Member will receive payments as follows:
 - i. A retainer fee per calendar month as specified in the schedule of fee made part of this Schedule and its revision from time to time. This retainer fee shall be considered as payment in full for:
 - (A). Being available, on 7 days' notice, for all hearings, Site Visits, and other meetings of the Board.
 - (B). Being conversant with all project developments and maintaining relevant files.
 - (C). All offices and overhead expenses such as secretarial services, photocopying and office supplies (but not include telephone calls, faxes and telexes) incurred in connection with the duties as a Board Member
 - ii. A daily fee as specified in the schedule of fee in respect of fee for site visit & meeting, fee for meeting/ hearing not at site and extra charges for days (max. of 02 days for travel on each occasion) other than hearing/meeting days.

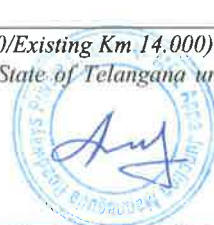

- iii. Expenses, in addition to the above, all reasonable and necessary travel expenses (including economy class air fare, subsistence, and other direct travel expenses) Receipts for all expenses in excess of Rs. 2000/- (Rupees Two Thousand only) shall be provided.
- iv. Reimbursement of any taxes that may be levied on payments made to the Board Member pursuant to this paragraph 7.

(b). The retainer fee and other fees shall remain fixed for the period of each Board Member's term until revised by NHAI.

(c). Phasing out of monthly retainer fee. Beginning with the next month after the completion certificate (or, if there are more than one, the one issued last) has been issued, the Board members shall receive only one-third of the monthly retainer fee till next one year. Beginning with the next month after the Board has terminated its regular activities pursuant to paragraph 4(a) above, the Board members shall no longer receive any monthly retainer fee.

(d). Payments to the Board Members shall be shared equally by the Authority and the Concessionaire. The concerned Project Implementation Unit (PIU) of Authority shall pay members' invoices within 30 calendar days after receipt of such invoices and shall invoice the Concessionaire for one-half of the amounts of such invoices. The Concessionaire shall pay such invoices within 30 days' time period after receipt of such invoices.

8. Board Site Visits:

(a). The Board shall visit the Site and meet the representatives of the Authority, the Concessionaire and the Independent Engineer at regular intervals, at times of critical construction events, at the written request of either party, and in any case not less than 6 times in any period of 12 months. The timing of Site visits shall be as agreed among the Authority, the Concessionaire and the Board, but failing agreement shall be fixed by the Board.

(b). Site visits shall include an informal discussion of the status of the construction of the Works. Site visits shall be attended by personnel from the Authority, the Concessionaire and the Independent Engineer

(c). At the conclusion of each Site visit, the Board shall prepare a report covering its activities during the visit and shall send copies to the parties and to the Independent Engineer.

9. Procedure for Dispute Referral to the Board:

(a) If either party objects to any action or inaction of the other party or the Independent Engineer, the objecting party may file a written Notice of Dispute to the other party with a copy to the Independent Engineer stating that it is given pursuant to the Agreement and state clearly and in details the basis of the dispute.

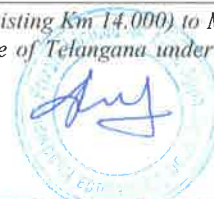

PUBLIC PRIVATE PARTNERSHIP IN HYBRID ANNUITY PROJECTS

(b) The party receiving the Notice of Dispute will consider it and respond to it in writing within 14 days after receipt.

(c) This response shall be final and conclusive on the subject, unless a written appeal to the response is filed with the responding party within 10 days after receiving the response and call upon Independent Engineer to mediate and assist the parties in arriving an amicable settlement thereof. Both parties are encouraged to pursue the matter further to attempt to settle the dispute.

(d) If the Independent Engineer receiving the Notice of Dispute fails to provide a written response within 14 days after receipt of such Notice or failing mediation by Independent Engineer, either party may require such dispute to be referred to the Board, either party may refer the dispute to the Board by written Request to the Board. The Request for decision shall state clearly and in full detail the specific issues of the dispute (s) to be considered by Board and shall be addressed to the Chairman of the Board, with copies to the other Board Members, the other party, and the Independent Engineer, and it shall state that it is made pursuant to this Agreement.

(e) When a dispute is referred to the Board, and the Board is satisfied that the dispute requires the Board's assistance, the Board decide when to conduct a hearing on the dispute. The Board may request that written documentation and arguments from both parties be submitted to each Board Member before the hearing begins. The parties shall submit insofar as possible agreed statements of the relevant facts.

(f) During the hearing, the Concessionaire, the Authority, and the Independent Engineer shall each have ample opportunity to be heard and to offer evidence. The Board's decision for resolution of the dispute will be given in writing to the Authority, the Concessionaire and the Independent Engineer as soon as possible, and in any event not more than 56 days or any mutually extended period between the Authority and the Concessionaire. The time period of 56 days of issuance of DRB decision will reckon/start from the day of first hearing that begins after submission of complete pleadings (including supporting documents, if any) by the parties.

10. Conduct of Hearings:

(a) Normally hearings will be conducted at the Site, but any location that would be more convenient and still provide all required facilities and access to necessary documentation may be utilized by the Board. Private session of the Board may be held at any cost effective location convenient to the Board. Video recordings of all hearings shall invariably be made.

(b) The Authority, the Independent Engineer and the Concessionaire shall be given opportunity to have representatives at all hearings. Parties should restrain to bring any Advocate/Law Firm during DRB hearings.

(c) During the hearings, no Board Member shall express any opinion concerning the merit of the respective arguments of the parties.

(d) After the hearings are concluded, the Board shall meet privately to formulate its decision. The private meeting (s) of the Board shall not exceed 3 sittings. All Board deliberations shall be conducted in private, with all Members' individual views kept strictly confidential. The Board's decisions, together with an explanation of its reasoning shall be submitted in writing to both

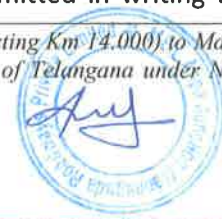

parties and to the Independent Engineer. The decision shall be based on the pertinent Concession provisions, applicable laws and regulations and the facts and circumstances involved in the dispute.

(e) The Board shall make every effort to reach a unanimous decision. If this proves impossible the majority shall decide and the dissenting Member may prepare a written minority report together with an explanation of its reasoning for submission to both parties and to the Independent Engineer.

11. In all procedural matters, including the furnishing of written documents and arguments relating to disputes, site visits and conduct of hearings, the Board shall have full and the final authority. If a unanimous decision on any such matter proves impossible, the majority shall prevail.

12. After having been selected and where necessary approved each Board Member shall sign two copies of the following declaration and make one copy available each to the Authority and to the Concessionaire.



“BOARD MEMBER’S DECLARATION OF ACCEPTANCE”

WHEREAS

- (a). A Concession Agreement (the **Concession**) for the _____ project [fill in the name of project] has been signed on _____ [fill in date] between _____ [name of Authority] and _____ [name of Concessionaire] (the Concessionaire).;
- (b). The provisions of Agreement and Dispute Resolution Board’s rules and procedure provided for establishment and operation of Dispute Resolution Board (DRB).
- (c). The undersigned has been selected to serve as a Board Member on said Board;

NOW THEREFORE, the undersigned Board Member hereby declares as follows:

1. I accept the selection as a Board Member and agree to serve on the Board and to be bound by the provisions of Concession Agreement and rules and procedure provided for establishment and operation of Dispute Resolution Board (DRB).
2. With respect to paragraph 1 of Dispute Resolution Board’s Rules and Procedure. said Annex A, I declare
 - (a). that I have no financial interest of the kind referred to in subparagraph (a):
 - (b). that I have had no previous employment nor financial ties of the kind referred to in subparagraph (b); and
 - (c). that I have made to both parties any disclosures that may be required by subparagraphs (b) and (c).
3. I declare that I have ___ no. of Arbitrations (list enclosed) and no. of DRBs (list enclosed) in progress and that I will give sufficient time for the current assignment.

BOARD MEMBER

_____ (insert name of Board Member)

Date: _____



**Schedule of expenses and fees payable to the
Member (s) of Dispute Resolution Board (DRB)**

The fee and other expenses payable to the Members of DRB shall be as under:-

S. No.	PARTICULAR	AMOUNT PAYABLE
1.	Retainer-ship fee, secretarial assistance and incidental charges (telephone, fax, postage etc.)	Rs. 50,000/- per month for one package and maximum of Rs. 75,000/- per month for 2 or more packages
2. (i)	Fee for site visit or meetings at site	Rs. 25,000/- per day
(ii)	Fee for meetings/hearings not at site	Rs. 10,000/- per day
3.	Traveling expenses	Economy class by air, AC first class by train and AC taxi by road
4.	Lodging & Boarding	Rs. 15,000/- per day (Metro Cities); or Rs. 10,000/- per day (in other cities); or Rs. 5,000/- per day (own arrangement)
5.	Extra charges for days other than hearing/meeting days (travel days maximum of 2 days on each occasion)	Rs. 5,000/-
6.	Local conveyance	Rs. 2,000/-

Notes:

- (i) Lodging, boarding and travelling expenses will be allowed only for those members who are residing 100 kms away from the place of meeting.
- (ii) Delhi, Mumbai, Chennai, Kolkata, Bangalore and Hyderabad shall be considered as Metro Cities.
- (iii) The above schedule of fee and expenses shall be applicable on or after the date of issue of this circular.
- (iv) The expenses are to be shared equally by the parties i.e. Authority and Concessionaire.

